

Safety relief valve for solar systems



253 series



cert. n° 0003
ISO 9001

01089/06 GB

Replaces 01089/03 GB



General

The safety relief valves manufactured by Caleffi are produced in compliance with the essential safety requirements laid down by Directive 97/23/EC of the European Parliament and the Council of the European Union for the harmonisation of member States with regard to pressurised equipment.

Function

These safety relief valves are used to control pressure in the primary circuits of solar heating systems.

When the calibrated pressure is reached, the valve opens to release the fluid into the atmosphere and prevents the pressure in the system from reaching levels that might damage the solar collectors and equipment installed.

These particular series of products have been specially made and certified to work at high temperature with a glycol medium.



Product range

253 series Safety relief valve for solar systems

size 1/2" F x 3/4" F

Technical specifications

Materials: - body: brass EN 12165 CW 617N, chrome plated
 - control spindle: brass EN 12164 CW614N
 - obturator seal: high resistance elastomer
 - spring: stainless UNI 3823
 - control knob: PA6G30

Medium: water, glycol solutions
 Max. percentage of glycol: 50%

Nominal pressure: PN 10
 Temperature range: -30–160°C

PED category: IV
 Approval: TÜV according to SV 100 7.7
 N° TÜV 01.SOLAR 02.146.p

Connections: 1/2" F x 3/4" F

Performance

Opening overpressure: 10%
 Closing differential: 20%
 Discharge capacity: 50 kW

Code	253043	253044	253046	253048	253040
Set pressure	3 bar	4 bar	6 bar	8 bar	10 bar

Dimensions

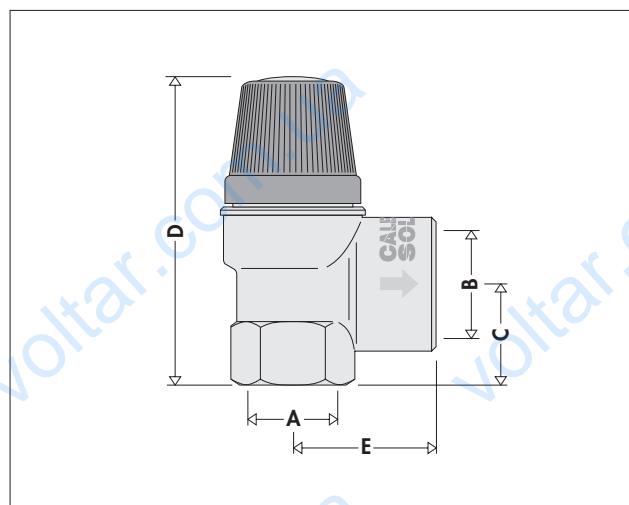

Code	A	B	C	D	E	Weight (kg)
25304.	1/2"	3/4"	24	70	33,5	0,22

Operating principle

The obturator (1), opposed by a set spring (2), raises on reaching the setting pressure and fully opens the outlet. The setting pressure is chosen according to the maximum permissible pressure in the system.

The diameter of the outlet connection (3) is greater in order to help discharge the required potential.

As the pressure decreases there is the opposite action, with the valve subsequently reclosing within the set tolerances.

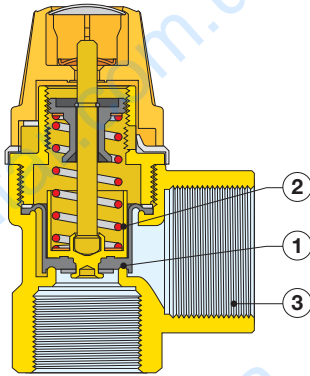

Discharge pipework

The discharge pipework from the safety relief valve must be fitted in such a way as not to prevent the correct operation of the valve and not to cause damage or injury.

In accordance with current legislation, the safety relief valve discharge must be visible and carried in suitable collection pipework. The glycol medium must therefore be drained off into a specific container.

As shown in the diagram, it is advisable to install a tundish directly in the discharge pipework.

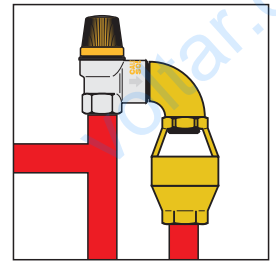

Construction details

Temperature and glycol

In solar systems, heating fluid of the primary circuit contains glycol as additive and operates at high temperatures; to take account of these particular operating conditions, the obturator seal of safety valve is in high resistance elastomer.

The knob is in plastic material especially resistant to increases in temperature and to UV rays, in the case of outdoor installations.

Chrome plating

The valve body is chrome plated to protect it from the aggression of dirt and moisture, in the case of outdoor installations of solar heating systems.

Certification

253 series safety relief valves are certified for specific use in solar heating systems by the certifying body TÜV, in accordance with standard SV 100 Ed. 10.01 par. 7.7.

Installation

The safety relief valves for solar systems must be installed near the point in the circuit where the system is filled, before expansion vessel.

Make sure that there are no shut-off devices between the valve and the rest of the system.

The safety relief valves can be fitted vertically or horizontally, but not upside down.

This prevents deposits of impurities from affecting correct functioning.

The safety relief valves must be installed in line with the flow direction indicated by the arrow on the valve body.

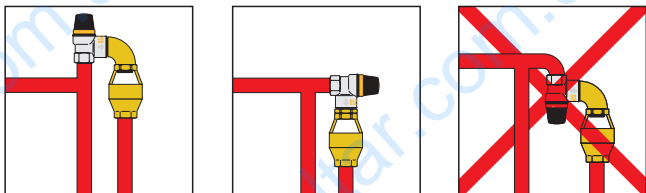

Application diagram

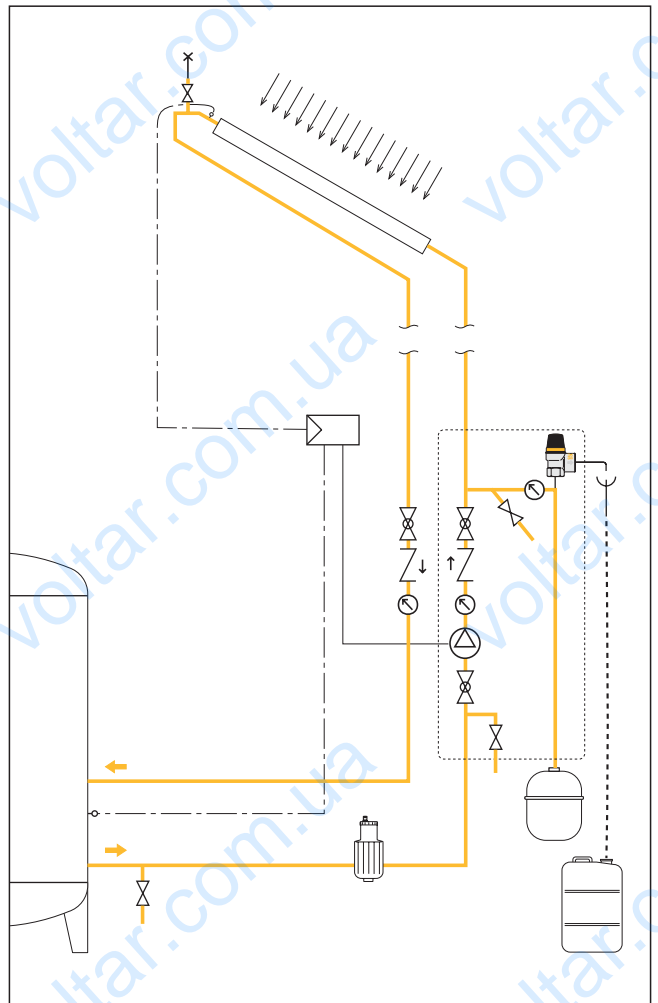

SPECIFICATION SUMMARIES

253 series

Safety relief valve for solar heating systems. CE mark as per Directive 97/23/EC. TÜV certified for solar systems. 1/2" F x 3/4" F threaded connections. Brass body. Chrome plated. Diaphragm and obturator seal in high resistance elastomer. Spring in steel UNI 3823. Control knob in PA6G30. Temperature range: -30–160°C. Nominal pressure: PN 10. Calibration setting: 3 bar (3, 4, 6, 8, 10 bar). Medium: water and glycol solutions. Maximum percentage of glycol: 50%.

We reserve the right to change our products and their relevant technical data, contained in this publication, at any time and without prior notice.