

User high-performance anti-scald thermostatic mixing valve



5213 series



01092/22 EN

replaces 01092/11 GB



Function

In some domestic hot water distribution systems there is a need to protect more vulnerable individuals against scalding caused by hot water, such as, for example hospitals, nursing homes or schools.

This particular series of thermostatic mixing valves has been specifically designed for this type of applications, for user outlets and installation at the point of use.

These thermostatic mixing valves ensure high thermal performance. They are able to control the temperature of the mixed water supplied to the user accurately in case of variations in the inlet supply pressure or temperature, or in the flow rate.

They also feature a special anti-scald function which immediately shuts off the hot water flow in the event of cold water supply failure at the inlet.

5213 series mixing valves are certified in accordance with the established specification in the UK, NHS D08, standard BS 7942:2000 and standards EN 1111 and EN 1287 (DN15 - DN20).



Product range

Code 521303	Adjustable anti-scald thermostatic mixing valve complete with inlet strainers and check valves	_____	DN 20 (3/4")
Code 521304	Adjustable anti-scald thermostatic mixing valve complete with inlet strainers and check valves	_____	size DN 15 (1/2")
Code 521315/322	Adjustable anti-scald thermostatic mixing valve complete with inlet strainers and check valves	_____	sizes DN 15 (Ø 15 mm) and DN 20 (Ø 22 mm) for copper pipe
Code 521306	Adjustable anti-scald thermostatic mixing valve complete with inlet strainers and check valves	_____	size DN 25 (1")

Technical specifications

Materials:

- Body: dezincification resistant alloy **CR** EN 12165 CW602N, chrome plated
- dezincification resistant alloy **CR** EN 12165 CW724R, chrome plated (code 521306)
- Obturator: PSU
- Springs: stainless steel EN 10270-3 (AISI 302)
- Seal elements: EPDM
- Cover: ABS

Performance

- Adjustment range: 30–50 °C
- Accuracy: ± 2 °C
- Maximum working pressure (static): 10 bar
- Maximum working pressure (dynamic): 5 bar
- Maximum inlet temperature: 85 °C
- Maximum inlet pressure ratio (H/C or C/H): 6:1
- 2:1 (DN 25)
- Minimum temperature difference between the inlet hot water and the outlet mixed water to ensure anti-scald performance: 10 °C
- Minimum flow rate for stable operation: 4 l/min
- 6 l/min (DN 25)
- Connections: 1/2" - 3/4" - 1" M (ISO 228-1)
- union with integrated check valve
- Ø 15 and Ø 22 mm with union and fitting for copper pipe

Dimensions

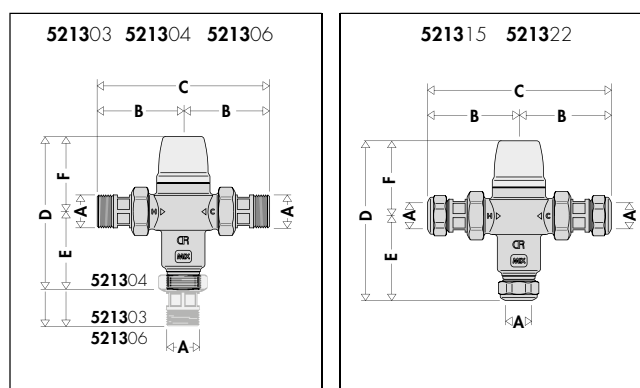

Code	DN	A	B	C	D	E	F	Mass (kg)
521303	20	3/4"	66,5	133	130	81,5	48,5	0,75
521304	15	1/2"	66,5	133	97,5	48,5	49	0,55
521306	25	1"	83,5	167	164,5	100,5	64	1,45
521315	15	Ø 15	67,5	135	105	56	49	0,50
521322	20	Ø 22	75	150	106	57	49	0,60

Legionella - scalding risk

In systems that produce domestic hot water with storage, in order to prevent the proliferation of dangerous *Legionella* bacteria the hot water must be stored at a temperature of at least 60 °C. At this temperature it is certain that the growth of the bacteria that cause Legionella infection will be totally inhibited; the water cannot however be used directly.

As shown in the diagram and table provided, temperatures over 50 °C can cause burns very quickly.

For example, at 55 °C, partial burn occurs in about 30 seconds, whereas at 60 °C partial burn occurs in about 5 seconds. On average, these times are halved for children and elderly people.

It is therefore necessary to use a thermostatic mixing valve able to:

- reduce the temperature at the point of use to a value lower than that of the storage and make it suitable for domestic utilities.
- keep the temperature constant in spite of variations in pressure and temperature at the inlet.
- offer an anti-scald safety function in the event of cold water supply failure at the inlet.

Thermal disinfection

The adjacent diagram shows the behaviour of *Legionella Pneumophila* bacteria as the temperature conditions of the water containing the bacteria vary.

To ensure correct thermal disinfection, it is necessary to go up to values of at least 60 °C.

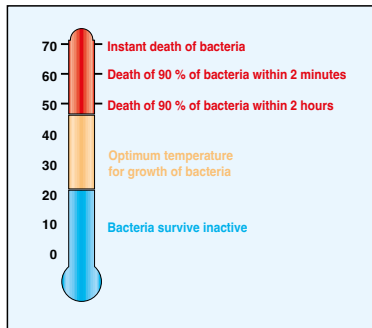

Temperature - Exposure time

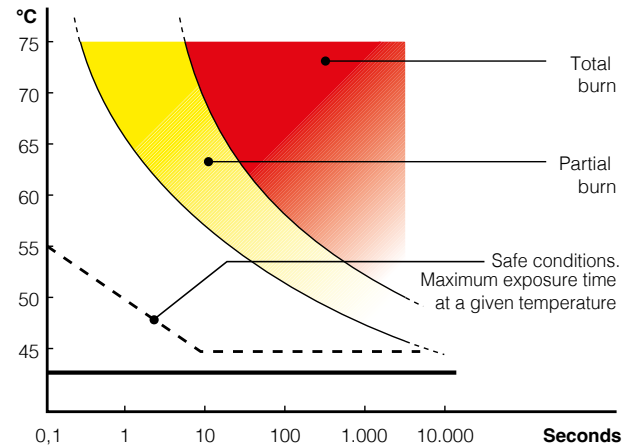

Exposure time required to cause partial burns

Temperature	Adults	Children 0-5 years
70 °C	1 s	--
65 °C	2 s	0,5 s
60 °C	5 s	1 s
55 °C	30 s	10 s
50 °C	5 min	2,5 min

Operating principle

The thermostatic mixing valve mixes the hot and cold water at the inlet so as to maintain the mixed water constantly at the set temperature at the outlet. A thermostatic element is fully immersed in the mixed water flow. It contracts or expands, moving an obturator which controls the passage of hot or cold water at the inlet. If the inlet temperature or pressure changes, the internal element automatically reacts to restore the set temperature at the outlet.

Construction details

Anti-scale materials

The materials used in constructing the mixing valve were selected to eliminate seizing due to limescale deposits. All functional parts have been made using a special anti-scale material with low friction coefficient, which ensures over time performance.

Anti-scald safety function

As a safety measure, in case of failure of the cold water supply at the inlet, the valve immediately shuts off the flow of the hot water. This prevents dangerous burns. This function is guaranteed if there is a minimum temperature difference between the hot water inlet and the mixed water outlet of 10 °C. Also in case of failure of the hot water supply at the inlet the valve shuts off the flow of mixed water at the outlet and therefore prevents dangerous thermal shocks in any case (performance in accordance with statutory legislation in the UK, NHS D08 and standard BS 7942:2000).

Threaded version

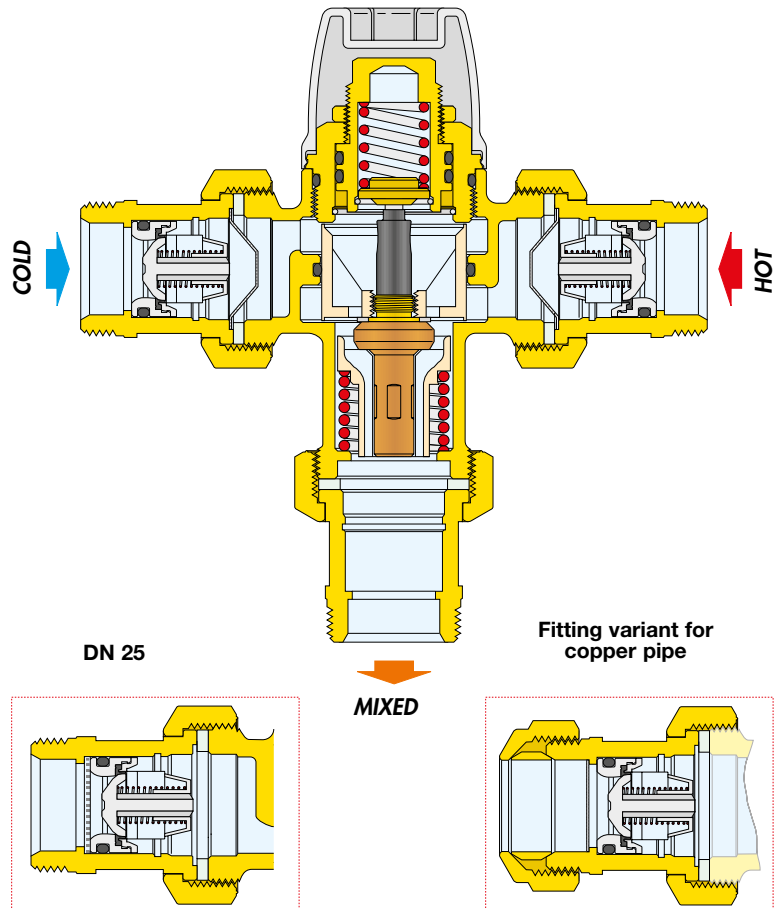

Thermal transients

During the transient, as a consequence of rapid changes in pressure, temperature or flow rate, the temperature increases with respect to the initial set point and this increase must be of limited duration to guarantee safety.

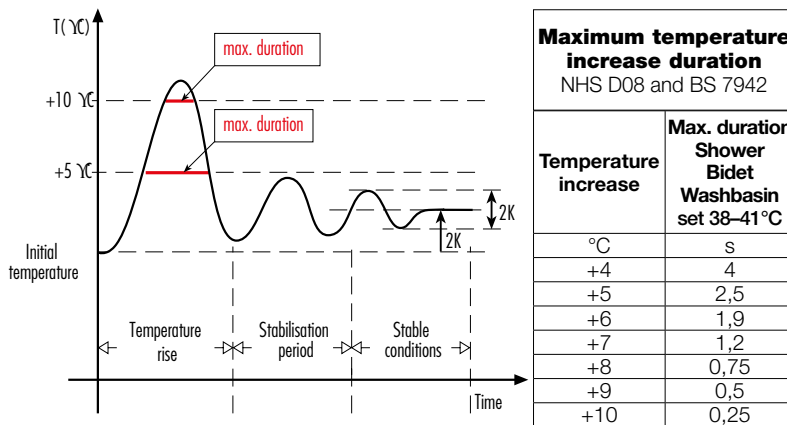

Hydraulic characteristics

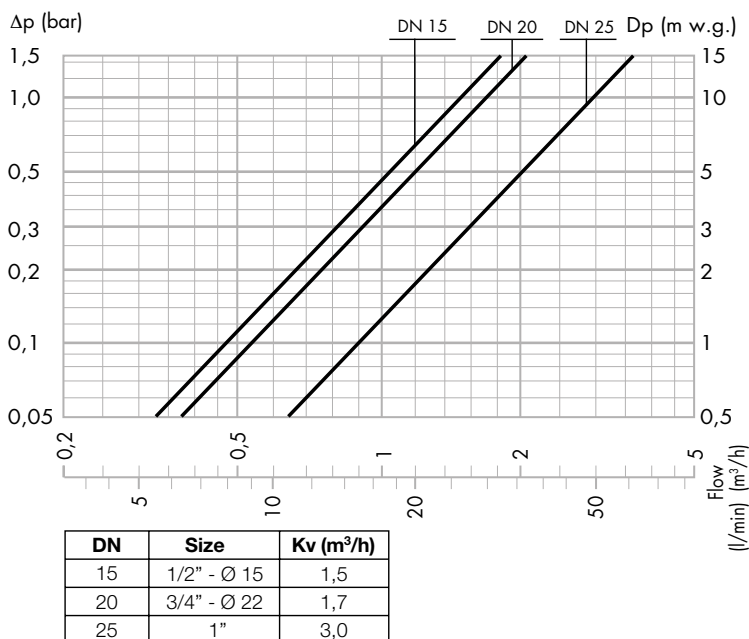

Utilisation

In view of its flow characteristics, the Caleffi 5213 series thermostatic mixing valve can be used for application at the point of use or for a limited number of user outlets. For this reason, the flow rate passing through the mixing valve is generally the same passing through the end user outlet, for example the tap of the washbasin, shower, bidet, etc. To ensure optimal performance, it is necessary to ensure the mixing valve has a minimum flow rate of 4 l/min - 6 l/min (DN 25). The system must always be sized in accordance with current legislation relating to the nominal flow rate for each user outlet.

Public buildings, hospitals, kindergartens

In this type of application, the risk of scalding is extremely high because of the type of people using the hot water, like children, old people and invalids. In these installations, the two supply networks providing hot water from the boiler and cold water may have different origins and operate at different pressures. In the event of cold water supply failure, the mixing valve is able to immediately shut off the outlet water in order to prevent the risk of scalding.

Selecting the mixing valve size

Given the design flow rate, taking into account simultaneous use of the domestic appliances, the mixing valve size should be selected by checking the pressure drop on the provided graph. In this case, it is necessary to check the available pressure, the pressure drop in the system downstream of the mixing valve and the residual pressure to be guaranteed for user appliances.



Sizing software available at www.caleffi.com,
Apple Store and Google play.

Installation

Before installing the mixing valve, the connecting pipes should be flushed to remove any impurities that could impair performance.

We recommend always installing strainers of sufficient capacity at the inlet from the water mains.

The 5213 series mixing valves are equipped with strainers at the hot and cold water inlets.

5213 series thermostatic tempering valves must be installed according to the diagrams shown in the instruction sheet or in this leaflet.

5213 series thermostatic mixing valves can be installed in any position, horizontally or vertically.

The following are indicated on the body of the mixing valve:

- hot water inlet, indicated by the letter "H" (Hot)
- cold water inlet, indicated by the letter "C" (Cold)
- mixed water outlet, indicated by the word "MIX".

Check valves

In systems with thermostatic mixing valves, check valves must be installed to prevent undesired backflow. 5213 series mixing valves are equipped with check valves at the hot and cold water inlets.

Commissioning

In view of the special applications of the thermostatic mixing valve, it must be commissioned in accordance with current regulations by qualified technicians, using appropriate temperature measurement equipment. We recommend using a digital temperature gauge for measuring the mixed water temperature.

Temperature adjustment and locking

The temperature is set at the desired value using the upper hexagonal screw through the slot on the protection cover.

Given the specific use of this type of mixing valve, the following table lists the maximum outlet water temperatures to prevent scalding.

Appliance	Tmax
Bidet	38 °C
Shower	41 °C
Washbasin	41 °C
Bathtub	44 °C

The temperature setting can then be locked at the desired value by means of the tamper-proof locking nut.

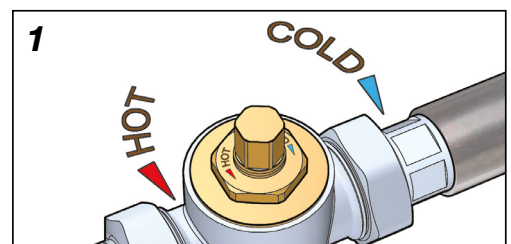

View of temperature adjustment

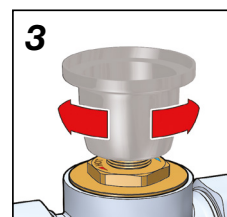

Using the cover for temperature adjustment

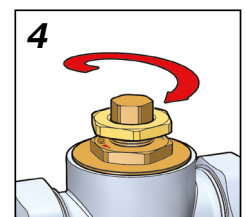

Locking the setting using the locking nut

Application diagrams

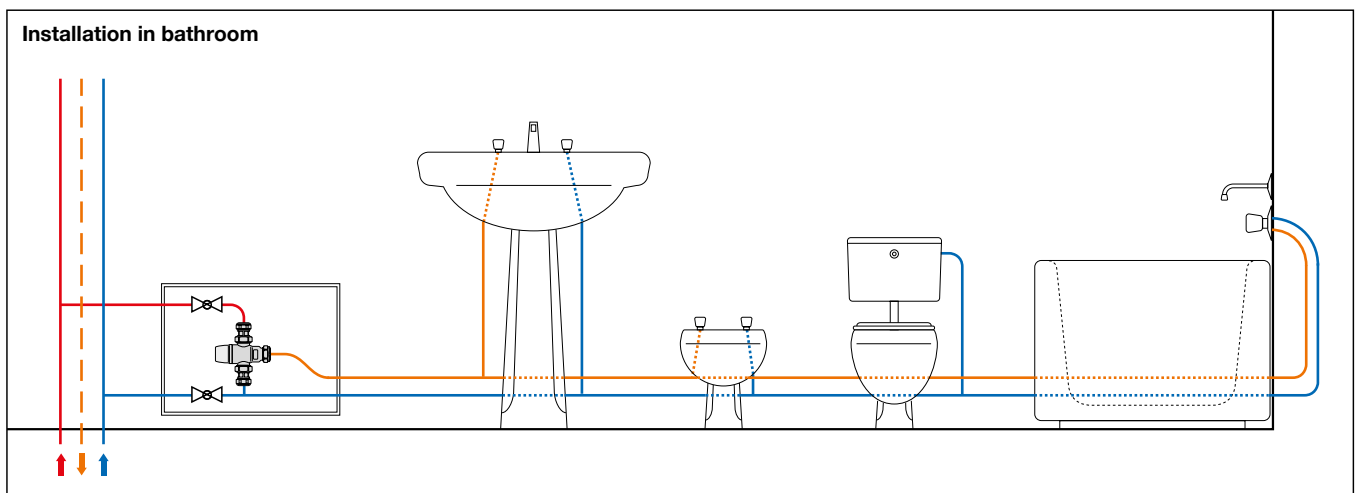
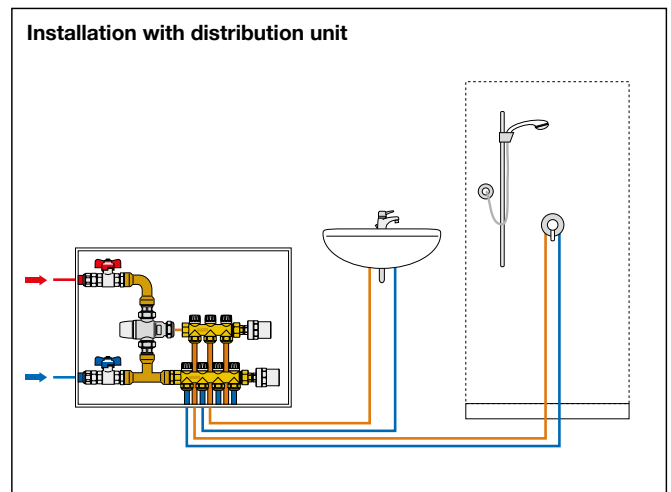
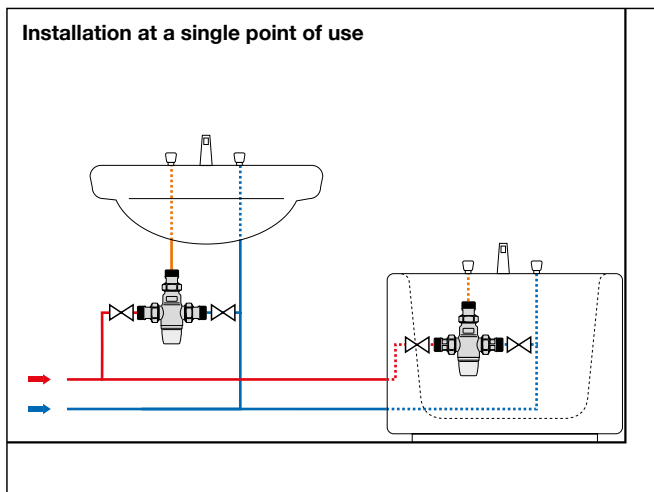

SPECIFICATION SUMMARY

Code 521303

Anti-scald thermostatic mixing valve. Certified in accordance with specifications NHS D08, BS 7942, EN 1111 and EN 1287. Size DN 20. Connections 3/4" M (ISO 228-1) with union. Dezincification resistant alloy body. Chrome plated. PSU obturator. Stainless steel springs. EPDM seal elements. ABS cover. Maximum working temperature 85 °C. Adjustment range 30–50 °C. Accuracy ± 2 °C. Maximum working pressure (static) 10 bar. Maximum working pressure (dynamic) 5 bar. Maximum inlet pressure ratio (H/C or C/H) 6:1. Equipped with anti-scald safety function and complete with strainers and check valves at the inlet.

5213 series.

Anti-scald thermostatic mixing valve. Certified in accordance with specifications NHS D08, BS 7942, EN 1111 and EN 1287. Size DN 15 (or DN 20). Connections $\varnothing 15$ (or $\varnothing 22$) for copper pipe. Dezincification resistant alloy body. Chrome plated. PSU obturator. Stainless steel springs. EPDM seal elements. ABS cover. Maximum working temperature 85 °C. Adjustment range 30–50 °C. Accuracy ± 2 °C. Maximum working pressure (static) 10 bar. Maximum working pressure (dynamic) 5 bar. Maximum inlet pressure ratio (H/C or C/H) 6:1. Equipped with anti-scald safety function and complete with strainers and check valves at the inlet.

Code 521306

Anti-scald thermostatic mixing valve. Size DN 25. Connections 1" M (ISO 228-1) with union. Dezincification resistant alloy body. Chrome plated. PSU obturator. Stainless steel springs. EPDM seal elements. ABS cover. Maximum working temperature 85 °C. Adjustment range 30–50 °C. Accuracy ± 2 °C. Maximum working pressure (static) 10 bar. Maximum working pressure (dynamic) 5 bar. Maximum inlet pressure ratio (H/C or C/H) 2:1. Equipped with anti-scald safety function and complete with strainers and check valves at the inlet.

We reserve the right to make changes and improvements to our products and the related technical data in this publication, at any time and without prior notice. The website www.caleffi.com always has the most up-to-date version of the document, which should be used for technical verifications.