

APPLICAZIONI

Elettropompe autoadescenti Jet Inox garantiscono un'ottima resa idraulica e una notevole capacità di pressione. Possono aspirare fino a 8 mt. di profondità e sono in grado di funzionare perfettamente anche in presenza di acque miscelate a gas. Adatte per l'alimentazione di acqua potabile, il sollevamento e la distribuzione negli impianti domestici a mezzo di piccoli e medi serbatoi (autoclavi).

APPLICATION

Selfpriming jet water pumps with a very high hydraulic performance and a considerable pressure capacity. Able to pump up to mt. 8 depth and work perfectly even in soda-water. Suitable for drinkable water, water lifting and distribution in domestic fittings by small and medium sized tanks.

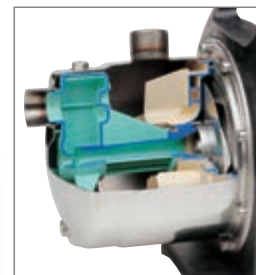

GIRANTE - IMPELLER

LIMITI D'IMPIEGO

- Temperatura liquido fino a 35°C (per un uso domestico secondo EN 60335-2-41)
- Temperatura max. liquido: 35°C (per altri impieghi)
- Temperatura ambiente fino a 40° C
- Altezza d'aspirazione manometrica fino a 8 mt.
- Servizio continuo

MOTORE

- Monofase 230V-50Hz
- Trifase 230/400V-50Hz
- Motore elettrico ad induzione a 2 poli (n = 2850 min⁻¹)
- Isolamento Classe F
- Protezione IP 44

MATERIALI

- | | |
|-----------------------|-----------------------|
| - Corpo pompa | Acciaio Inox AISI 304 |
| - Supporto motore | Alluminio |
| - Girante | Acciaio Inox AISI 304 |
| - Diffusore | Noryl |
| - Flangia portatenuta | Acciaio Inox AISI 304 |
| - Albero motore | Acciaio Inox AISI 304 |
| - Tenute meccaniche | Ceramica/Grafite/NBR |

OPERATING CONDITIONS

- Liquid temperature up to 35°C (for home use according to EN 60335-2-41)
- Temperature max. liquid: 35°C (for other uses)
- Ambient temperature up to 40°C
- Total suction lift up to 8 mt.
- Continuous duty

MOTOR

- Single-phase 230V-50Hz
- Three-phase 230/400V-50Hz
- Two-Pole induction motor (n = 2850 min⁻¹)
- Insulation Class F
- Protection IP 44

MATERIALS

- | | |
|--------------------|--------------------------|
| - Pump body | Stainless Steel AISI 304 |
| - Motor Support | Aluminium |
| - Impeller | Stainless Steel AISI 304 |
| - Diffuser | Noryl |
| - Pump flange | Stainless Steel AISI 304 |
| - Shaft with rotor | Stainless Steel AISI 304 |
| - Mechanical seal | Ceramic/Graphite/NBR |

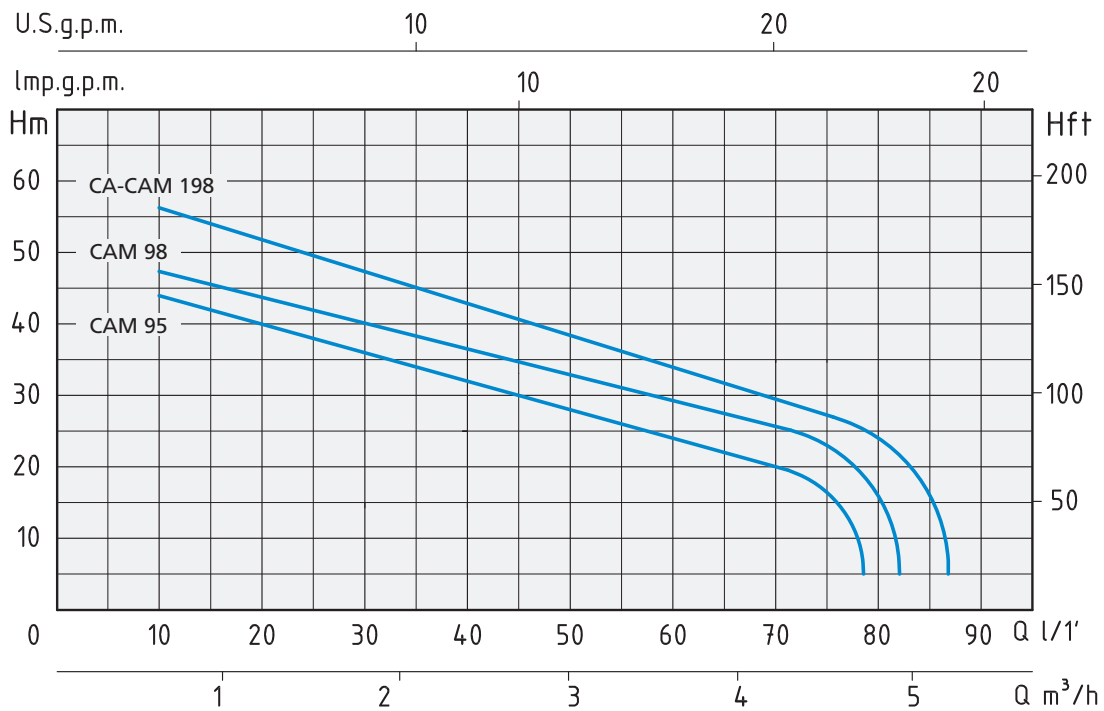

TIPO TYPE		POTENZA NOMINALE NOMINAL POWER		POTENZA ASSORBITA INPUT POWER	AMPERE		Q = PORTATA - CAPACITY										
Monofase Single-phase	Trifase Three-phase	P2		P1	Monofase Single-phase	Trifase Three-phase	m³/h	0,6	0,9	1,2	1,5	1,8	2,4	3	3,6	4,2	4,8
		HP	kW	kW			lt/1'	10	15	20	25	30	40	50	60	70	80
Prevalenza manometrica totale in m.C.A. - Total head in meters w.c.																	
CAM 95		1	0,75	1,1	5		H (m)	44	40	38	36	34	30	27	24	20	
CAM 98		1,3	1	1,3	5,8			47	45	44	41	39	35	32	28	26	
CAM 198	CA 198	1,6	1,1	1,7	7,5	4,2		56	53	50	48	46	42	36	34	30	25

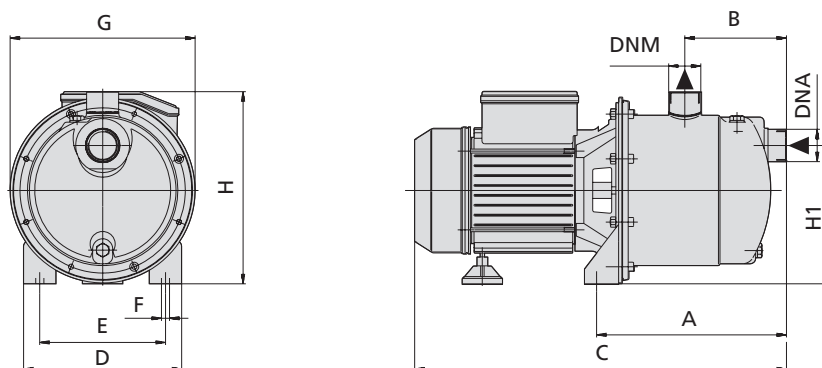

TIPO TYPE		DIMENSIONI mm - DIMENSIONS mm										DIMENSIONI DIMENSIONS mm			PESO WEIGHT	
Monofase Single-phase	Trifase Three-phase	A	B	C	D	E	F	G	H	H1	DNA	DNM	P	L	H	Kg
		CAM 95		210	113	415	176	140	9	206	212	154	1"	1"	212	453
CAM 98		210	113	415	176	140	9	206	212	154	1"	1"	212	453	230	11,4
CAM 198	CA 198	210	113	432	176	140	9	206	230	154	1" 1/4	1"	235	490	295	14,5