



SOFTENERS and MEDIA FILTERS

techno equipments

JUPITER

SOFTENERS

The water for drinking, sanitary or technological use, coming from the water system or from an autonomous supply, can be particularly hard, that is it can have a high concentration of calcium and magnesium salts. Precipitating, these salts create scaling, damage boilers, kettles, water systems and domestic appliances in general.

The JUPITER series water softeners by ATLAS FILTRI are made in compliance with the laws and regulations in force and make it possible to lower hardness with great benefits and savings in:

- sanitary hot and cold drinking water circuits
- hot water heating system boilers and their relative circuits
- steam boilers and their relative circuits as well as condensate return
- cooling and refrigerated water systems
- evaporative towers
- civil and industrial washing machines and dishwashers, launderettes
- process water for raw materials and unfinished products
- process water for the production of food, pharmaceutical and cosmetic products

The JUPITER Series water softeners offer hygienic-sanitary advantages (softer and cleaner laundry, greater detergent saving and longer clothing life).

The JUPITER water softeners utilize the exchange of calcium (Ca) and magnesium (Mg) ions with sodium (Na) ions, making the water to be softened flow on a strong cationic resin bed.

The resin is rich in sodium ions; the hard water is filtered and the ions responsible for the calcium and magnesium scaling are held on the surface of the resin and replaced with sodium ions, whose salts do not cause any deposits.

To ensure the treatment is effective, regenerate the filtering bed at regular intervals with an NaCl (brine) solution. This is done automatically by the multi-function controlling head, controlled by an electronic displacement timer/control. To be used in hot and cold sanitary drinking water circuits, the water softeners can be fitted with a by-pass and automatic resin-disinfection device (chlorine producer).

Non-toxic materials, suitable for drinking water.

- Control-valve: NORYL
- Tank: glass-fibre reinforced polyethylene
- Brine tank and cabinet: polyethylene
- Treating material: strong cationic ion-exchange resin

Remark: material for regeneration (NaCl) not provided with the softener.

REFILL: Strong cationic resin, package of 25 litres.

WORKING CONDITIONS

Max working pressure	6 bar
Min working pressure	2 bar
Max working temperature	50°C
Max concentration Fe	0,1 ppm
Max concentration free Cl	0,5 ppm
Electrical functioning	12V
Electrical absorption	8W

GUIDE TO THE CHOICE OF MODEL

JUPITER SOFTENERS

NUMBER OF USERS	WATER CONSUMPTION litres/day	WATER HARDNESS IN °f AND IN ppm				
		15-25°F 152-250 ppm	26-35°F 260-350 ppm	36-45°F 360-450 ppm	46-55°F 460-550 ppm	56-65°F 560-650 ppm
2	500	JUPITER 10	JUPITER 10	JUPITER 10	JUPITER 15	JUPITER 15
3 - 5	750 - 1250	JUPITER 15	JUPITER 30	JUPITER 30	JUPITER 30	JUPITER 50
6 - 10	1500 - 2500	JUPITER 30	JUPITER 50	JUPITER 50	JUPITER 70	JUPITER 70
11 - 15	2750 - 3750	JUPITER 50	JUPITER 70	JUPITER 70	JUPITER 100	JUPITER 120
16 - 20	4000 - 5000	JUPITER 50	JUPITER 70	JUPITER 100		
21 - 25	4250 - 6250	JUPITER 70	JUPITER 100	JUPITER 120		

ACCESSORY INCLUDED



total hardness drops

ACCESSORIES ON DEMAND



manual by-pass for 263/268 valve CODE EA1015037

manual by-pass for 255 valve CODE EA1015038



ATL chlorinator kit (electrodes) for disinfection of resins
CODE EA1015500

TECHNICAL FEATURES

Microprocessor dedicated electronics with the following characteristics:

- easily programmed display with dedicated keyboard
- disinfection system management (optional) during regeneration
- possible manual start of the regeneration process with guided progression through the various phases
- display of the regeneration phases and their duration
- memory autonomy up to 10 days (if the power supply is lacking)
- unit safety voltage 12V/50Hz

CERTIFICATIONS



The products are tested and certified under the most stringent procedures worldwide, in compliance with DM 25 (Italy) and with the sanitary certification EAC/Ghostreghistrizia (Russia).

SYMBOLS LEGEND



For domestic use



For technical and industrial use

INSTALLATION SCHEME

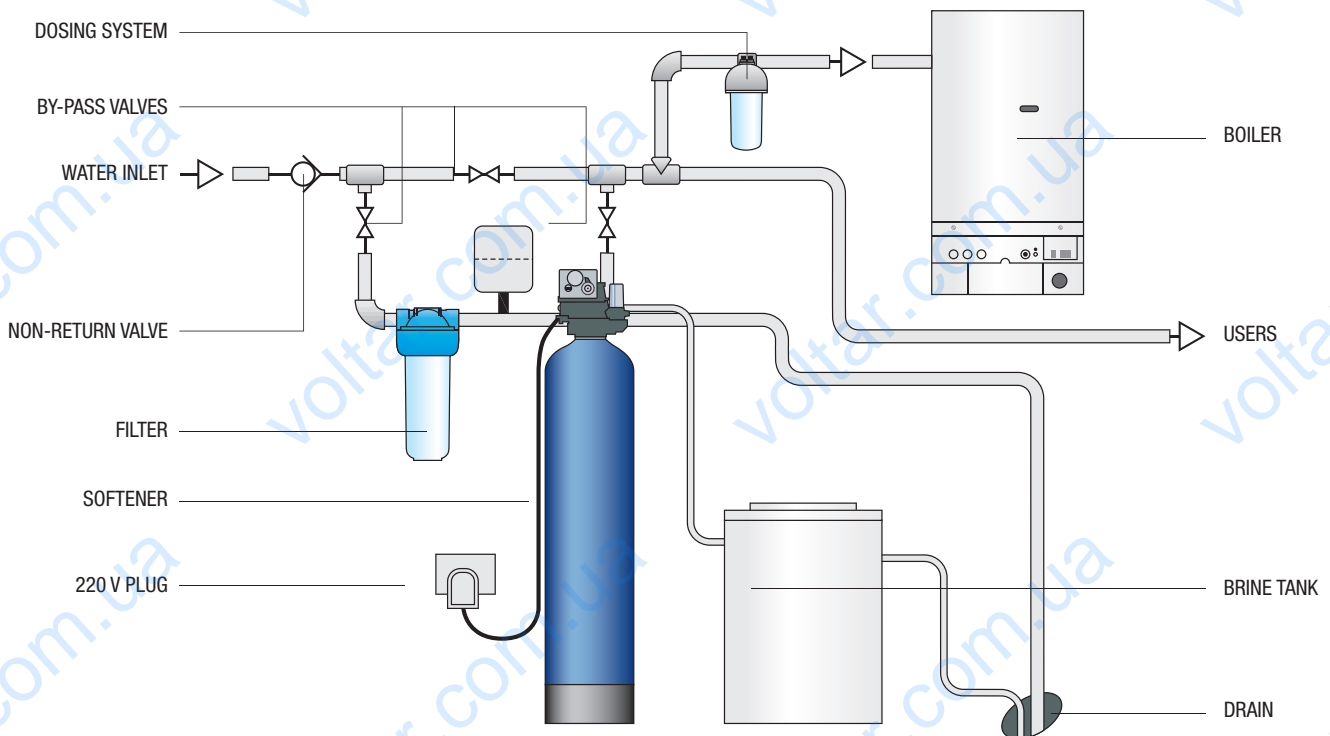
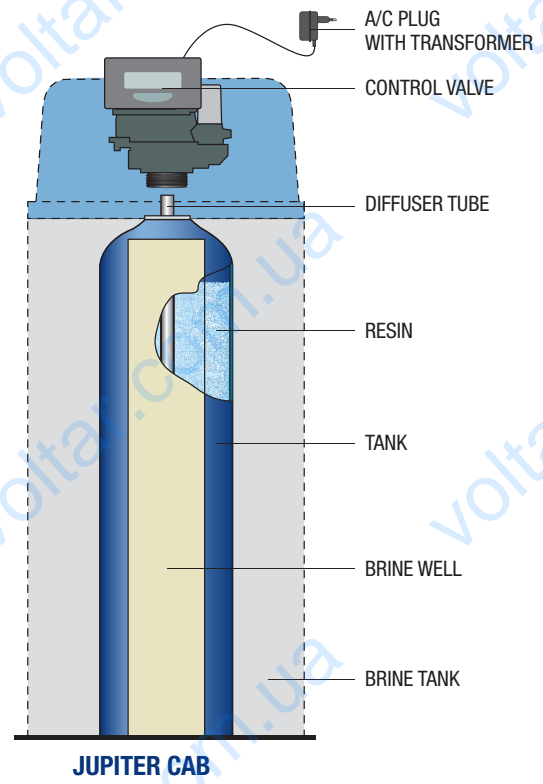
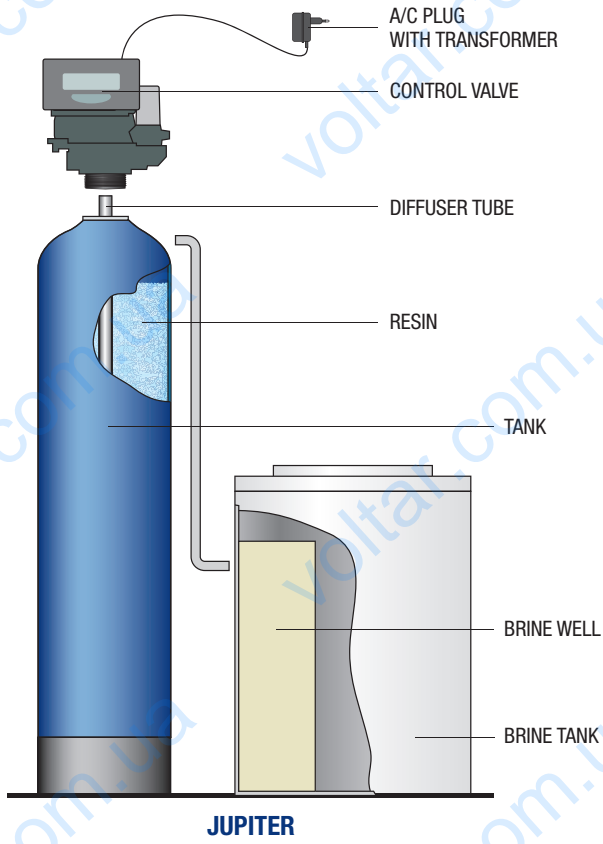



JUPITER CAB

- Compact version where the resin tank and brine tank are in one single unit. For small capacities, they make up an elegant and small solution to soften water for domestic use.

* The flow and cycle capacity data are calculated using 30°F (300 ppm CaCO₃) supply water, with a TDS of 500 ppm and a temperature of 20°C.



JUPITER CAB ATL

WITH TIMER CONTROL VALVE

CODE	MODEL	AUTOTROL VALVE	IN/OUT	RESIN [l]	CYCLE CAPACITY* [m ³ x °f]	BRINE CONSUMPTION [kg]	FLOW RATE* [m ³ /h]	MAX FLOW RATE* [m ³ /h]	BACK-WASH FLOW RATE [m ³ /h]
EA1000001	JUPITER CAB 05 ATL - MINICAB	LOGIX 255/740	3/4"	4,5	25	0,75	0,4	0,6	0,4
EA1000002	JUPITER CAB 10 ATL	LOGIX 255/740	3/4"	10	60	1,5	1,1	1,5	0,4
EA1000003	JUPITER CAB 15 ATL	LOGIX 255/740	3/4"	15	90	2,25	0,9	1,1	0,3
EA1000004	JUPITER CAB 30 ATL	LOGIX 255/740	3/4"	30	180	4,5	1,8	2,3	0,6

JUPITER CAB AVL

WITH VOLUMETRIC CONTROL VALVE

CODE	MODEL	AUTOTROL VALVE	IN/OUT	RESIN [l]	CYCLE CAPACITY* [m ³ x °f]	BRINE CONSUMPTION [kg]	FLOW RATE* [m ³ /h]	MAX FLOW RATE* [m ³ /h]	BACK-WASH FLOW RATE [m ³ /h]
EA1000005	JUPITER CAB 05 AVL - MINICAB	LOGIX 255/760	3/4"	4,5	25	0,75	0,4	0,6	0,4
EA1000006	JUPITER CAB 10 AVL	LOGIX 255/760	3/4"	10	60	1,5	1,1	1,5	0,4
EA1000007	JUPITER CAB 15 AVL	LOGIX 255/760	3/4"	15	90	2,25	0,9	1,1	0,3
EA1000008	JUPITER CAB 30 AVL	LOGIX 255/760	3/4"	30	180	4,5	1,8	2,3	0,6

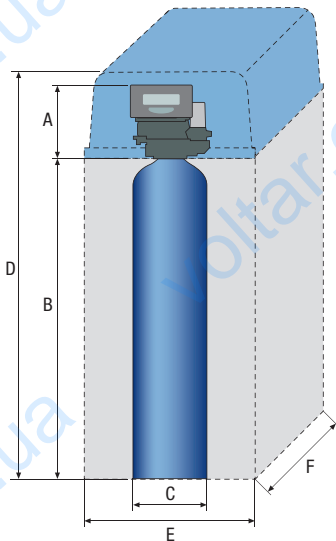

DIMENSIONS

MODEL	A [mm]	B [mm]	C [mm]	D [mm]	E [mm]	F [mm]	WEIGHT [kg]
JUPITER CAB 05 ATL - MINICAB	190	340	189	540	240	430	7
JUPITER CAB 10 ATL	190	432	214	650	330	500	18
JUPITER CAB 15 ATL	190	898	189	1130	330	500	26
JUPITER CAB 30 ATL	190	897	264	1130	330	500	40
JUPITER CAB 05 AVL - MINICAB	190	340	189	540	240	430	7
JUPITER CAB 10 AVL	190	432	214	650	330	500	18
JUPITER CAB 15 AVL	190	898	189	1130	330	500	26
JUPITER CAB 30 AVL	190	897	264	1130	330	500	40



JUPITER ATL

- Version where the resin tank is separated from the brine tank, suitable for both domestic and industrial use.

* The flow and cycle capacity data are calculated using 30°F (300 ppm CaCO₃) supply water, with a TDS of 500 ppm and a temperature of 20°C.

- **TIME (ATL):** regeneration valve with electronic timer automatically starting the regeneration at a time programmed by the user (for domestic use normally at night, when the demand for softened water is minimal). The unit allows programming of the time and frequency of the regeneration, from a minimum of 1 regeneration every 12 hours to a maximum of 1 every 99 days. Alternatively, the regeneration can be programmed for a fixed day in the week, always at the same time.



JUPITER ATL

WITH TIMER CONTROL VALVE

CODE	MODEL	AUTOTROL VALVE	IN/OUT	RESIN [l]	CYCLE CAPACITY* [m ³ x °f]	BRINE CONSUMPTION [kg]	FLOW RATE* [m ³ /h]	MAX FLOW RATE* [m ³ /h]	BACK-WASH FLOW RATE [m ³ /h]
EA1000009	JUPITER 10 ATL	LOGIX 255/740	3/4"	10	60	1,5	1,1	1,5	0,4
EA1000010	JUPITER 15 ATL	LOGIX 255/740	3/4"	15	90	2,25	0,9	1,1	0,3
EA1000011	JUPITER 30 ATL	LOGIX 255/740	3/4"	30	180	4,5	1,8	2,3	0,6
EA1000012	JUPITER 50 ATL	LOGIX 255/740	1"	50	300	7,5	2,1	2,5	0,6
EA1000013	JUPITER 70 ATL	LOGIX 255/740	1"	70	420	10,5	3	3,9	0,9
EA1000014	JUPITER 100 ATL	LOGIX 268/740	1"	100	600	15	3,5	4,5	1,1
EA1000015	JUPITER 120 ATL	LOGIX 268/740	1"	120	720	18	4,5	5,8	1,6

DIMENSIONS

MODEL	A [mm]	B [mm]	A + B [mm]	C [mm]	D [mm]	E [mm]	F [mm]	WEIGHT [kg]
JUPITER 10 ATL	190	432	622	214	790	380	380	18
JUPITER 15 ATL	190	898	1088	189	790	380	380	26
JUPITER 30 ATL	190	897	1087	264	790	380	380	40
JUPITER 50 ATL	190	1386	1576	264	825	565	565	63
JUPITER 70 ATL	190	1398	1588	338	825	565	565	82
JUPITER 100 ATL	180	1674	1854	365	1105	565	565	112
JUPITER 120 ATL	180	1671	1851	416	1105	565	565	120

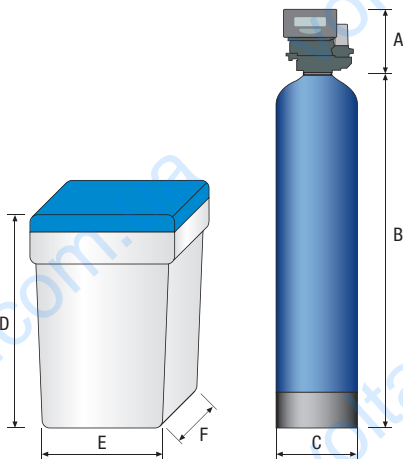



JUPITER AVL

- Version where the resin tank is separated from the brine tank, suitable for both domestic and industrial use.

* The flow and cycle capacity data are calculated using 30°F (300 ppm CaCO₃) supply water, with a TDS of 500 ppm and a temperature of 20°C.

- **VOLUME (AVL):** regeneration valve fitted with a flow sensor and a turbine meter checking the volume of the water treated. This version starts the regeneration at the selected time of the day chosen by the electronics according to the real water consumption, the exchange capacity and the set hardness. The unit allows programming in the following modes:

- time-volume: after reaching the set volume, at a set time.
- pure volume: immediately after reaching the set volume.



JUPITER AVL - AVM

WITH VOLUMETRIC CONTROL VALVE

CODE	MODEL	AUTOTROL VALVE	IN/OUT	RESIN [l]	CYCLE CAPACITY* [m ³ x °f]	BRINE CONSUMPTION [kg]	FLOW RATE* [m ³ /h]	MAX FLOW RATE* [m ³ /h]	BACK-WASH FLOW RATE [m ³ /h]
EA1000026	JUPITER 10 AVL	LOGIX 255/760	3/4"	10	60	1,5	1,1	1,5	0,4
EA1000027	JUPITER 15 AVL	LOGIX 255/760	3/4"	15	90	2,25	0,9	1,1	0,3
EA1000028	JUPITER 30 AVL	LOGIX 255/760	3/4"	30	180	4,5	1,8	2,3	0,6
EA1000029	JUPITER 50 AVL	LOGIX 255/760	1"	50	300	7,5	2,1	2,5	0,6
EA1000030	JUPITER 70 AVL	LOGIX 255/760	1"	70	420	10,5	3	3,9	0,9
EA1000031	JUPITER 100 AVL	LOGIX 268/760	1"	100	600	15	3,5	4,5	1,1
EA1000032	JUPITER 120 AVL	LOGIX 268/760	1"	120	720	18	4,5	5,8	1,6

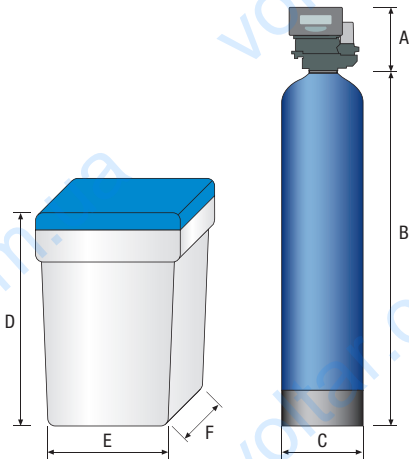

DIMENSIONS

MODEL	A [mm]	B [mm]	A + B [mm]	C [mm]	D [mm]	E [mm]	F [mm]	WEIGHT [kg]
JUPITER 10 AVL	190	432	622	214	790	380	380	18
JUPITER 15 AVL	190	898	1088	189	790	380	380	26
JUPITER 30 AVL	190	897	1087	264	790	380	380	40
JUPITER 50 AVL	190	1386	1576	264	825	565	565	63
JUPITER 70 AVL	190	1398	1588	338	825	565	565	82
JUPITER 100 AVL	180	1674	1854	365	1105	565	565	112
JUPITER 120 AVL	180	1671	1851	416	1105	565	565	120