

MAINTENANCE-FREE BATTERY VRLA AGM

100Ah 12V

INDEKS: 6AKUXAG100
EAN: 5903760240752

AGM VRLA batteries by VOLT Polska are designed with **VRLA AGM (Absorbent Glass Mat)** technology, high performance plates and electrolyte to give extra power output for common power backup system. **The general features are:** heavy duty grid, non-spillable construction, mechanized assembly, high reliability and stability, sealed and maintenance-free, long life and low self-discharge design. They can be applied in emergency power system, communication equipment, alarm system, telecommunication systems, marine equipment, uninterruptible power supplies, medical equipment, fire and security system.



Main technical data:

Nominal voltage	12 V	
Rated capacity	100 Ah	
Dimension	total height	218 mm
	height	213 mm
	width	173 mm
	length	331 mm
Approx Weight	24kg +/- 3%	
Gross dimensions	36,4x20,3x26,5cm	
Gross weight	24kg	

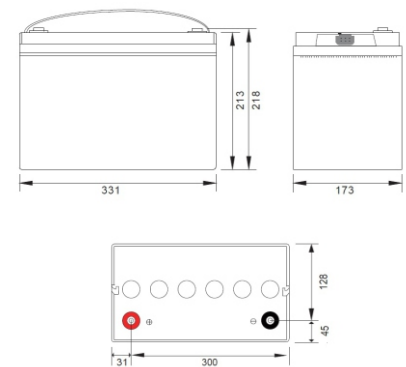

Dimension

Other specification:

Internal Resistance	~ 5,6 mΩ	
Capacity affected by temperature	40°C	102%
	25°C	100%
	0°C	85%
	-15°C	65%
Self discharge (at 25°C)	3 months	91%
	6 months	82%
	12 months	65%
Working temperature	25°C +/- 3°C	
Working temperature	Discharge	-15°C do 50°C
	Charge	-10°C do 50°C
	Storage	-20°C do 50°C
Float Use (25°C)	13,5 VDC	13,8 VDC
Cycle Use (25°C)	14,4 VDC	14,7 VDC
Max charging current	22,5 A	
Max discharge current	750 A (per 5 s)	
Design life (25°C)	3-5years	

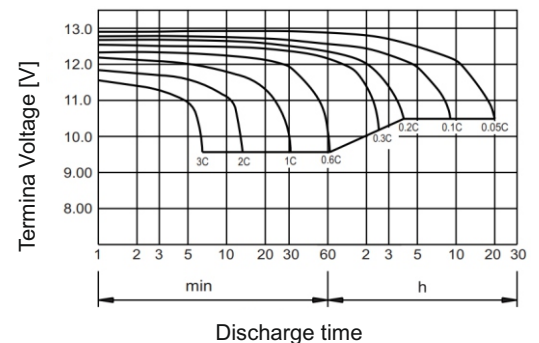

Discharge characteristic curve at 25°C

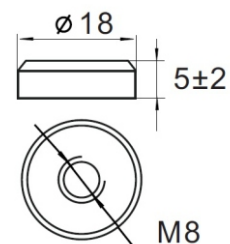

Terminal type (mm):