

MAXIMUM USER'S

Instructions and recommendations

Installer

User

Maintenance technician



**VICTRIX TERA
V228-32-38 EU**

1.047820ENG



INDEX

Dear Customer.....	4
General Recommendations.....	5
Safety symbols used.....	6
Personal protective equipment	6
1 Unit installation	7
1.1 Installation warnings.....	7
1.2 Main dimensions.....	12
1.3 Minimum installation distances	13
1.4 Antifreeze protection.....	13
1.5 Installation inside the recessed frame (Optional)	15
1.6 Appliance connection unit	16
1.7 Gas connection	17
1.8 Hydraulic connection	18
1.9 Electrical connection	19
1.10 Remote controls and room chrono-thermostats (Optional)	21
1.11 External temperature probe (Optional).....	22
1.12 Immergas flue systems	23
1.13 Tables of resistance factors and equivalent lengths of “Green Range” flue system components.....	25
1.14 Outdoor installation in partially protected area	27
1.15 Internal installation using a recessed frame with direct air intake.....	29
1.16 Concentric horizontal kit installation.....	30
1.17 Concentric vertical kit installation.....	32
1.18 Separator kit installation	34
1.19 C9 adaptor kit installation	36
1.20 Ducting of flues or technical slots.....	38
1.21 Configuration type B, open chamber and fan assisted for indoors.....	39
1.22 Flue exhaust to flue/chimney.....	39
1.23 Flues, chimneys and chimney caps.....	40
1.24 Water treatment plant filling.....	41
1.25 System filling.....	42
1.26 Filling the condensate drain trap	42
1.27 Gas system start-up.....	42
1.28 Appliance start-up (Ignition).....	43
1.29 Circulation pump	44
1.30 Kits available on request.....	47
1.31 Main components.....	48
2 Instructions for use and maintenance	49
2.1 General recommendations.....	49
2.2 Cleaning and maintenance.....	51
2.3 Control panel	51
2.4 Using the appliance	52
2.5 Fault and anomaly signals.....	54
2.6 Information menu	57
2.7 Appliance switch-off.....	58
2.8 Restore central heating system pressure.....	58
2.9 Draining the system	58
2.10 Emptying the D.H.W. circuit.....	58
2.11 Antifreeze protection.....	59
2.12 Cleaning the case	59
2.13 Permanent shutdown.....	59
3 Instructions for maintenance and initial check.....	60

3.1	General recommendations.....	60
3.2	Initial check.....	61
3.3	Yearly appliance check and maintenance.....	62
3.4	Hydraulic diagram.....	64
3.5	Wiring diagram.....	65
3.6	Troubleshooting.....	66
3.7	Converting the appliance to other types of gas.....	67
3.8	Fan speed calibration.....	68
3.9	CO ₂ /O ₂ regulation.....	69
3.10	Checks following conversion to another type of gas.....	69
3.11	P.C.B. programming.....	70
3.12	Password-protected special functions.....	76
3.13	Screen heater function.....	77
3.14	Automatic vent function (dl).....	78
3.15	Flue installation (FU).....	78
3.16	Maintenance function (MA).....	78
3.17	Chimney sweep function.....	79
3.18	Solar panels coupling function.....	80
3.19	Pump anti-block function.....	80
3.20	Three-way anti-block system.....	80
3.21	Radiators antifreeze function.....	80
3.22	Casing removal.....	81
3.23	Replacing the manifold insulating panel.....	84
3.24	Replacing manifold seals.....	86
3.25	Assembling the manifold on the condensation module.....	88
4	Technical data.....	89
4.1	Variable heat output.....	89
4.2	Combustion parameters.....	92
4.3	Technical data table.....	94
4.4	Key for data nameplate.....	95
4.5	Technical parameters for combination boilers (in compliance with Regulation 813/2013).....	96
4.6	Product fiche (in compliance with Regulation 811/2013).....	99
4.7	Parameters for filling in the package fiche.....	102

Dear Customer

Congratulations for having chosen a top-quality Immergas product, able to assure well-being and safety for a long period of time. As an Immergas customer you can also count on a Qualified Authorised After-Sales Technical Assistance Centre, prepared and updated to guarantee constant efficiency of your appliance. Read the following pages carefully: you will be able to draw useful tips on the proper use of the device, compliance with which will confirm your satisfaction with the Immergas product.

For assistance and routine maintenance, contact Authorised Technical Service Centres: they have original spare parts and are specifically trained directly by the manufacturer.

The company **IMMERGAS S.p.A.**, with registered office in via Cisa Ligure 95 42041 Brescello (RE), declares that the design, manufacturing and after-sales assistance processes comply with the requirements of standard **UNIENISO 9001:2015**.

For further details on the product CE marking, request a copy of the Declaration of Conformity from the manufacturer, specifying the appliance model and the language of the country.

The manufacturer declines all liability due to printing or transcription errors, reserving the right to make any modifications to its technical and commercial documents without forewarning.



GENERAL RECOMMENDATIONS

This book contains important information for the:

Installer (section 1);

User (section 2);

Maintenance Technician (section 3).

- The user must carefully read the instructions in the specific section (section 2).
 - The user must limit operations on the appliance only to those explicitly allowed in the specific section.
 - The instruction booklet is an integral and essential part of the product and must be given to the new user in the case of transfer or succession of ownership.
 - It must be stored with care and consulted carefully, as all of the warnings provide important safety indications for installation, use and maintenance stages.
 - In compliance with the legislation in force, the systems must be designed by qualified professionals, within the dimensional limits established by the Law. Installation and maintenance must be performed in compliance with the regulations in force, according to the manufacturer's instructions and by professionally qualified staff, meaning staff with specific technical skills in the plant sector, as provided for by Law.
 - Improper installation or assembly of the Immergas device and/or components, accessories, kits and devices can cause unexpected problems for people, animals and objects. Read the instructions provided with the product carefully to ensure proper installation.
 - This instructions manual provides technical information for installing Immergas products. As for the other issues related to the installation of products (e.g. safety at the workplace, environmental protection, accident prevention), it is necessary to comply with the provisions of the standards in force and the principles of good practice.
 - All Immergas products are protected with suitable transport packaging.
 - The material must be stored in a dry place protected from the weather.
 - Damaged products must not be installed.
 - Maintenance must be carried out by skilled technical staff. For example, the Authorised Service Centre that represents a guarantee of qualifications and professionalism.
 - The appliance must only be destined for the use for which it has been expressly declared. Any other use will be considered improper and therefore potentially dangerous.
 - If errors occur during installation, operation and maintenance, due to non-compliance with technical laws in force, standards or instructions contained in this booklet (or however supplied by the manufacturer), the manufacturer is excluded from any contractual and extra-contractual liability for any damages and the device warranty is invalidated.
 - In the event of malfunctions, faults or incorrect operation, turn the appliance off and contact an authorised company (e.g. the Authorised Technical Assistance Centre, which has specifically trained staff and original spare parts). Do not attempt to modify or repair the appliance alone.
-

SAFETY SYMBOLS USED



GENERIC HAZARD

Strictly follow all of the indications next to the pictogram. Failure to follow the indications can generate hazard situations resulting in possible harm to the health of the operator and user in general, and/or property damage.



ELECTRICAL HAZARD

Strictly follow all of the indications next to the pictogram. The symbol indicates the appliance's electrical components or, in this manual, identifies actions that can cause an electrical hazard.



MOVING PARTS

The symbol indicates the appliance's moving components that can cause hazards.



DANGER OF HOT SURFACES

The symbol indicates the appliance's very hot components that can cause burns.



WARNINGS

Strictly follow all of the indications next to the pictogram. Failure to follow the indications can generate hazard situations resulting in possible minor injuries to the health of both the operator and the user in general, and/or slight material damage.



ATTENTION

Read and understand the instructions of the appliance before carrying out any operation, carefully following the instructions given. Failure to observe the instructions may result in malfunction of the unit.



INFORMATION

Indicates useful tips or additional information.



EARTH TERMINAL CONNECTION

The symbol identifies the appliance's earth terminal connection point.



DISPOSAL WARNING

The user must not dispose of the appliance at the end of its service life as municipal waste, but send it to appropriate collection centres.

PERSONAL PROTECTIVE EQUIPMENT



SAFETY GLOVES



EYE PROTECTION



SAFETY FOOTWEAR

1 UNIT INSTALLATION

1.1 INSTALLATION WARNINGS



Operators who install and service the appliance must wear the personal protective equipment required by applicable law.



This appliance has been designed for wall mounted installation only, for central heating and production of domestic hot water for domestic use and similar purposes.



The place of installation of the appliance and relative Immergas accessories must have suitable features (technical and structural), such as to allow for (always in safe, efficient and comfortable conditions):

- installation (according to the provisions of technical legislation and technical regulations);
- maintenance operations (including scheduled, periodic, routine and special maintenance);
- removal (to outdoors in the place for loading and transporting the appliances and components) as well as the eventual replacement of those with appliances and/or equivalent components.



The wall surface must be smooth, without any protrusions or recesses enabling access to the rear part. They are not designed to be installed on plinths or floors (Fig. 1).



By varying the type of installation the classification of the appliance and precisely:

- **Type B₂₃ or B₅₃** appliance if installed using the relevant terminals for air intake directly from the room in which the appliance has been installed.
- **Type C appliance** if installed using concentric pipes or other types of pipes envisioned for the sealed chamber appliance for intake of air and expulsion of flue gas.



The equipment classification is shown in the illustrations of the various installation solutions on the following pages.



Only professionally enabled companies are authorised to install Immergas gas appliances.



Installation must be carried out according to regulation standards, current legislation and in compliance with local technical regulations and the required technical procedures.

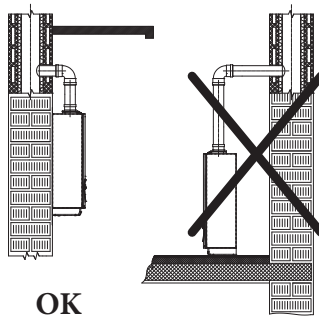

1



It is forbidden to install appliances removed from other systems.

The manufacturer declines all liability in the event of damage caused by appliances removed from other systems or for any non-conformities with such equipment.



Check the environmental operating conditions of all parts relevant to installation, referring to the values shown in the technical data table in this booklet.



Installation of the appliance when powered by LPG or propane air must comply with the rules regarding gases with a greater density than air (remember, as an example, that it is prohibited to install plants powered with the above-mentioned gas in rooms where the floor is at a lower quota than the country level).



Before installing the appliance, ensure that it is delivered in perfect condition; if in doubt, contact the supplier immediately. Packing materials (staples, nails, plastic bags, polystyrene foam, etc.) constitute a hazard and must be kept out of the reach of children.

If the appliance is installed inside or between cabinets, ensure sufficient space for normal servicing; therefore it is advisable to leave clearance of at least 3 cm between the boiler casing and the vertical sides of the cabinet. Leave adequate space above and below the boiler to enable interventions on the water and flue removal connections (Fig.3).



It is just as important that the intake grids and exhaust terminals are not obstructed.



It is recommended to check that no flue gas recirculation is found in the air sample points (0.5% maximum permitted CO₂).



Keep all flammable objects away from the appliance (paper, rags, plastic, polystyrene, etc.).



Split exhaust ducts must not pass through walls of flammable material.



Do not place household appliances underneath the appliance as they could be damaged if the safety valve intervenes, if the drain trap is blocked, or if there are leaks from the hydraulic connections; otherwise, the manufacturer cannot be held responsible for any damage caused to the household appliances.



For the aforementioned reasons, we recommend not placing furnishings, furniture, etc. under the appliance.



In the event of malfunctions, faults or incorrect operation, turn the appliance off and contact an authorised company (e.g. the Authorised Technical Assistance Centre, which has specifically trained staff and original spare parts). Do not attempt to modify or repair the appliance alone.



Any modification to the appliance that is not explicitly indicated in this section of the booklet is forbidden.

Installation standards



This type of installation is possible when permitted by the laws in force in the appliance's country of destination.



This appliance can be installed outdoors in a partially protected area. By partially protected area, we mean one in which the unit is not directly exposed to the elements (rain, snow, hail, etc.).



Installation of gas appliances, flue exhaust pipes and combustion air intake pipes is forbidden in places with a fire risk (for example: garages, closed parking stalls), and in potentially dangerous places.



Do not install on the vertical projection of hobs.



Do not install in places/rooms that constitute public areas of apartment buildings, internal stairways or other escape routes (e.g. floor landings, entrance halls, etc.).



Installation is also forbidden in places/rooms that constitute public areas of apartment buildings such as cellars, entrance halls, attics, lofts, etc., unless otherwise provided for by local regulations in force.



These appliances, if not adequately isolated, are not suitable for installation on walls of combustible material.



Installing the wall recessed frame kit must guarantee the boiler stable, efficient support.

The recessed frame kit ensures appropriate support only if installed correctly (according to the rules of good practice), following the instructions on its instructions leaflet.

The recessed frame for the boiler is not a supporting structure and must not replace the wall removed. It is necessary to position the boiler inside the wall.

For safety reasons against any leaks it is necessary to plaster the boiler housing in the brick wall.



Wall mounting of the appliance must guarantee stable and efficient support for the generator.

The plugs (standard supply) that come with the appliance are only to be used to fix the latter to the wall; they only ensure adequate support if inserted correctly (according to technical standards) in walls made of solid or semi-hollow brick or block. In the case of walls made from hollow brick or block, partitions with limited static properties, or in any case walls other than those indicated, a static test must be carried out to ensure adequate mount. Appliances must be installed in such a way as to avoid knocks or tampering.



These appliances are used to heat water to below boiling temperature in atmospheric pressure.



They must be connected to a central heating system and domestic hot water circuit suited to their performance and capacity.

Risk of damage due to corrosion caused by unsuitable combustion air and environment.



Spray, solvents, chlorine-based detergents, paints, glue, ammonium compounds, powders and similar cause product and flue duct corrosion.



Check that combustion air power supply is free from chlorine, sulphur, powders, etc.



Make sure that no chemical substances are stored in the place of installation.



If you want to install the product in beauty salons, paint workshops, carpenter's shop, cleaning companies or similar, choose a separate installation area that ensures combustion air supply that is free from chemical substances.



Make sure the combustion air is not fed through chimneys that were previously used with boilers or other central heating appliances powered by liquid or solid fuels. In fact, these may cause an accumulation of soot in the chimney

Risk of material damage after using sprays and liquids to search for leaks

PX42 Gas Valve



Leak sprays and liquids clog the reference hole P1. Ref. (Fig. 42) of the gas valve, damaging it irreparably. During installation and maintenance, do not use spray or liquids in the upper area of the gas valve (side referring to the electric connections).

SIT 848 GAS Valve



Leak sprays and liquids clog the reference hole PR Ref. (Fig. 43) of the gas valve, damaging it irreparably. During installation and maintenance, do not use spray or liquids in the upper area of the gas valve (side referring to the electric connections).

Filling the condensate drain trap



When the appliance is switched on for the first time, combustion products come out of the condensate drain. After a few minutes of operation, check that combustion flue gases are no longer coming out of the condensate drain; this means that the drain trap has filled to a correct condensate height that the flue gases cannot pass through.



Open chamber appliances type B₂₃ and B₅₃ must not be installed in rooms in which commercial, craft or industrial activities are carried out where products are used that are capable of developing vapours or volatile substances (e.g. acid vapours, glues, paints, solvents, fuels, etc.), as well as dust (e.g. dust from wood processing, coal dust, cement dust, etc.) that could be harmful to the appliance's components and impair its operation.



In configuration B₂₃ and B₅₃, unless local regulations are in force, the appliances must not be installed in bedrooms, bathrooms, toilets or studios; they must neither be installed in rooms containing solid fuel heat generators nor in rooms communicating with said rooms.



The installation rooms must be permanently ventilated, in compliance with the local regulations in force (at least 6 cm² for every kW of installed heat input, except in the event of any increases needed for electro-mechanical vacuum cleaners or other devices that could put the installation room under vacuum).



Install the appliances in B₂₃ and B₅₃ configuration in non-residential premises and which are permanently ventilated.



Failure to comply with the above implies personal responsibility and invalidates the warranty.

INSTALLER

USER

MAINTENANCE TECHNICIAN

TECHNICAL DATA

1.2 MAIN DIMENSIONS

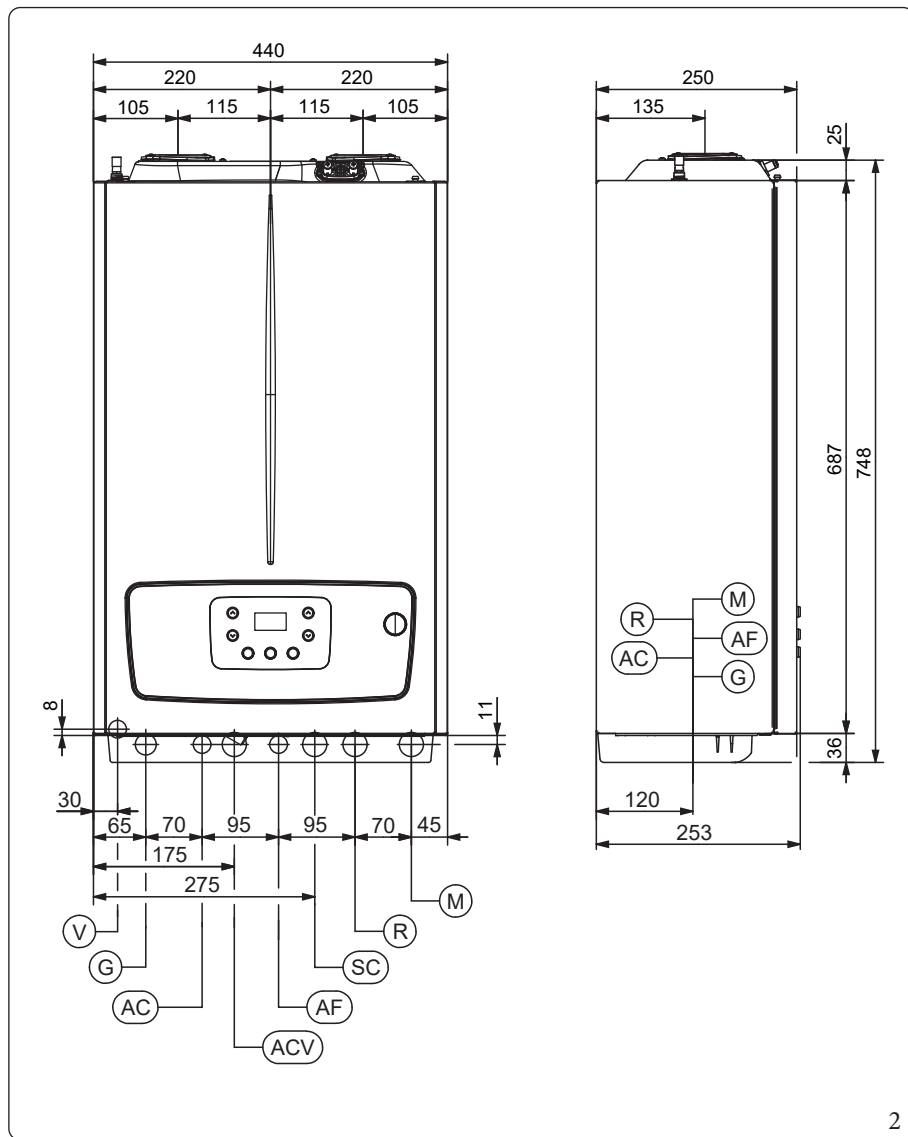

Key (Fig. 2):

- V - Electrical connection
- G - Gas supply
- AC - Domestic hot water outlet
- ACV - Solar valve kit DHW inlet (optional)
- AF - Domestic hot water inlet
- SC - Condensate drain (minimum internal diameter Ø 13 mm)
- M - System flow
- R - System return

Height (mm)	Width (mm)		Depth (mm)	
748	440		253	
CONNECTIONS				
GAS	D.H.W.		SYSTEM	
G	AC	AF	R	M
3/4"	1/2"	1/2"	3/4"	3/4"

1.3 MINIMUM INSTALLATION DISTANCES

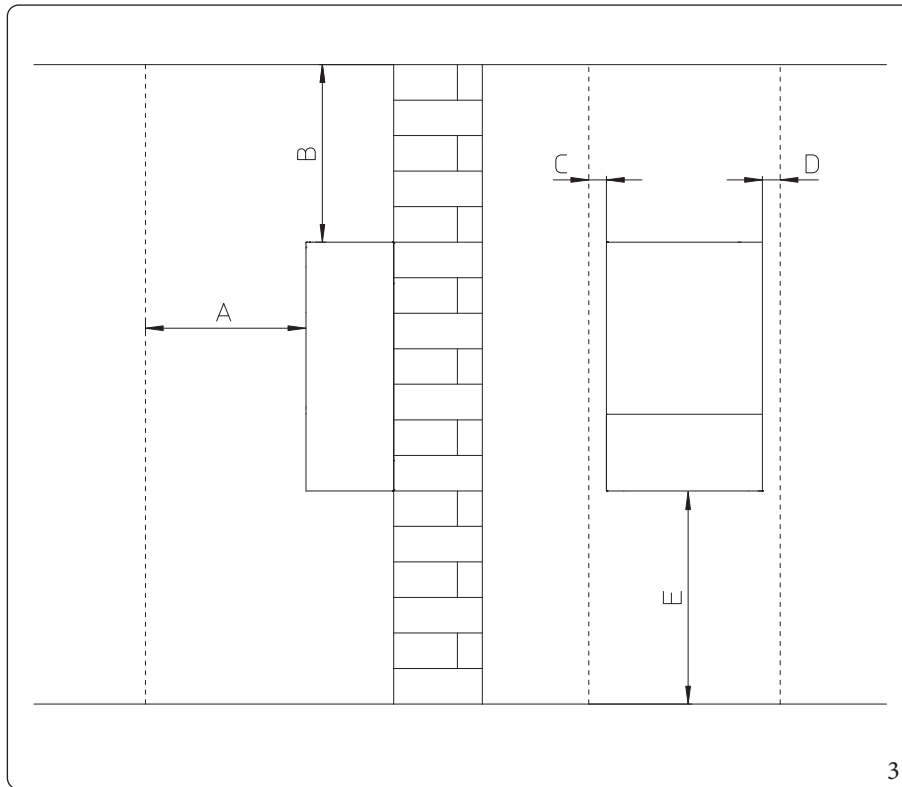

Key (Fig. 3):

- A - 450 mm
- B - 350 mm
- C - 30 mm
- D - 30 mm
- E - 350 mm

1.4 ANTIFREEZE PROTECTION

Minimum temperature -5°C

The appliance comes as per standard with an antifreeze function that activates the pump and the burner when the system water temperature in the appliance falls below 4°C.



In these conditions, previously listed, the appliance is protected against freezing up to an ambient temperature of -5°C.



If the appliance is installed in a place where the temperature drops below -5°C, the appliance may freeze.

To prevent the risk of freezing follow the instructions below:



The excessive use of glycol could jeopardise the proper functioning of the appliance.

- Protect the central heating circuit from freezing by inserting a good-quality antifreeze liquid into this circuit, which is specially suited for central heating systems and which is manufacturer guaranteed not to cause damage to the heat exchanger or other components of the appliance. The antifreeze liquid must not be harmful to one's health. The instructions of the manufacturer of this liquid must be strictly followed regarding the necessary percentage with respect to the minimum temperature at which the system must be kept.
- The materials used for the central heating circuit of Immergas appliances resist propylene glycol based antifreeze liquids (if the mixtures are prepared perfectly).
- An aqueous solution must be made with potential pollution class of water 2 (EN 1717:2002 or local standards in force).



Follow the supplier's instructions for the life cycle duration and possible disposal of the antifreeze liquid.

Minimum temperature -15°C

In the previously listed conditions and with the addition of the antifreeze kit, the appliance is protected against freezing up to a temperature of -15°C.

Protect the domestic hot water circuit against freezing by using an accessory that is supplied on request (antifreeze kit) comprising two electric heating elements, the relevant wiring and a control thermostat (carefully read the installation instructions contained in the accessory kit pack).

Appliance antifreeze protection is thus only ensured if:

- the appliance is correctly connected to gas and electricity power supply circuits;
- the appliance is powered constantly;
- the appliance is not in "off" mode.
- the appliance is not in anomaly conditions (Parag. 2.5);
- the appliance essential components are not faulty.

The warranty does not cover damage due to interruption of the electrical power supply and failure to comply with that stated on the previous pages.



When installing the appliance in locations where the temperature falls below -5°C, insulation of the connection pipes, both DHW and CH, of the condensate drain pipe and the installation of the antifreeze kit is required, respecting all the conditions listed above.



The antifreeze systems described in this chapter are only to protect the appliance; the presence of these functions and devices does not exclude the possibility of parts of the system or domestic hot water circuit outside the appliance from freezing.

1.5 INSTALLATION INSIDE THE RECESSED FRAME (OPTIONAL)

The appliance is designed for installation inside the Immergas recessed frame (supplied as optional).
The necessary parts for this type of installation (brackets) must also be purchased separately as optional kit.
To install proceed as follows:

- Install the bracket (2) inside the recessed frame fixing it with the screws (3) in the pre-drilled holes (Fig. 4).
- Hang the boiler (4) to the bracket (2) (Fig. 5).
- Block the boiler (4) by mounting the brackets (5) and fixing them with their screws (6) (Fig. 6).

The brackets (5) used to centre the appliance on the frame and hold it in place stop against the frame (1) so do not require fixing to the frame itself.

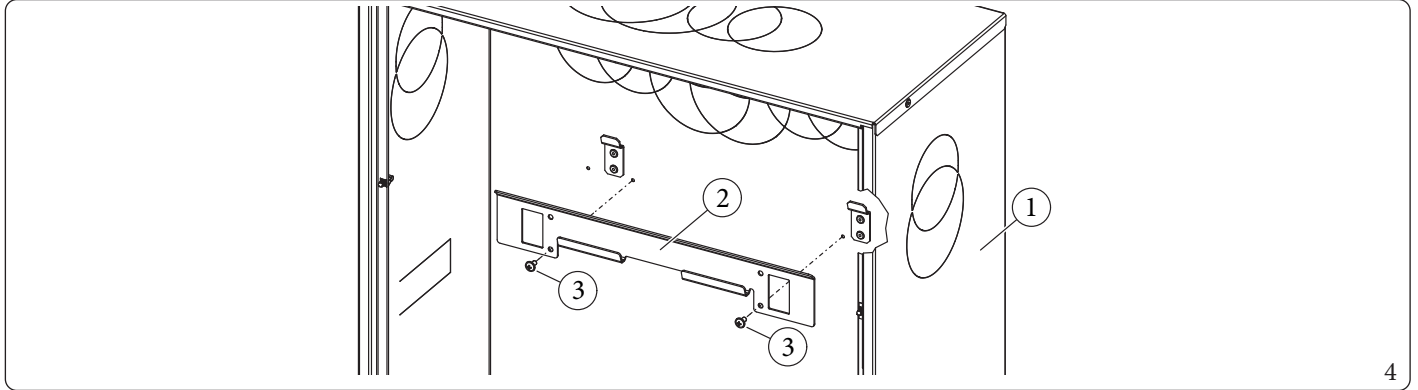

4

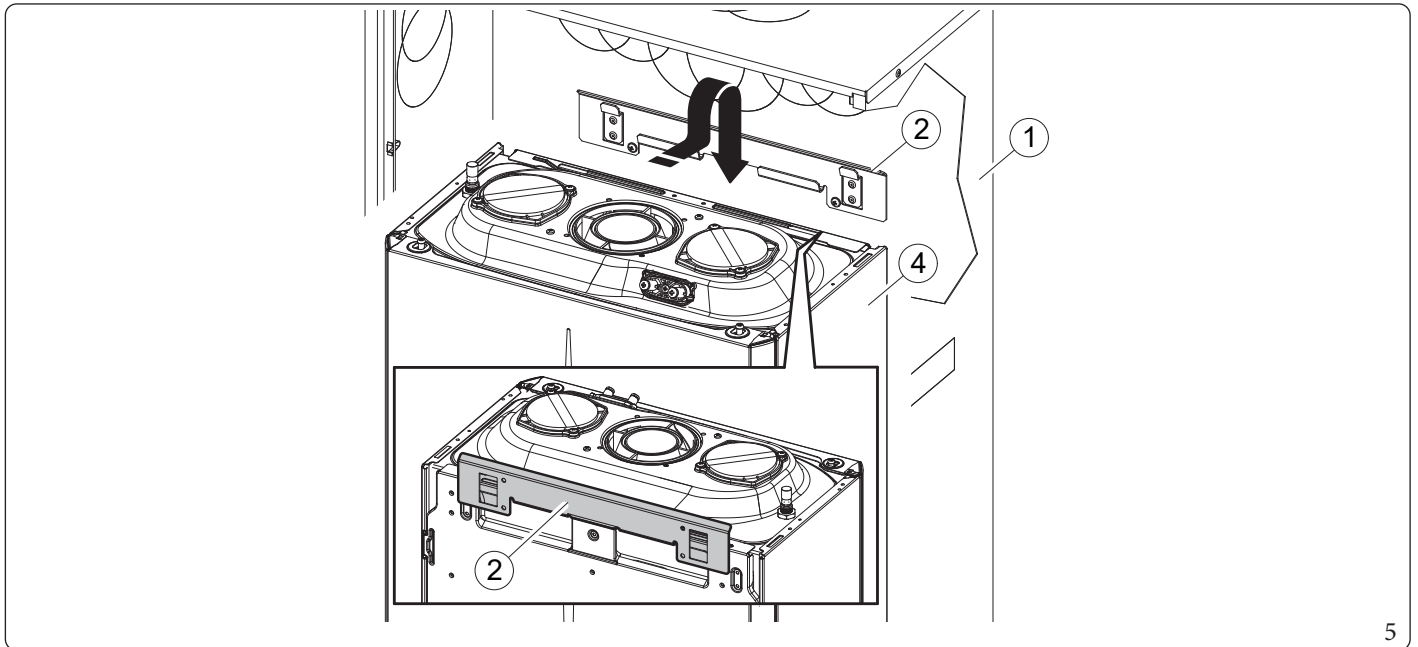

5

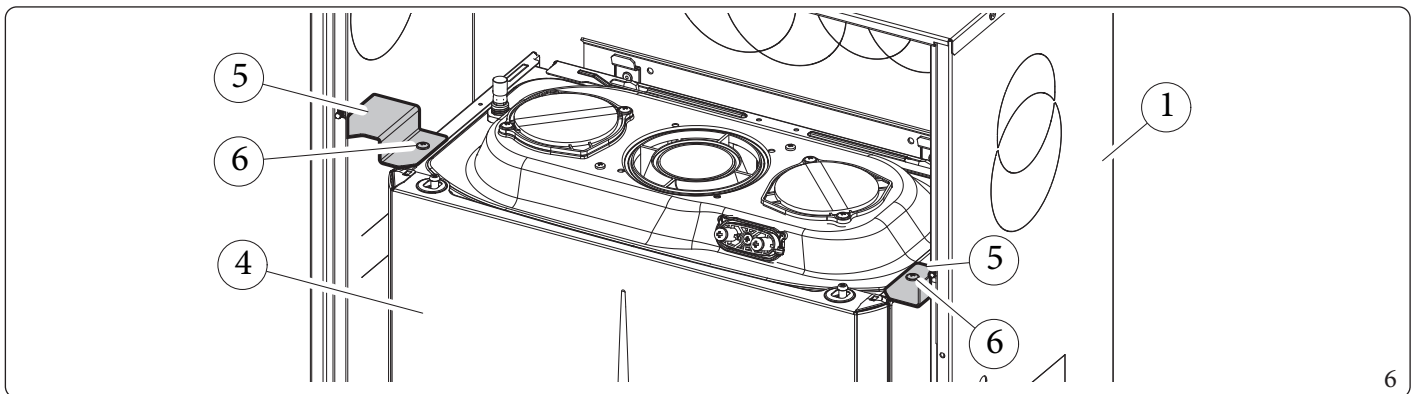

6

INSTALLER

USER

MAINTENANCE TECHNICIAN

TECHNICAL DATA

1.6 APPLIANCE CONNECTION UNIT

The connection unit consisting of all the necessary parts to perform the hydraulic and gas system connections of the appliance comes as optional kit. Perform the connections respecting the layout based on the type of installation to be made (Fig. 7):

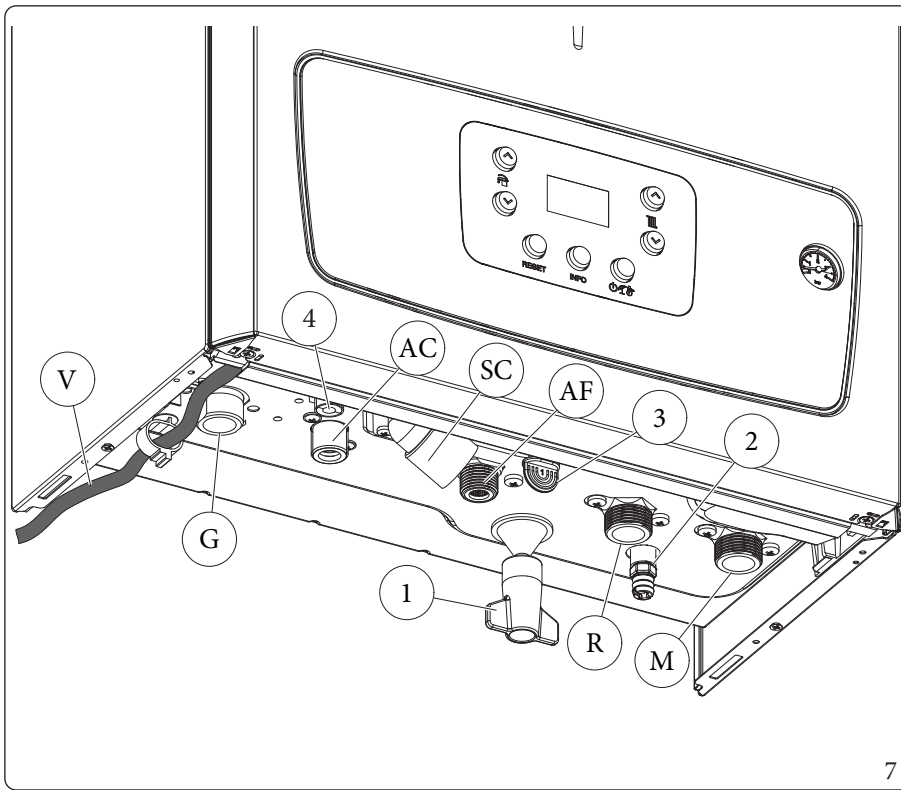

Key (Fig. 7):

- V - Electrical connection
 - G - Gas supply
 - AC - Domestic hot water outlet
 - AF - Domestic hot water inlet
 - SC - Condensate drain (minimum internal diameter Ø 13 mm)
 - M - System flow
 - R - System return
-
- 1 - System filling valve
 - 2 - System draining valve
 - 3 - 3 bar safety valve drain fittings signal
 - 4 - Air vent valve drain

1.7 GAS CONNECTION

Our appliances are built to work with natural gas (G20), LPG and mixtures of methane and hydrogen up to 20% in volume (20% H2NG). Power supply pipes must be the same as or larger than the appliance fitting.

Data nameplate positioning

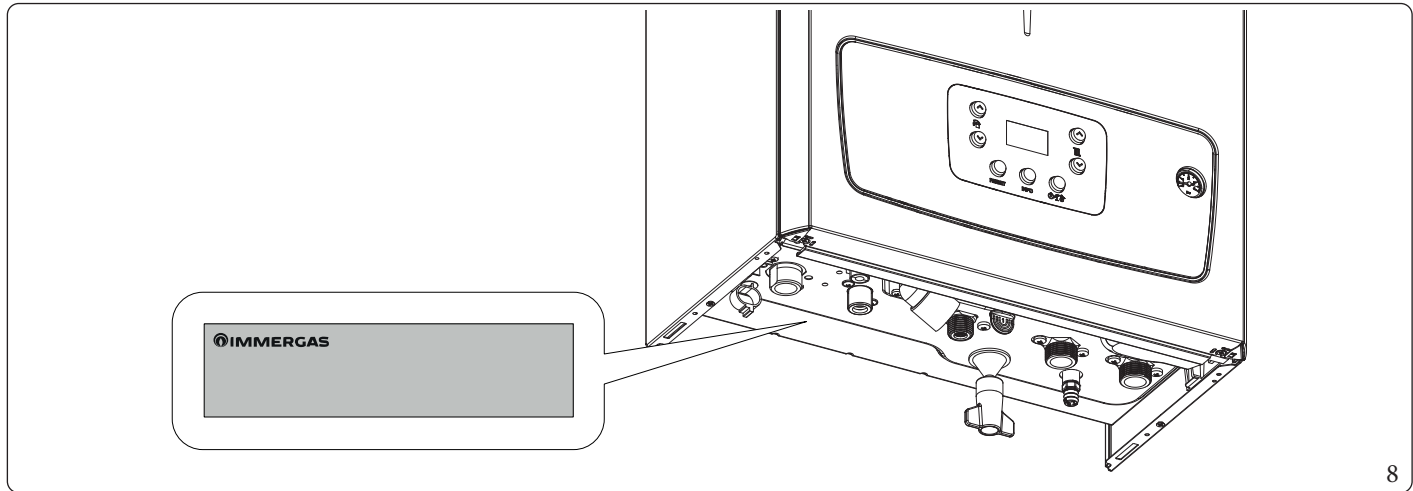

! Before connecting the gas line, carefully clean inside all the fuel feed system pipes to remove any residue that could impair appliance efficiency.
Also make sure the gas corresponds to that for which the appliance is prepared (see appliance data nameplate).
If different, the boiler must be converted for operation with the other type of gas (see converting appliance for other gas types).

! **It is also important to check the dynamic pressure of the mains (methane or LPG) used to supply the boiler, which must comply with EN 437 and its attachment, as insufficient levels may reduce generator output and cause discomfort to the user.**
Static/dynamic network pressures higher than those required for regular operation may cause serious damage to the appliance control elements; in this case shut the gas line off.
Do not operate the device.
Have the device checked by experienced personnel.

! According to the local regulation in force, make sure that a gas cock is installed upstream of each connection between the appliance and the gas system. This cock, if supplied by the appliance's manufacturer, can be directly connected to the appliance (i.e. downstream from the pipes connecting the system to the appliance), according to the manufacturer's instructions.
The Immergas connection unit, supplied as an optional kit, also includes the gas cock, whose installation instructions are provided in the kit.
In any case, make sure the gas cock is connected properly.

The gas supply pipe must be suitably dimensioned according to current regulations in order to guarantee correct gas flow rate to the burner even in conditions of maximum generator output and to guarantee appliance efficiency (technical specifications).
The coupling system must conform to standards in force (EN 1775).

! The appliance is designed to operate with fuel gas free from impurities; otherwise it is advisable to fit special filters upstream of the appliance to restore the purity of the fuel.

Storage tanks (in case of supply from LPG depot).

- New LPG storage tanks may contain residual inert gases (nitrogen) that degrade the mixture delivered to the appliance causing functioning anomalies.
- Due to the composition of the LPG mixture, layering of the mixture components may occur during the period of storage in the tanks. This can cause a variation in the calorific value of the mixture delivered to the appliance, with subsequent change in its performance.

1.8 HYDRAULIC CONNECTION



In order not to void the condensation module warranty before making the boiler connections, carefully clean the heating system (pipes, radiators, etc.) with special pickling or descaling products to remove any deposits that could compromise correct boiler operation.

A treatment of the heating and water system water is required, in compliance with the technical standards in force, in order to protect the system and the appliance from deposits (e.g. scale), slurry or other hazardous deposits.

In order not to void the heat exchanger warranty, you are required to comply with what has been prescribed in (Par. 1.24).

Hydraulic connections must be made in a rational way using the couplings on the appliance template.



The manufacturer declines all liability in the event of damage caused by the installation of an automatic filling system.

In order to meet the system requirements established by EN 1717 in terms of pollution of drinking water, we recommend installing the IMMERGAS anti-backflow kit to be used upstream of the cold water inlet connection of the appliance. We also recommend using category 2 heat transfer fluid (e.g.: water+ glycol) in the appliance's primary circuit (C.H. circuit), as defined in standard EN 1717.



To preserve the duration of appliance efficiency features, in the presence of water whose features can lead to the deposit of lime scale, installation of the "polyphosphate dispenser" kit is recommended.

3 bar safety valve

Discharge of the safety valve has been conveyed to the condensate drain trap outlet. Consequently, in the event of valve intervention, the discharged liquid will end up in the sewer system through the drain pipe of the condensate drain trap.

In any case, the lower part of the appliance is fitted with a drain fitting (Ref. 3 Fig. 7) with the relative closure cap to check for the presence of liquid in the discharge circuit and to check the intervention of the 3 bar safety valve.

Condensate drain

To drain the condensate produced by the appliance, it is necessary to connect to the drainage system by means of acid condensate resistant pipes, with an internal Ø of at least 13 mm.

The system connecting the appliance to the drainage system must be carried out in such a way as to prevent occlusion and freezing of the liquid contained in it.

Before appliance ignition, ensure that the condensate can be correctly removed. After first ignition, check that the drain trap is filled with condensate (Parag. 1.26 Filling the condensate drain trap).

Also, comply with national and local regulations on discharging waste waters.

In the event condensate is not discharged into the wastewater drainage system, a condensate neutraliser must be installed to ensure compliance with the parameters established by the legislation in force.

1.9 ELECTRICAL CONNECTION

The appliance has an IPX5D protection degree; electrical safety of the appliance is achieved only when it is connected properly to an efficient earthing system, as specified by current safety standards.



The manufacturer declines any responsibility for damage or physical injury caused by failure to connect the appliance to an efficient earthing system or failure to comply with the IEC reference standards.



Open the control panel connections compartment (Fig. 9).

To carry out electrical connections, all you have to do is open the connections compartment as follows.

1. Remove the front casing (Fig. 56).
2. Disassemble the cover (a).
3. Press the two hooks on the connections compartment cover.
4. Remove the cover (a) from the control panel (b).

At this point, it is possible to access the terminal board (c).



The compartment (d) has cable clamps and screws to be used for connection of the optional external connections.

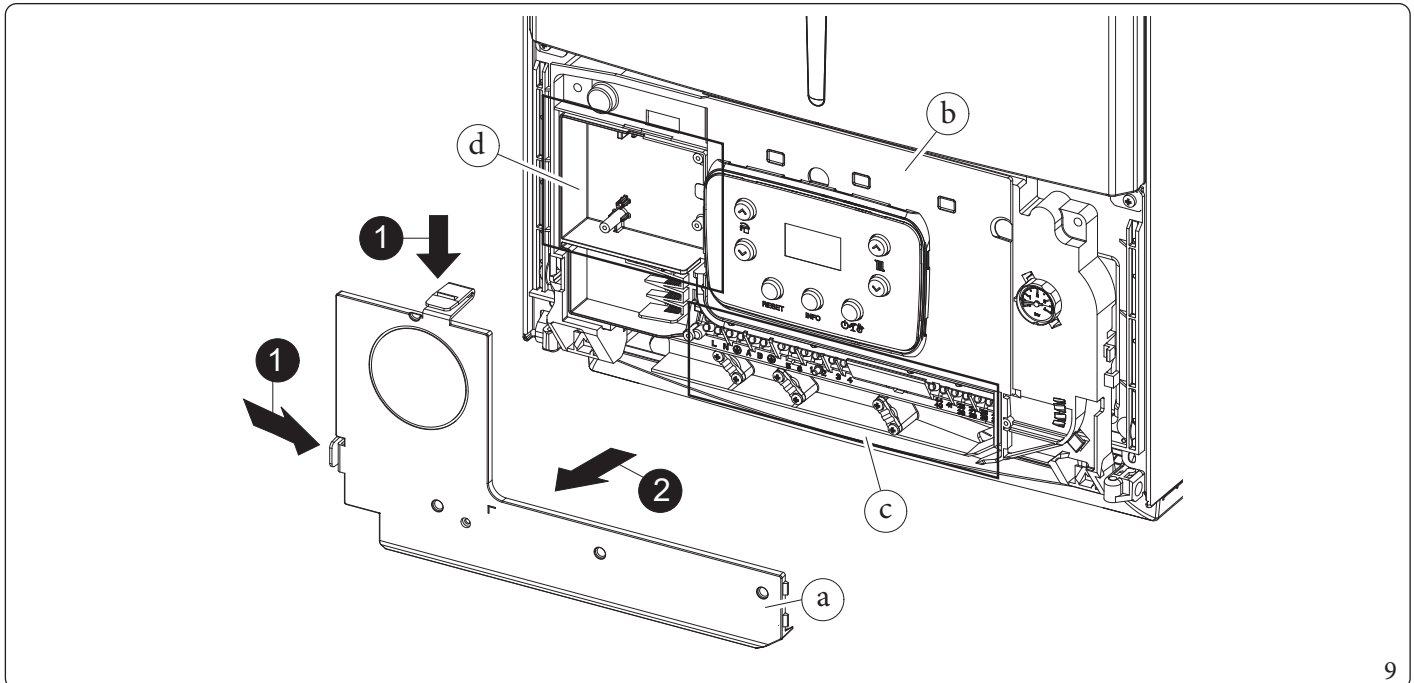

Also ensure that the electrical installation corresponds to maximum absorbed power specifications as shown on the appliance data nameplate.

Boilers are supplied complete with a special "X" type power cable without plug.



The power supply cable must be connected to a 230V \pm 10% / 50Hz mains supply respecting L-N polarity and earth connection; this network must also have a multi-pole circuit breaker with class III overvoltage category in compliance with installation regulations.



To protect from possible dispersions of DC voltage, it is necessary to provide a type A differential safety device.



If the power supply cable is damaged, it must be replaced by a special cable or assembly, which are only available from the manufacturer or its Authorised After-Sales Technical Assistance Centre.



It is recommended to contact a qualified company (e.g. the Authorised After-Sales Technical Assistance Centre) for replacement to avoid a hazard.

The power cable must be laid as shown (Fig. 7).

If the network fuse indicated in the wiring diagram (Fig. 41) as component "F1" on the P.C.B. needs to be changed, this operation must also be performed by qualified personnel using a 3.15A rapid type (F) 250VAC fuse (dimension 5 x 20).

For the main power supply to the appliance, never use adapters, multiple sockets or extension leads.

Installation with system operating at direct low temperature.

The boiler can directly supply a low temperature system by setting the flow temperature adjustment range "t0" and "t1" (Par. 3.11).

In this situation it is good practice to insert a relevant safety kit (optional) made up from a thermostat (with adjustable temperature).

The thermostat must be positioned on the system flow pipe at a distance of at least 2 metres from the boiler.

1.10 REMOTE CONTROLS AND ROOM CHRONO-THERMOSTATS (OPTIONAL)

The appliance is set up for room chrono-thermostats or remote controls, available as optional kits.

All Immergas chrono-thermostats are connected with 2 wires only.

Carefully read the user and assembly instructions contained in the accessory kit.



Disconnect power to the unit before making any electrical connections.

On/Off Immergas digital chrono-thermostat.

The chrono-thermostat allows:

- set two room temperature value: one for day (comfort temperature) and one for night (reduced temperature);
- set a weekly programme with four daily switch on and switch off times;
- selecting the required function mode from the various possible alternatives:
 - manual mode (with adjustable temperature);
 - automatic mode (with set programme);
 - forced automatic operation (momentarily changing the temperature of the automatic program).

The chrono-thermostat is powered by two 1.5V LR6 type alkaline batteries.

“Comando Amico Remoto” (Remote Control Device) ^{V2} (CAR^{V2}) with climate chrono-thermostat function.

In addition to the functions described in the previous point, the CAR^{V2} panel enables the user to control all the important information regarding operation of the appliance and the heating system with the opportunity to easily intervene on the previously set parameters, without having to go to where the appliance is installed.

The panel is equipped with self-diagnosis to show any appliance operating anomalies on the display.

The climate chrono-thermostat incorporated into the remote panel enables the system flow temperature to be adjusted to the actual needs of the room being heated, in order to obtain the desired room temperature with extreme precision and therefore with evident saving in running costs.

The CAR^{V2} is fed directly by the appliance by means of the same 2 wires used for the transmission of data between the appliance and device.

“Comando Amico Remoto” (Remote Control Device) ^{V2} or On/Off chrono-thermostat electrical connection (Optional).



The operations described below must be performed after having removed the voltage from the appliance.

Any thermostat or On/Off environment chrono-thermostat must be connected to clamps 44/40 and 41 eliminating jumper X40 (Fig. 41). Make sure that the On/Off thermostat contact is of the “clean” type, i.e. independent of the mains voltage, otherwise the P.C.B. would be damaged.

Any Comando Amico Remoto remote control ^{V2} must be connected to terminals 44/40 and 41, eliminating jumper X40 on the P.C.B. (Fig. 41).

The boiler can only be connected to one remote control.



If the Comando Amico Remoto remote control ^{V2} or any other On/Off chrono-thermostat is used arrange two separate lines in compliance with current regulations regarding electrical systems.

No appliance pipes must ever be used to earth the electric system or telephone lines.

Ensure elimination of this risk before making the appliance electrical connections.

1.11 EXTERNAL TEMPERATURE PROBE (OPTIONAL)

The appliance is prepared for the application of the external probe (Fig. 10), which is available as an optional kit.

Refer to the relative instruction sheet for positioning of the external probe.

The probe can be connected directly to the appliance electrical system and allows the max. system flow temperature to be automatically decreased when the external temperature increases, in order to adjust the heat supplied to the system according to the change in external temperature.

The external probe always operates when connected, regardless of the presence or type of room chrono-thermostat used and can work in combination with Immergas chrono-thermostats.

The correlation between system flow temperature and external temperature is determined by the position of the central heating selector switch on the device control panel (or on the CA^{V2} control panel if connected to the boiler) according to the curves shown in the diagram (Fig.11).

The electric connection of the external probe must be made on terminals 38 and 39 on the terminal board on the appliance control panel (Fig. 41).

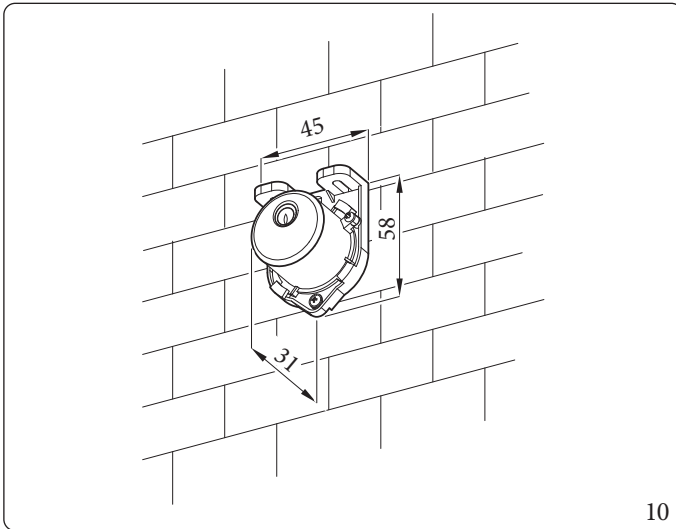

Correction law of the flow temperature depending on the external temperature and user adjustment of the central heating temperature.

* Position of the central heating temperature control.

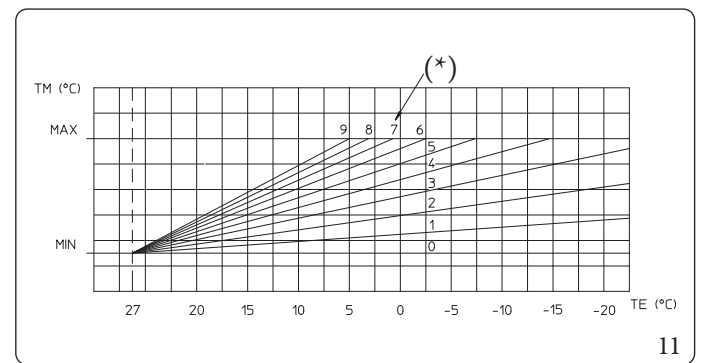

1.12 IMMERGAS FLUE SYSTEMS

Immergas supplies various solutions separately from the appliances regarding the installation of air intake terminals and flue extraction, which are fundamental for appliance operation.



The appliance must be installed with an original Immergas "Green Range" inspectionable air intake system and flue gas extraction system made of plastic, with the exception of configuration C₆, as required by the regulations in force and by the product's approval. This flue can be identified by an identification mark and special distinctive marking bearing the note "only for condensation boilers".

For non-original flue system, refer to the technical data of the appliance.



The plastic pipes cannot be installed outdoors, for tracts longer than 40 cm, without suitable protection from UV rays and other atmospheric agents.

Resistance factors and equivalent lengths

Each flue component has a Resistance Factor based on experimental tests and specified in the table in Paragraph 1.13..

The Resistance Factor for individual components is independent from the type of appliance on which it is installed and has a dimensionless size.

It is however, conditioned by the temperature of the fluids that pass through the pipe and therefore, varies according to applications for air intake or flue exhaust.

Each single component has a resistance corresponding to a certain length in metres of pipe of the same diameter; the so-called equivalent length, can be obtained from the ratio between the relative Resistance Factors.

All devices have an experimentally obtainable maximum Resistance Factor equal to 100.

The maximum Resistance Factor allowed corresponds to the resistance encountered with the maximum allowed pipe length for each type of Terminal Kit.

This information allows calculations to be made to verify the possibility of setting up various flue configurations.



To dimension the flue ducting using commercial components, refer to the table of combustion parameters (Par. 4.2).

Positioning the gaskets (black) for “green range” flue systems.

Position the gasket correctly (for bends and extensions) (Fig. 12):

- gasket (A) with notches, to use for bends;
- gasket (B) without notches, to use for extensions.

If necessary, to ease the push-fitting, spread the elements with commonly-used talc.

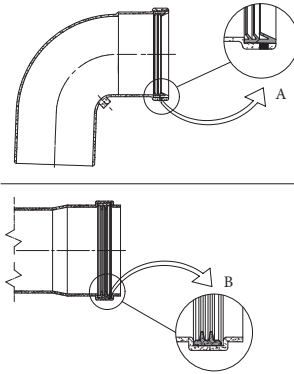

12

Extension pipes and concentric elbows push-fittings.

To install push-fitting extensions with other elements of the flue, proceed as follows:

- Install the concentric pipe or elbow with the male side (smooth) on the female side (with lip seal) to the end stop on the previously installed element in order to ensure sealing efficiency of the coupling.



If the exhaust terminal and/or extension concentric pipe needs shortening, consider that the internal duct must always protrude by 5 mm with respect to the external duct.



For safety purposes, do not even temporarily obstruct the appliance intake/exhaust terminal. The various parts of the flue system must be checked to ensure that they have been laid in such a way as to prevent the coupled parts from detaching, in particular, the flue exhaust duct in the Ø80 separator kit configuration. If the condition described above is not adequately guaranteed, it will be necessary to use the appropriate retaining clamp kit.







When installing horizontal pipes, a minimum inclination of 5% towards the appliance must be maintained, and a section clamp with plug must be installed every 3 metres.

Installation inside the recessed frame

In this mode, install the flue according to your needs using the appropriate pre-sections in the frame to exit from its clearances.

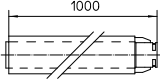
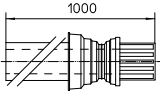
1.13 TABLES OF RESISTANCE FACTORS AND EQUIVALENT LENGTHS OF “GREEN RANGE” FLUE SYSTEM COMPONENTS











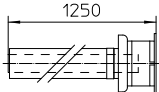

TYPE OF DUCT		Resistance Factor (R)	Equivalent length in m of concentric pipe Ø 80/125
Concentric pipe 80/125 Ø m 1		2,1	1
90° concentric bend 80/125 Ø		3,0	1,4
Concentric bend 45° Ø 80/125		2,1	1
Terminal complete with concentric horizontal intake-exhaust Ø 80/125		2,8	1,3
Terminal complete with concentric vertical intake-exhaust Ø 80/125		3,6	1,7
90° concentric bend Ø 80/125 with inspection		3,4	1,6
Stub pipe with inspection Ø 80/125		3,4	1,6

INSTALLER

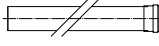
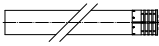
USER

MAINTENANCE TECHNICIAN

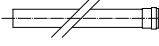
TECHNICAL DATA

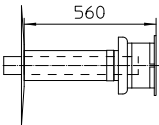
TYPE OF DUCT		Resistance factor (R)	Equivalent length in m of concentric pipe Ø 60/100	Equivalent length in m of pipe Ø 80	Equivalent length in m of pipe Ø 60	Equivalent length in m of concentric pipe Ø 80/125
Concentric pipe Ø 60/100 m 1		Intake m 6.4	m 1	Intake m 7.3	Exhaust m 1.9	m 3,0
		Exhaust m 6.4		Exhaust m 5.3		
90° concentric bend Ø 60/100		Intake m 8.2	m 1,3	Intake m 9.4	Exhaust m 2.5	m 3,9
		Exhaust m 8.2		Exhaust m 6.8		
45° concentric bend Ø 60/100		Intake m 6.4	m 1	Intake m 7.3	Exhaust m 1.9	m 3,0
		Exhaust m 6.4		Exhaust m 5.3		
Terminal complete with concentric horizontal intake-exhaust Ø 60/100		Intake m 15	m 2,3	Intake m 17.2	Exhaust m 4.5	m 7,1
		Exhaust m 15		Exhaust m 12.5		
Concentric horizontal intake-exhaust terminal Ø 60/100		Intake m 10	m 1,5	Intake m 11.5	Exhaust m 3.0	m 4,7
		Exhaust m 10		Exhaust m 8.3		
Terminal complete with concentric vertical intake-exhaust Ø 60/100		Intake m 16.3	m 2,5	Intake m 18.7	Exhaust m 4.9	m 7,7
		Exhaust m 16.3		Exhaust m 13.6		
Concentric vertical intake-exhaust terminal Ø 60/100		Intake m 9	m 1,4	Intake m 10.3	Exhaust m 2.7	m 4,3
		Exhaust m 9		Exhaust m 7.5		
Pipe Ø 80 m 1		Intake m 0.87	m 0,1	Intake m 1.0	Exhaust m 0.4	m 0,4
		Exhaust m 1.2	m 0,2	Exhaust m 1.0		m 0,5
Complete intake terminal Ø 80 m 1		Intake m 3	m 0,5	Intake m 3.4	Exhaust m 0.9	m 1,4
Intake terminal Ø 80 Exhaust terminal Ø 80		Intake m 2.2	m 0,35	Intake m 2.5	Exhaust m 0.6	m 1
		Exhaust m 1.9	m 0,3	Exhaust m 1.6		m 0,9
90° bend Ø 80		Intake m 1.9	m 0,3	Intake m 2.2	Exhaust m 0.8	m 0,9
		Exhaust m 2.6	m 0,4	Exhaust m 2.1		m 1,2
45° bend Ø 80		Intake m 1.2	m 0,2	Intake m 1.4	Exhaust m 0.5	m 0,5
		Exhaust m 1.6	m 0,25	Exhaust m 1.3		m 0,7
Pipe Ø 60 m 1 for ducting		Exhaust m 3.3	m 0,5	Intake m 3.8	Exhaust m 1.0	m 1,5
				Exhaust m 2.7		
90° bend Ø 60 for ducting		Exhaust m 3.5	m 0,55	Intake m 4.0	Exhaust m 1.1	m 1,6
				Exhaust m 2.9		
Reduction Ø 80/60		Intake m 2.6	m 0,4	Intake m 3	Exhaust m 0.8	m 1,2
		Exhaust m 2.6		Exhaust m 2.1		
Terminal complete with vertical exhaust Ø 60 for piping		Exhaust m 12.2	m 1,9	Intake m 14	Exhaust m 3.7	m 5,8
				Exhaust m 10.1		

1.14 OUTDOOR INSTALLATION IN PARTIALLY PROTECTED AREA



By partially protected area, we mean one in which the unit is not directly exposed to the elements (rain, snow, hail, etc.).



If the appliance is installed in a location where the ambient temperature falls below -5°C , use the optional antifreeze kit, checking the ambient temperature range for operation in the technical data table in this instruction manual (Section 'Technical Data').



This type of installation is possible when permitted by the laws in force in the appliance's country of destination.

Configuration type B, open chamber and fan assisted (B_{23} or B_{53}).

Using the relevant cover kit, direct air intake is possible and flue gas is exhausted into a single flue or directly to the outside. In this configuration it is possible to install the appliance in a partially protected place. In this configuration the appliance is classified as type B.

With this configuration:

- air intake takes place directly from the room in which the appliance is installed;
- the flue gas exhaust must be connected to its own single chimney (B_{23}) or ducted directly outside via a vertical terminal for direct exhaust (B_{53}) or via an Immergas ducting system (B_{53}).

The technical regulations in force must be respected.

Cover kit assembly (Fig. 14).

Remove the two plugs from the two lateral intake holes.

Install the $\varnothing 80$ outlet flange on the central hole of the boiler, taking care to insert the gasket supplied with the kit and tighten by means of the screws provided.

Install the upper cover, fixing it using the 4 screws present in the kit, positioning the relevant gaskets.

Max. length of exhaust duct.

The flue pipe (both vertical or horizontal) can be extended to a max. length of 30 linear metres.

Coupling of extension pipes.

To install push-fitting extensions with other elements of the flue, proceed as follows: Couple the pipe or elbow with the male side (smooth) in the female side (with lip seal) to the end stop on the previously installed element. This will ensure sealing efficiency of the coupling.

Engage the 90° $\varnothing 80$ bend with the male end (smooth) in the female end (with lip seal) of the $\varnothing 80$ flange unit to the end stop. Introduce the gasket, making it run along the bend. Fix it using the metal sheet plate and tighten by means of the clips present in the kit, making sure to block the 4 gasket flaps.

Fit the male end (smooth) of the exhaust pipe into the female end of the 90° $\varnothing 80$ bend, making sure that the relevant wall sealing plate is already fitted; this will ensure hold and joining of the elements making up the kit.

Configuration without cover kit in a partially protected location (type C appliance).

By leaving the intake plug fitted it is possible to install the appliance externally without the cover kit.

Installation takes place using the $\varnothing 60/100$ and $\varnothing 80/125$ concentric intake/ exhaust kits. Refer to the paragraph on indoor installation.

In this configuration the Top cover kit guarantees an additional protection for the boiler. It is recommended with $\varnothing 60/100$ concentric and it is mandatory with $\varnothing 80$ exhaust.

The $\varnothing 80/80$ separating device cannot be used in this configuration (coupled with the cover kit).

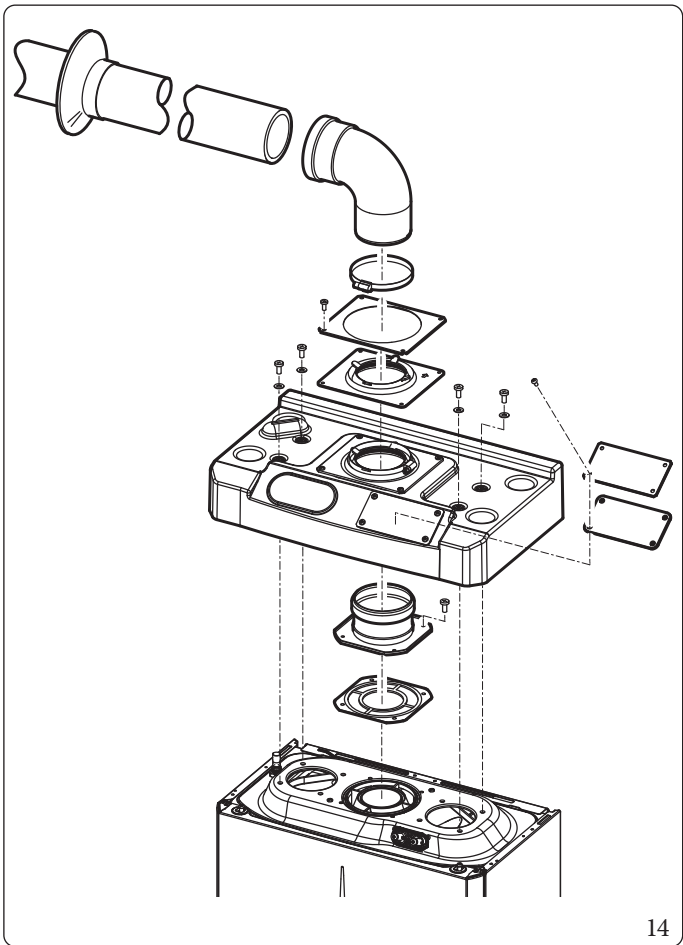
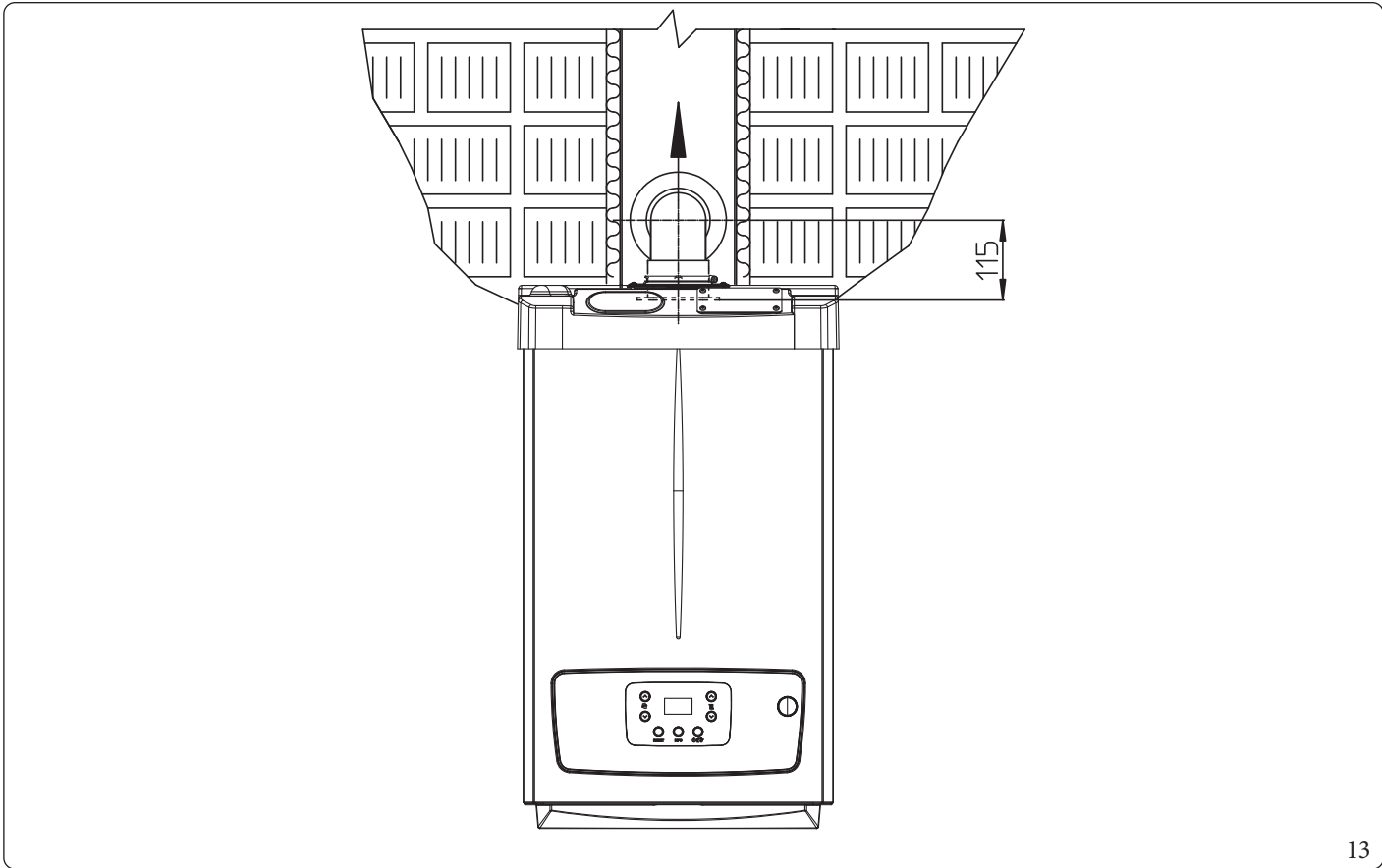

The cover kit includes (Fig. 14):

- N°1 Thermoformed cover
- N°1 Gasket clamping plate
- N°1 Gasket
- N°1 Gasket tightening clip

The terminal kit includes (Fig. 14):

- N°1 Gasket
- N°1 Exhaust flange Ø 80
- N°1 Ø 80 90° bend
- N°1 Exhaust pipe Ø 80
- N°1 Wall sealing plate

1.15 INTERNAL INSTALLATION USING A RECESSED FRAME WITH DIRECT AIR INTAKE

Configuration type B, open chamber and fan assisted

In this configuration the appliance is classified as type B₂₃.

Using a kit separator, one can achieve direct air intake (Fig. 15) and flue exhaust in a single chimney or directly outside.

With this configuration:

- air intake takes place directly from the environment in which the appliance is installed and only functions in permanently ventilated rooms;
- the flue gas exhaust must be connected to its own individual chimney and channelled directly into the external atmosphere.

The technical regulations in force must be respected.

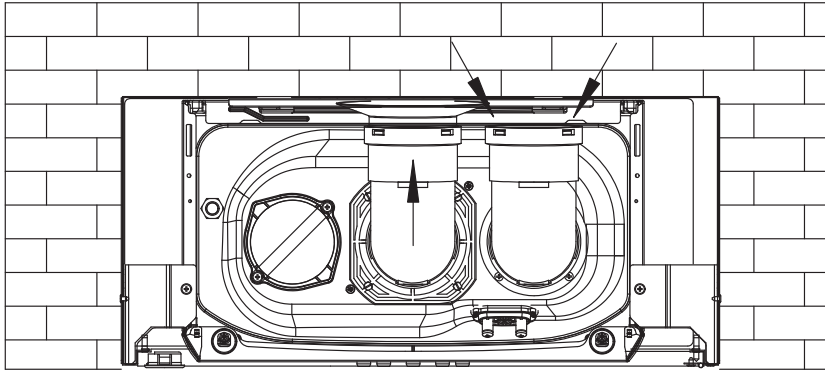

15

Separator kit installation (Fig. 16).

1. Install the discharge flange on the central hole of the boiler, positioning the relative gasket with the circular projections downwards in contact with the boiler flange, and tighten using the hex screws with flat tip contained in the kit.
2. Remove the flat flange present in the lateral hole with respect to the central one (according to needs) and replace it with the intake flange, positioning its gasket already present in the boiler and tighten using the supplied self-threading screws.
3. Fit the bends with male side (smooth) in the female side of the flanges (the intake bend should face the rear side of the boiler).
4. Fit the exhaust pipe with the male side (smooth) to the female side of the bend up to the end stop, making sure that the internal wall sealing plate has been fitted and connecting the required flue according to personal requirements.

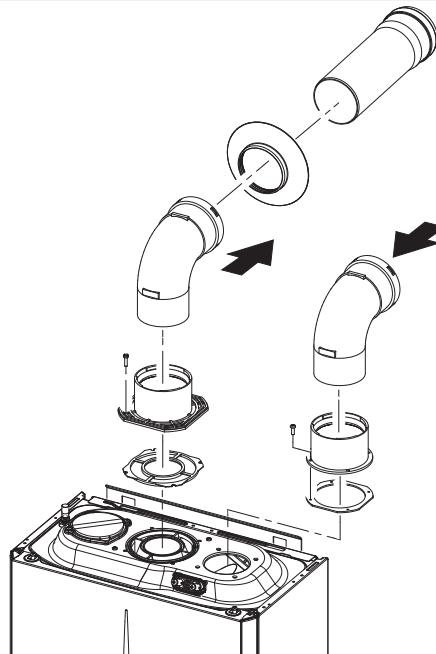

16

Max. length of exhaust duct.

The flue pipe (both vertical or horizontal) can be extended to a max. length of 36 linear metres.

1.16 CONCENTRIC HORIZONTAL KIT INSTALLATION

Type C configuration, sealed chamber and fan assisted

The position of the terminal (in terms of distances from openings, overlooking buildings, floor, etc.) must be in compliance with the regulations in force.

This terminal is connected directly to the outside of the building for air intake and flue gas exhaust.

The horizontal kit can be installed with the rear, right side, left side or front outlet.

For installation with frontal outlet, one must use the fixing plate and a concentric bend coupling in order to ensure sufficient space to carry out the tests required by law upon commissioning.

External grid

Both the $\varnothing 60/100$ and $\varnothing 80/125$ intake/exhaust terminal, if properly installed, is pleasant to look at on the outside of the building.

Make sure that the external silicone wall sealing plate is properly inserted in the wall.



For correct functioning of the system the terminal with grid must be installed correctly ensuring that, the "high" indication present on the terminal is respected on installation.

Installation of horizontal intake/exhaust kit $\varnothing 60/100$ (Fig. 17)

1. Install the curve with flange (2) on the central hole of the appliance, positioning gasket (1) with the circular projections downwards in contact with the appliance flange, and tighten using the screws contained in the kit.
2. Fit the $\varnothing 60/100$ (3) concentric terminal pipe with the male side (smooth) to the female side of the bend (2) up to the end stop, making sure that the internal and external wall sealing plates have been fitted; this will ensure sealing and joining of the elements making up the kit.

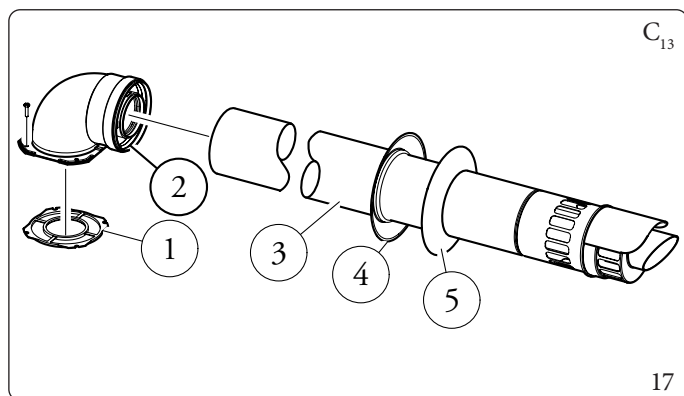

The kit includes (Fig. 17):

- N°1 Gasket (1)
- N°1 Concentric bend $\varnothing 60/100$ (2)
- N°1 Int./exhaust concentric terminal $\varnothing 60/100$ (3)
- N°1 Internal wall sealing plate (4)
- N°1 External wall sealing plate (5)

Extensions for $\varnothing 60/100$ horizontal kit. Kit assembly (Fig. 18)

The kit with this configuration can be extended up to a max. horizontal length of 12.9 m including the terminal with grid and excluding the concentric bend leaving the appliance.

In this case the special extensions must be requested.

Immergas also provides a $\varnothing 60/100$ simplified terminal, which in combination with its extension kits allows you to reach a maximum extension of 11.9 metres.

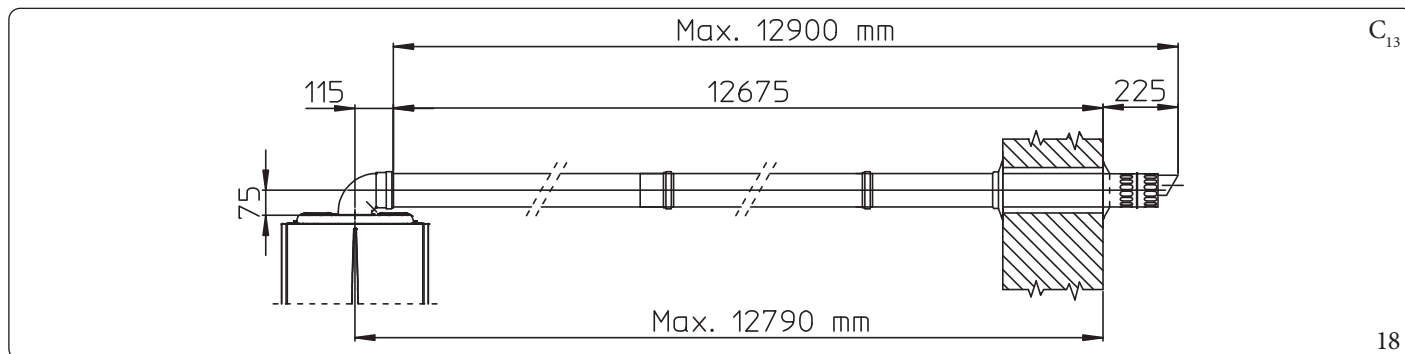

Installation of horizontal intake/exhaust kit Ø 80/125 (Fig. 19)

To install the kit Ø 80/125 one must use the flanged adapter kit in order to install the flue system Ø 80/125.

1. Install the flanged adaptor (2) on the central hole of the appliance, positioning gasket (1) with the circular projections downwards in contact with the appliance flange, and tighten using the screws contained in the kit.
2. Engage the bend (3) with the male side (smooth) to the end stop on the adaptor (2).
3. Fit the Ø 80/125 (4) concentric terminal pipe with the male side (smooth) to the female side of the bend (3) (with lip seals) up to the end stop, making sure that the internal (5) and external wall sealing plates (6) have been fitted; this will ensure sealing and joining of the elements making up the kit.

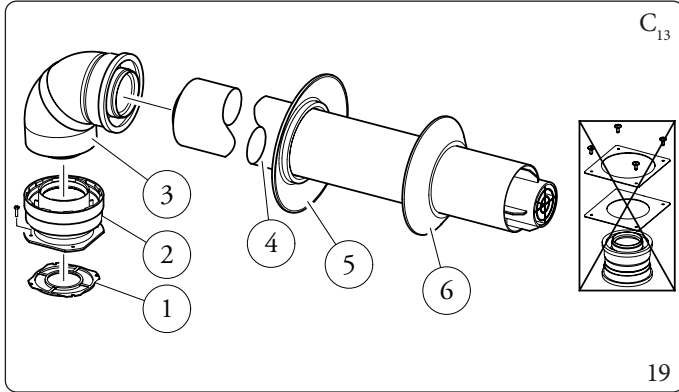

The adapter kit includes (Fig. 19):

- N°1 Gasket (1)
- N°1 Adapter Ø 80/125 (2)

The Ø 80/125 kit includes (Fig. 19):

- N°1 Concentric bend Ø 80/125 at 87° (3)
- N°1 Int./exhaust concentric terminal Ø 80/125 (4)
- N°1 Internal wall sealing plate (5)
- N°1 External wall sealing plate (6)

The remaining kit components must not be used

Extensions for Ø 80/125 horizontal kit. Kit assembly (Fig. 20)

The kit with this configuration can be extended up to a max. length of 32 m, including the terminal with grid and excluding the concentric bend leaving the appliance.

If additional components are assembled, the length equivalent to the maximum allowed must be subtracted.

In this case the special extensions must be requested.

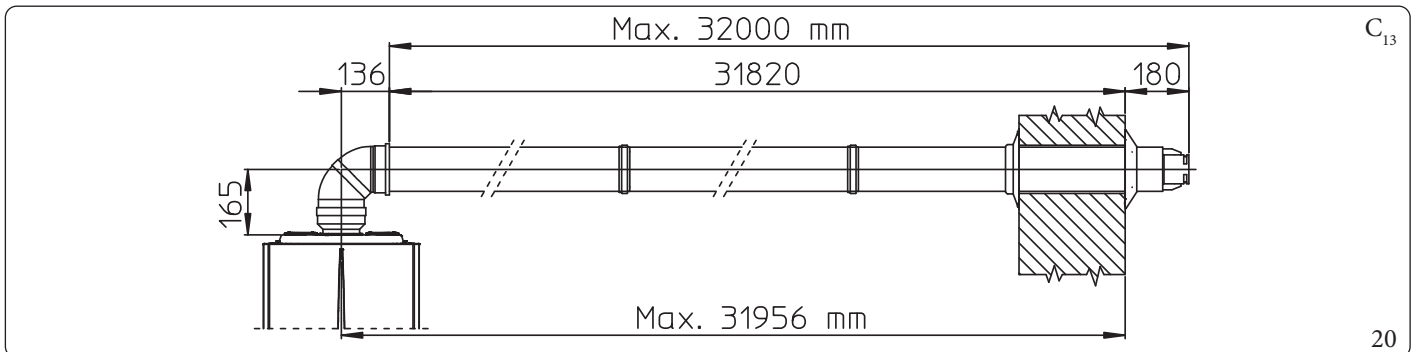

1.17 CONCENTRIC VERTICAL KIT INSTALLATION

Type C configuration, sealed chamber and fan assisted

Concentric vertical intake and exhaust kit.

This vertical terminal is connected directly to the outside of the building for air intake and flue gas exhaust.



The vertical kit with aluminium tile enables installation on terraces and roofs with a maximum slope of 45% (approx. 25°) and the height between the terminal cap and half-shell (374 mm for Ø 60/100 and 260 mm for Ø 80/125) must always be observed.

Vertical kit assembly with aluminium tile Ø 60/100 (Fig. 21)

1. Install the concentric flange (2) on the flue exhaust of the appliance, positioning gasket (1) with the circular projections downwards in contact with the appliance flange.
2. Tighten the concentric flange with the screws in the kit.
3. Replace the tiles with the aluminium sheet (4), shaping it to ensure that rainwater runs off.
4. Position the fixed half-shell (6) on the aluminium tile.
5. Insert the intake-exhaust pipe (5).
6. Fit the Ø 60/100 concentric terminal pipe with the male side (5) (smooth) into the flange (2) up to the end stop, making sure that the wall sealing plate has been fitted (3); this will ensure sealing and joining of the elements making up the kit.



When the appliance is installed in areas where very rigid temperatures can be reached, a special anti-freeze kit is available that can be installed as an alternative to the standard kit.

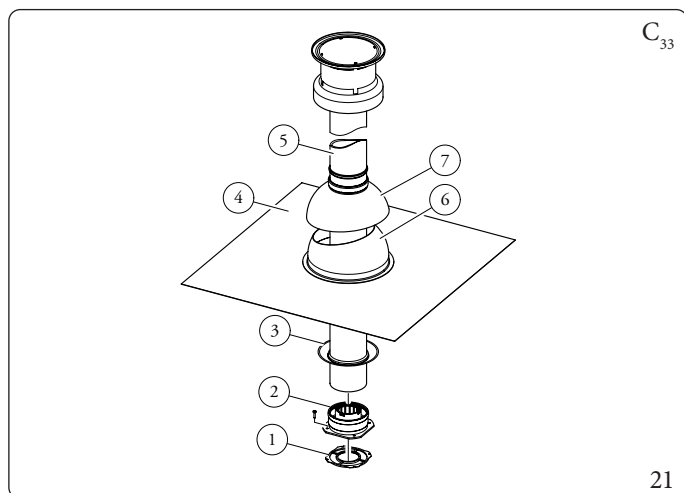

The kit includes (Fig. 21):

- N°1 Gasket (1)
- N°1 Female concentric flange (2)
- N°1 Wall sealing plate (3)
- N°1 Aluminium tile (4)
- N°1 Concentric intake/exhaust pipe Ø 60/100 (5)
- N°1 Fixed half-shell (6)
- N°1 Mobile half-shell (7)

Extensions for vertical kit Ø 60/100 (Fig. 22)

The kit with this configuration can be extended up to a max. vertical straight length of 14.4 m including the terminal. This configuration corresponds to a resistance factor of 100. In this case specific extensions must be requested.

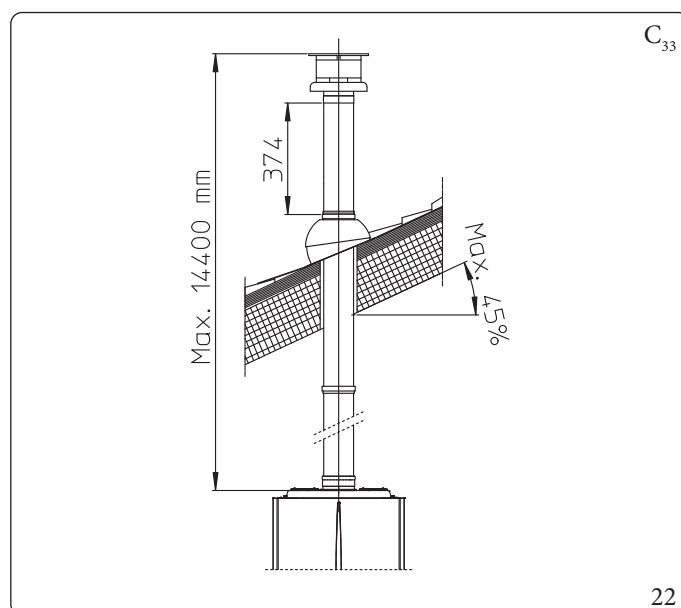

Vertical kit assembly with aluminium tile Ø 80/125 (Fig.23)

 To install the kit Ø 80/125 one must use the flanged adaptor kit in order to install the flue system Ø 80/125.

1. Install the flanged adaptor (2) on the central hole of the appliance, positioning gasket (1) with the circular projections downwards in contact with the appliance flange.

Imitation aluminium tile installation:

2. Tighten the concentric flange with the screws in the kit.
3. Replace the tiles with the aluminium sheet (4), shaping it to ensure that rainwater runs off.
4. Position the fixed half-shell (5) on the aluminium tile;
5. Insert the intake-exhaust terminal (7);
6. Fit the Ø 80/125 concentric terminal pipe with the male side (smooth) to the female side of the adapter (1) (with lip seals) up to the end stop, making sure that the wall sealing plate (3) has been fitted; this will ensure sealing and joining of the elements making up the kit.

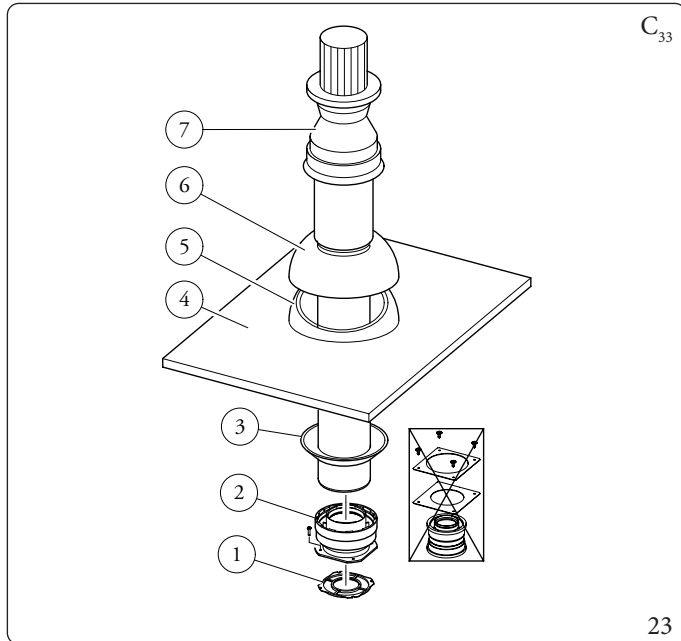

The adaptor kit includes (Fig. 23):

- N°1 Gasket (1)
- N°1 Adapter Ø 80/125 (2)

The Ø 80/125 kit includes (Fig.23):

- N°1 Wall sealing plate (3)
 - N°1 Aluminium tile (4)
 - N°1 Fixed half-shell (5)
 - N°1 Mobile half-shell (6)
 - N°1 Concentric intake/exhaust pipe Ø 80/125 (7)
- The remaining kit components must not be used

Extensions for vertical kit Ø 80/125 (Fig. 24)

The kit with this configuration can be extended to a max. straight vertical length of 32 m, including the terminal. If additional components are assembled, the length equivalent to the maximum allowed must be subtracted. In this case the special extensions must be requested.

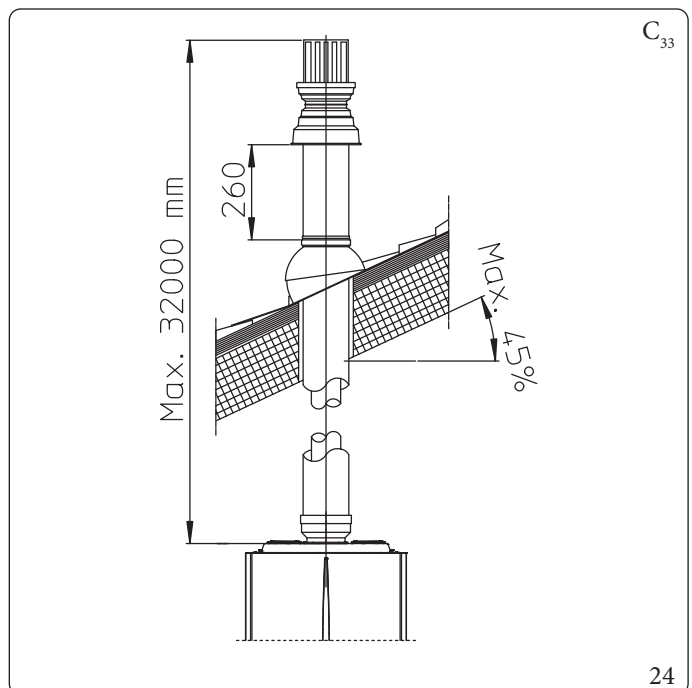

INSTALLER

USER

MAINTENANCE TECHNICIAN

TECHNICAL DATA

1.18 SEPARATOR KIT INSTALLATION

Type C configuration, sealed chamber and fan assisted, separator kit Ø 80/80

This kit allows air to come in from outside the building and the exhaust to exit from the chimney, flue or intubated duct through divided flue exhaust and air intake pipes.

Combustion products are expelled from pipe (S) (in plastic, so as to resist acid condensate).

Air is taken in through duct (A) for combustion (this is also in plastic).

The intake pipe (A) can be installed either on the right or left hand side of the central exhaust pipe (S).

Both ducts can be routed in any direction.

Assembly of separator kit Ø 80/80 (Fig. 25):

1. Install the flange (4) on the central hole of the appliance, positioning gasket (1) with the circular projections downwards in contact with the appliance flange.
2. Tighten with the hexagonal head and flat point screws provided in the kit.
3. Replace the flat flange present in the lateral hole with respect to the central one (according to needs) with the flange (3), positioning the gasket (2) already present in the appliance in between.
4. Tighten with the supplied self-tapping screws with drill bit.
5. Fit the bends with male side (smooth) (5) in the female side of the flanges (3 and 4).
6. Fit the intake terminal (6) with the male side (smooth) in the female side of the bend (5) up to the end stop, ensuring that the internal and external wall sealing plates are fitted
7. Fit the exhaust pipe (9) with the male end (smooth) to the female end of the bend (5) up to the end stop; making sure that the internal wall sealing plate has been fitted, this will ensure sealing and joining of the elements making up the kit.

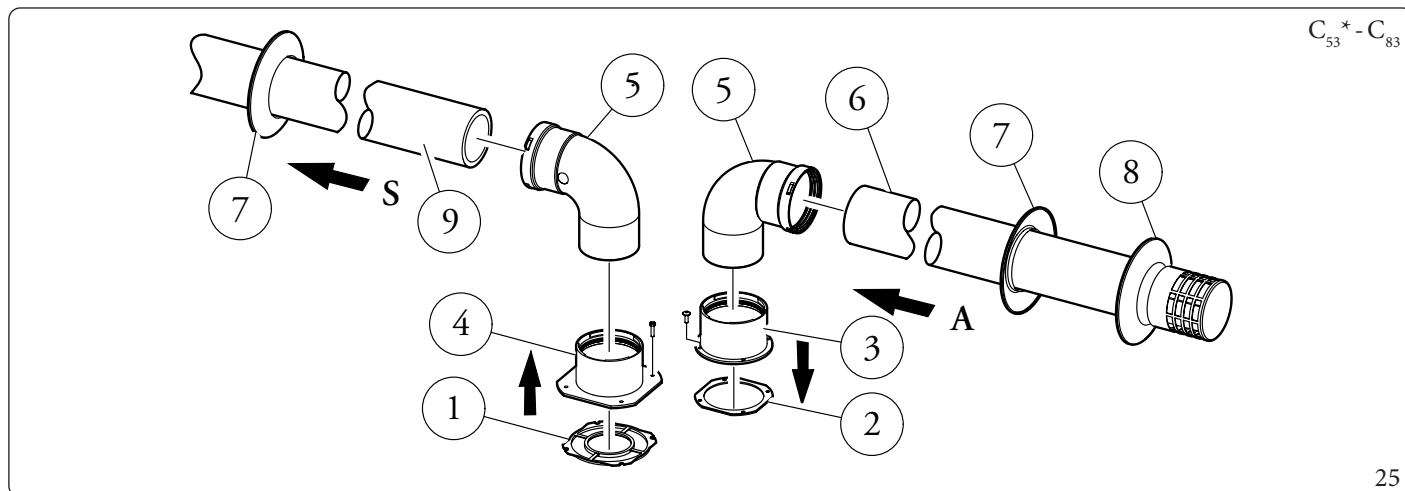

The kit includes (Fig. 25):

- N°1 Exhaust gasket (1)
- N°1 Flange gasket (2)
- N°1 Female intake flange (3)
- N°1 Female exhaust flange (4)
- N°2 Ø 80 90° bend (5)
- N°1 Intake terminal Ø 80 (6)

N°2 Internal wall sealing plates (7)

N°1 External wall sealing plate (8)

N°1 Exhaust pipe Ø 80 (9)

* to complete C53 configuration, also provide for a "green range" roof discharge terminal. The configuration on walls opposite the building is not allowed.

Installation clearances (Fig. 26)

The minimum installation clearance measurements of the Ø 80/80 separator terminal kit have been stated in some limit conditions.

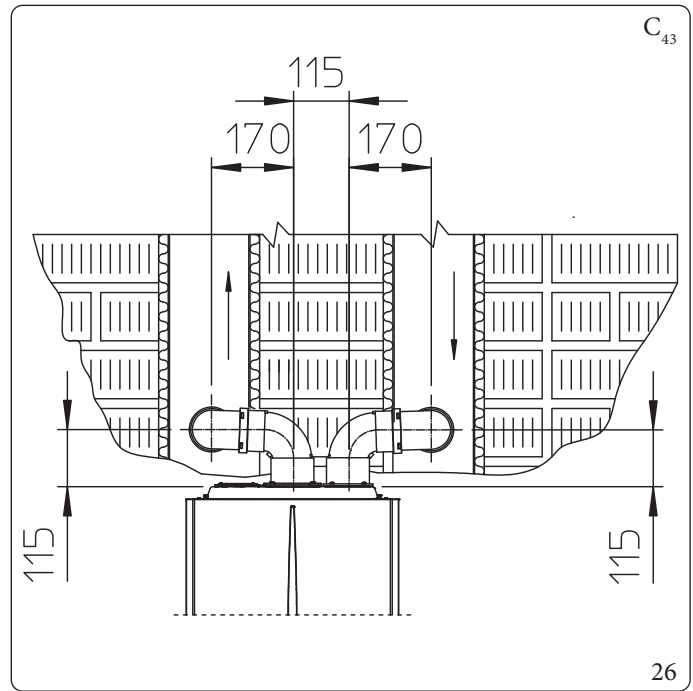

Extensions for separator kit Ø 80/80

The maximum vertical straight length (without bends) that can be used for Ø 80 intake and exhaust pipes is 41 metres, regardless from whether they are used for intake or exhaust.

The maximum horizontal straight length (with bend in suction and in exhaust) that can be used for Ø 80 intake and exhaust pipes is 36 metres, regardless from whether they are used for intake or exhaust.

Please note the type of installation C₄₃ must be done with a natural draught flue.



To aid in the removal of possible condensate forming in the exhaust pipe, tilt the pipes towards the appliance with a minimum slope of 5% (Fig. 27).

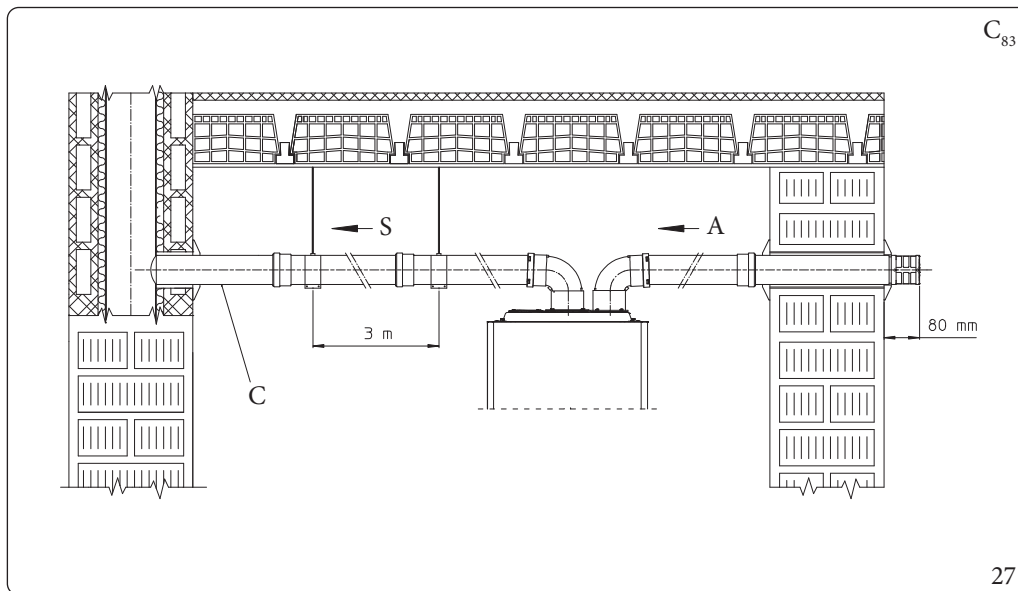

Key (Fig. 27):

- A - Intake
- C - Minimum slope 5%
- S - Exhaust

INSTALLER

USER

MAINTENANCE TECHNICIAN

TECHNICAL DATA

1.19 C9 ADAPTOR KIT INSTALLATION

This kit allows an Immergas appliance to be installed in "C₉₃" configuration, with combustion air intake directly from the shaft where the flue gas exhaust is, obtained by means of a ducting system.

System composition

The system must be combined with the following components (sold separately) to be functional and complete:

- kit C₉₃ Ø 100 or Ø 125 version;
- rigid ducting Ø 60 and Ø 80 and flexible Ø 50 and Ø 80 kit;
- flue exhaust kit Ø 60/100 or Ø 80/125 configured according to the installation and type of appliance.

Mounting adapter kit C₉ (Fig. 29)



(Version Ø 125 only) before assembly check the gaskets are in the right position.

In the event component lubrication (already carried out by the manufacturer) is not sufficient, remove the residual lubricant using a dry cloth, then to ease fitting coat the parts with common or industrial talc.



To aid in the removal of possible condensate forming in the exhaust pipe, tilt the pipes towards the appliance with a minimum slope of 5% (Fig. 27).

1. Mount the components of kit "C₉" on the door (A) of the ducting system (Fig.29).
2. (Version Ø 125 only) mount the flanged adaptor (11) interposing the concentric gasket (10) on the appliance, fitting it with the screws (12).
3. Mount the ducting system as described in the relative instructions sheet.
4. Calculate the distances between the appliance drain and the bend of the ducting system.
5. Prepare the appliance flue system, making sure that the internal pipe of the concentric kit is fitted up to the end stop in the ducting system curve (Quota "X" Fig. 30), whereas the external pipe must reach the end stop of the adaptor (1).
6. Mount the cover (A) complete with adaptor (1) and caps (6) on the wall.
7. Assemble the flue system to the ducting system.

Once all components have been assembled properly, the exhaust flue gas will be expelled via the ducting system; the combustion air for normal boiler operation will be aspirated directly by the shaft (Fig. 30).

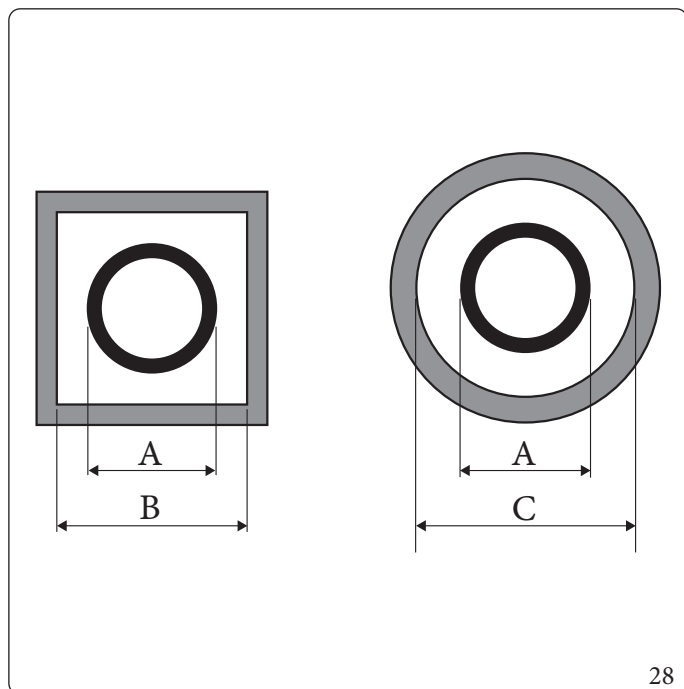

Ducting	ADAPTOR (A) mm	SHAFT (B) mm	SHAFT (C) mm
Ø 60 Rigid	66	106	126
Ø 50 Flexible	66	106	126
Ø 80 Rigid	86	126	146
Ø 80 Flexible	103	143	163

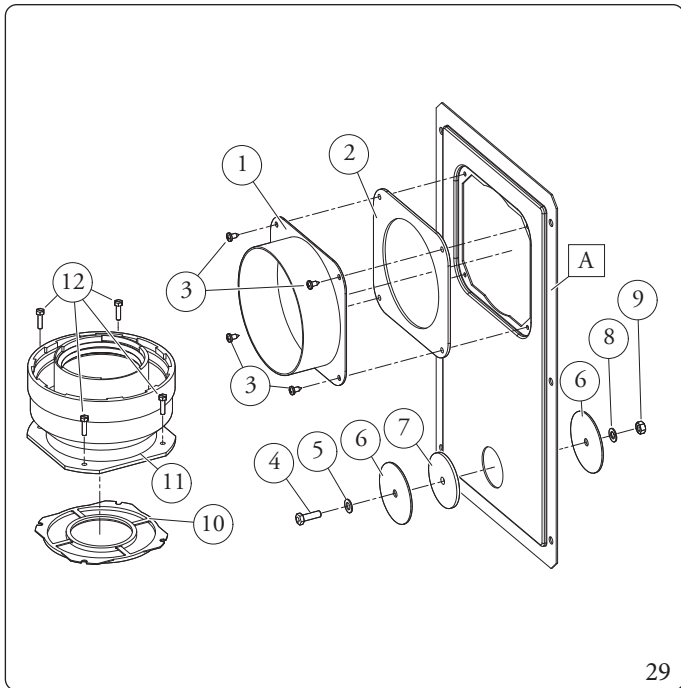

The adapter kit includes (Fig. 29):

- N°1 Door adaptor \varnothing 100 or \varnothing 125 (1)
- N°1 Door gasket made of neoprene (2)
- N°4 Screws 4.2x9 AF (3)
- N°1 Hexheaded screw M6x20 (4)
- N°1 Flat nylon washer M6 (5)
- N°2 Door hole closure metal-sheet plate plug (6)
- N°1 Plug gasket made of neoprene (7)
- N°1 Toothed washer M6 (8)
- N°1 Nut M6 (9)
- N°1 (kit \varnothing 80/125) Concentric gasket \varnothing 60/100 (10)
- N°1 (kit \varnothing 80/125) Flanged adapter \varnothing 80/125 (11)
- N°4 (kit \varnothing 80/125) Hexheaded screws M4x16 slotted screwdriver (12)
- N°1 (kit \varnothing 80/125) Bag of lubricating talc

Supplied separately (Fig. 29):

- N°1 Ducting kit door (A)

Technical data

The dimensions of the shafts must ensure a minimum gap between the outer wall of the smoke duct and the inner wall of the shaft: 30 mm for circular section shafts and 20 mm in the event of a square section shaft (Fig. 28).

Maximum 2 changes of direction are allowed on the vertical section of the flue system with a maximum clearance angle of 30° with respect to the vertical.

The maximum vertical extension using a \varnothing 60 ducting system is 13 m, the maximum extension includes 1 bend \varnothing 60/100 at 90° , 1 m of horizontal pipe \varnothing 60/100, 1 x 90° \varnothing 60 ducted bend and the roof terminal for ducting.

To determine the C_{93} flue system in configurations other than that described (Fig. 30) one must consider that a 1-metre ducted pipe according to the indications described has a resistance factor equal to 4.9.

The maximum vertical extension using a \varnothing 80 rigid ducting system is 28 m, the maximum extension includes 1 adapter from \varnothing 60/100 to \varnothing 80/125, 1 bend \varnothing 80/125 of 87° , 1 m of pipe \varnothing 80/125 in horizontal, 1 x 90° ducted bend \varnothing 80 and the roof terminal for ducting.

To determine the C_{93} flue system in configurations other than that described (Fig. 30) one must consider the following head losses:

- 1 m of concentric pipe \varnothing 80/125 = 1.8 m of rigid ducted pipe \varnothing 80 and 0.7 m of flexible ducted pipe \varnothing 80;
- 1 curve \varnothing 80 of 87° = 2.1 m of rigid ducted pipe \varnothing 80 and 0.9 m of flexible ducted pipe \varnothing 80.

Consequently one must subtract the equivalent length of the part added to the 28 m available.

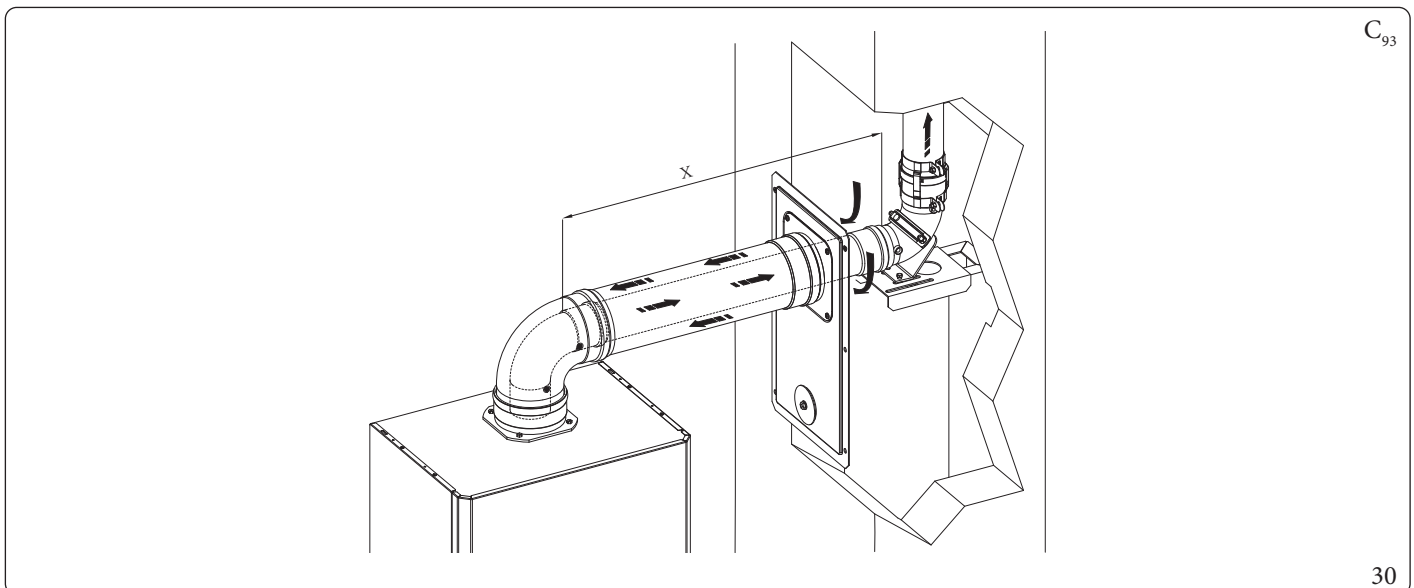

1.20 DUCTING OF FLUES OR TECHNICAL SLOTS

Ducting is an operation through which, via the introduction of one or more relevant pipes, one achieves a system for the evacuation of the combustion products of a gas appliance, made up from the coupling of an existing or new ducting pipe with a chimney, flue or technical slot (also in new buildings) (Fig. 31).

Ducting requires ducts declared to be suitable for the purpose by the manufacturer, following the installation and user instructions, provided by the manufacturer and the requirements of the regulations in force.

Immergas ducting systems



The Ø 60 rigid, Ø 50 and Ø 80 flexible and Ø 80 rigid “Green Range” ducting systems must only be used for domestic use and with Immergas condensing appliances.

In any case, ducting operations must respect the provisions contained in the standard and in current technical regulations; in particular, the declaration of conformity must be compiled at the end of work and on commissioning of the ducted system.

The instructions in the project or technical report must likewise be followed, in cases provided for by the standard and current technical regulations.

To guarantee reliability and operation over time of the ducting system, make sure:

- it is used in average atmospheric and environmental conditions, according to current regulations (absence of combustion products, dusts or gases that can alter the normal thermophysical or chemical conditions; existence of temperatures coming within the standard range of daily variation, etc.).
- Installation and maintenance must be performed according to the indications supplied by the manufacturer included with the “green range” ducting system chosen and in compliance with the regulations in force.
- The maximum length specified by the manufacturer must be respected; in this regard:
 - The max. possible length of the Ø 60 rigid ducting vertical section is equal to 22 m. This length is obtained considering the complete Ø 80 exhaust terminal, 1 m of Ø 80 pipe in exhaust, two 90° Ø 80 bends at appliance outlet.
 - The max. possible length of the Ø 80 flexible ducting vertical section is equal to 18 m. This length is obtained considering the Ø 80 complete exhaust terminal, 1 m of Ø 80 pipe in exhaust, two 90° Ø 80 bends at appliance outlet for connecting to the ducting system and two direction changes of the flexible hose inside the chimney/technical slot.
 - The max. possible length of the Ø 80 rigid ducting vertical section is equal to 30 m. This length is obtained considering the complete Ø 80 exhaust terminal, 1 m of Ø 80 pipe in exhaust, two 90° Ø 80 bends at appliance outlet.
 - The maximum vertical length of the Ø50 flexible ducted section is 20 m straight for Victrix Tera V2 28 EU, 15 m straight for Victrix Tera V2 32 EU and 12 m straight for Victrix Tera V2 38 EU. This length is obtained considering the complete Ø80 exhaust terminal, 1m of Ø80 pipe in exhaust, two 90° Ø80 bends at appliance outlet and the reduced Ø80/50 T fitting.

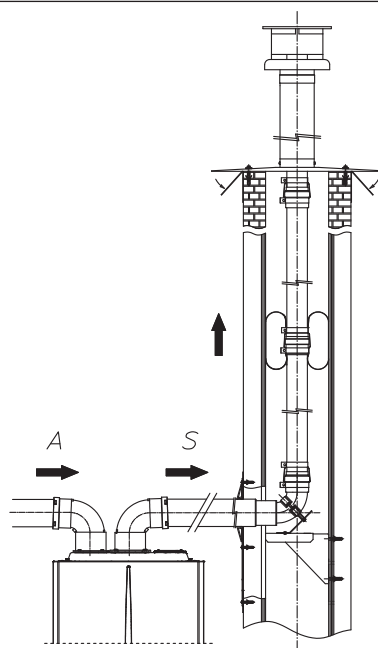
C₅₃

31

1.21 CONFIGURATION TYPE B, OPEN CHAMBER AND FAN ASSISTED FOR INDOORS

The appliance can be installed inside buildings in B₂₃ or B₅₃ mode; in this case, all technical rules and national and local regulations in force, must be complied with.

For installation, the cover kit must be used, referred to in (Par. 1.14).

1.22 FLUE EXHAUST TO FLUE/CHIMNEY.

Flue exhaust does not necessarily have to be connected to a branched type traditional flue for type B appliances with natural draught (CCR).

The flue exhaust, for boiler clots installed in C configuration, can be connected to a special LAS type multiple flue.

For B₂₃ configurations, exhaust is only allowed into individual chimney or directly into the external atmosphere via a relevant terminal, unless otherwise provided by local regulations.

The multiple flues and the combined flues must also only be connected to type C appliances of the same type (condensation), having nominal heat inputs that do not differ by more than 30% less with respect to the maximum that can be attached and powered by the same fuel.

The thermo-fluid dynamic features (flue flow rate, % of carbon dioxide, % humidity etc.) of the appliances attached to the same multiple flues or combined flues, must not differ by more than 10% with respect to the average appliance attached.

Multiple and combined flues must be specially designed according to the calculation method and requirements of the standards (such as UNI 13384), by professionally qualified technical staff.

Chimney or flue sections for connection of the flue exhaust pipe must comply with requisites of technical standards in force.

It is possible to replace a type C conventional device with one provided with condensation only, if the derogation conditions established by the regulations in force have been verified.

INSTALLER

USER

MAINTENANCE TECHNICIAN

TECHNICAL DATA

1.23 FLUES, CHIMNEYS AND CHIMNEY CAPS.

The flues, chimneys and chimney caps for the evacuation of combustion products must be in compliance with applicable standards. Chimneys and roof-installed exhaust terminals must comply with the outlet height and with the distance from technical volumes set forth by the technical standards in force.

Positioning the wall flue exhaust terminals.

The wall flue exhaust terminals must:

- be installed on external perimeter walls of the building (Fig. 32);
- be positioned according to the minimum distances specified in current technical standards.

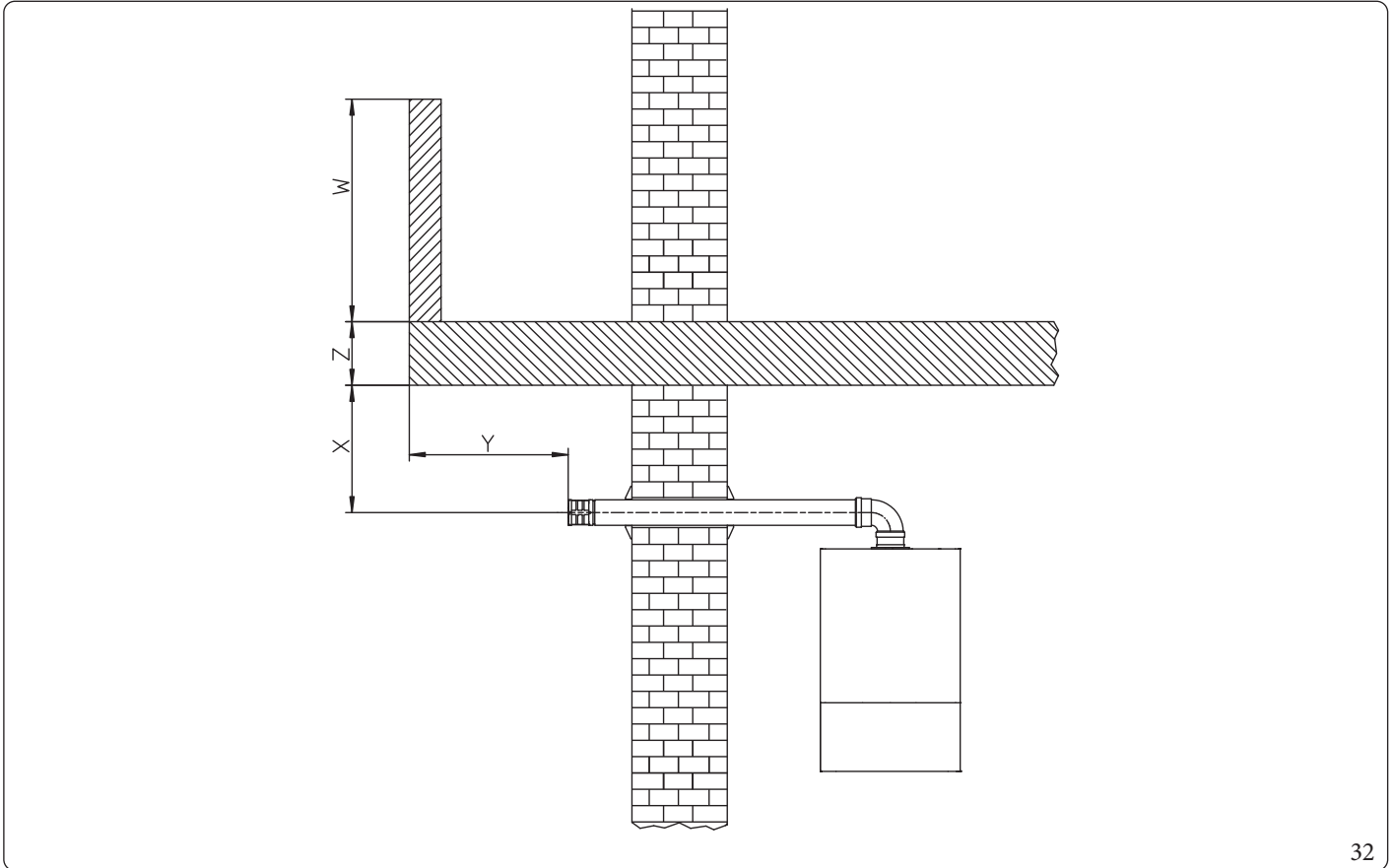

32

Combustion products exhaust of natural draught or fan assisted appliances in open-top closed environments.

In spaces closed on all sides with open tops (ventilation pits, courtyards etc.), direct combustion product exhaust is allowed for natural draught or fan assisted gas appliances with a heat input range from 4 to 35 kW, provided the conditions as per the current technical standards are respected.

1.24 WATER TREATMENT PLANT FILLING

As already mentioned in the previous paragraphs, a treatment of the thermal and domestic system water is required, in compliance with the local standards in force.

The parameters that influence the duration and proper operation of the heat exchanger are the water's PH, total hardness, conductivity, and oxygen, together with the system's processing residues (any welding residues), any oil present and corrosion products that can, in turn, cause damage to the heat exchanger.

In order to prevent this from happening, you are recommended to:

- clean the system with clean water to eliminate solid residues before installation on new and old systems;
- clean the system with a chemical treatment:
 - clean the new system with a suitable cleaning device (for example Sentinel X300, Fernox Cleaner F3 or Jenaqua 300) combined with thorough washing;
 - clean the old system with a suitable cleaning device (for example Sentinel X400 or X800, Fernox Cleaner F3 or Jenaqua 400) combined with thorough washing;
- Check the maximum total hardness and amount of filling water with reference to the graph (Fig. 33), if the contents and hardness of the water are below the indicated curve, no specific treatment is required; otherwise, to limit the content of calcium carbonate, you must provide for water-filling treatment.
- If it is necessary to provide for water treatment, it should be done through complete desalination of the filling water. As opposed to the complete softening process, desalinating the water completely not only removes hardening agents (Ca, Mg), but also eliminates all other minerals to reduce water-filling conductivity up to 10 microsiemens/cm. Given its low conductivity, desalinated water does not only prevent the formation of lime scale, but also serves as protection against corrosion.
- Insert a suitable inhibitor / passivator (for example Sentinel X100, Fernox Protector F1, or Jenaqua 100); if required, also insert appropriate antifreeze (such as for example Sentinel X500, Fernox Alphi 11 or Jenaqua 500).
- Check electrical conduction of the water, which should be higher than 2000 $\mu\text{s}/\text{cm}$ in the case of treated water and lower than 600 $\mu\text{s}/\text{cm}$ in the case of non-treated water.
- To prevent corrosion, the water system's PH should be between 7.5 and 9.5.
- Check the maximum content of chlorides, which should be less than 250 mg/l.



For quantities and methods of use of water-treatment products, refer to the instructions provided by their manufacturer.

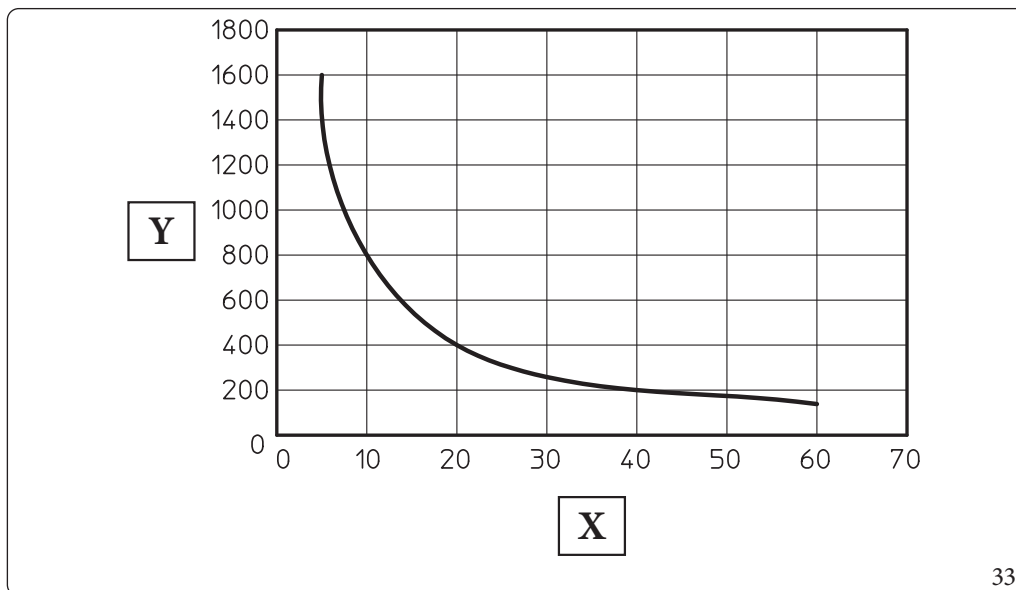

Key (Fig. 33):

- X - Total water hardness °F
- Y - Litres of system water



The graph refers to the entire life cycle of the system. Therefore, also consider scheduled and unscheduled maintenance, which involves emptying and filling the said system.

1.25 SYSTEM FILLING

Once the appliance is connected, proceed with system filling via the filling cock (Part. 27, Fig. 38).

Filling is performed at low speed to ensure release of air bubbles in the water via the appliance and central heating system vents.

The appliance has a built-in automatic vent valve on the pump.

Check if the cap is loose.

Then open the radiator vent valves.

Close radiator vent valves when only water escapes from them.

The filling cock must be closed when the appliance pressure gauge indicates approximately 1.2 bar cold.



During these operations, enable the automatic vent functions on the appliance (Parag. 3.14);

1.26 FILLING THE CONDENSATE DRAIN TRAP



When the appliance is switched on for the first time, combustion products come out of the condensate drain. After a few minutes of operation, check that combustion flue gases are no longer coming out of the condensate drain; this means that the drain trap has filled to a correct condensate height that the flue gases cannot pass through.

1.27 GAS SYSTEM START-UP.

To start up the system, refer to the technical standards in force.

This divides the systems and, therefore, the commissioning operations, into three categories: new systems, modified systems, reactivated systems.

In particular, for new gas systems:

- open windows and doors;
- avoid presence of sparks or naked flames;
- bleed all air from pipelines;
- ensure the internal system is properly sealed according to the specifications set forth by technical regulations in force.

1.28 APPLIANCE START-UP (IGNITION)

To commission the appliance (the operations listed below must only be performed by qualified personnel and in the presence of staff only):

1. check that the internal system is properly sealed according to the specifications set forth by regulations in force;
2. Ensure that the type of gas used corresponds to the appliance settings;
3. Check connection to a 230V~50Hz power mains, correct L-N polarity and the earthing connection;
4. Switch the appliance on and check correct ignition;
5. Make sure that the gas flow rate and relevant pressure values comply with those given in the manual (Par.4.1);
6. ensure that the safety device intervenes in the event of gas supply failure and check the relative intervention time;
7. Check the activation of the main switch located upstream of the appliance and in the appliance.
8. Check that the intake / exhaust terminals (if fitted) are not blocked;
9. Check that the drain trap is full and that it prevents any passage of flue gas into the room;
10. Carry out the flue test.



Even if just one single safety check provides a negative result, do not commission the system.

INSTALLER

USER

MAINTENANCE TECHNICIAN

TECHNICAL DATA

1.29 CIRCULATION PUMP

The appliances are supplied with a variable speed circulator pump.

In the central heating mode, the following operating modes are available and can be selected from the “P.C.B. programming” menu.



The ΔT (A3) can be controlled compatibly with the characteristics of the central heating system and of the appliance.

- **Proportional head (A3 = 0):** the circulator speed varies according to the power emitted by the burner, the greater the power the greater the speed.
- **ΔT Constant (A3 = 5 - 25 K):** the pump speed varies to maintain the ΔT constant between the system flow and return according to set value K (A3 = 15 Default).
- **Fixed:** by setting parameters “A1” and “A2” at the same value (7 - 9), the pump operates at constant speed. For the boiler to work properly, it is not allowed to drop below the minimum value indicated above.



In domestic hot water mode, the circulator pump always runs at full speed.

Pump symbols (Fig. 34):

The symbol 2 flashes green () when the pump is powered and the pwm control signal is on (pump ON).

The symbol 2 stays on steady green () when the pump is powered and the pwm control signal is off (pump in Stand-by). In this condition it is necessary to distinguish between two cases:

- the appliance electronics are not requesting pump ignition => condition OK;
- the appliance electronics are requesting the pump to switch on => faulty condition (probable disconnection of the pwm signal).

If the pump detects an alarm, symbol 1 lights up red (). This can mean that there is one of the following faults:

- Low power supply voltage.
- Rotor seized (Cautiously turn the screw in the centre of the head to manually release the motor shaft).
- Electrical error.



These anomalies will be signalled on the boiler display as errors “E60” or “E61”.

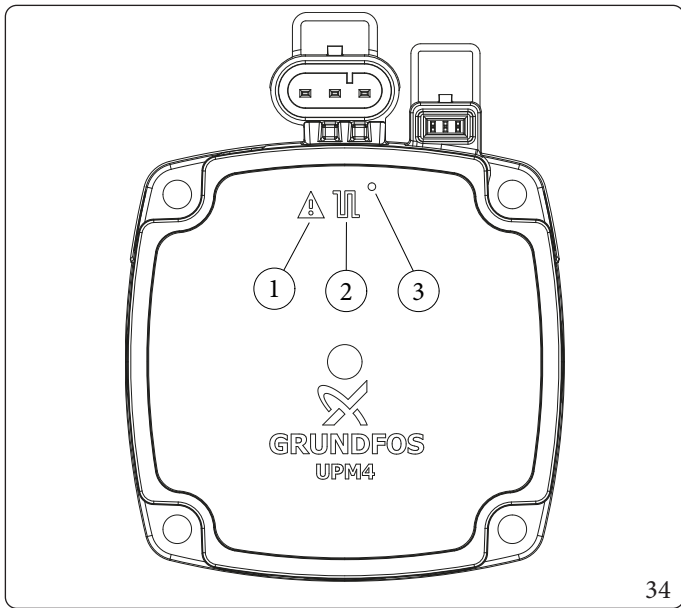

Key (Fig. 34):

- 1 - Alarm signal (Red)
- 2 - Functioning status signal (Steady green/Flashing green)
- 3 - Led (Not used on this model)

Pump release.

If after a long period of inactivity, the circulator is blocked, adjust the screw in the centre of the head in order to manually release the motor shaft.

Take great care during this operation to avoid damage to the motor.

Bypass Adjustment (Parag.1.31).



The bypass ensures minimum circulation of the water in the appliance and its correct operation if the systems are divided into more than one zone.

The appliance leaves the factory with the bypass open.

If necessary, the by-pass can be regulated to system requirements from minimum (by-pass closed) to maximum (by-pass open).

Adjust using a flat head screwdriver, turn clockwise and open the by-pass, anticlockwise it is closed.

Total head available to the system.

Victrix Tera V228 EU

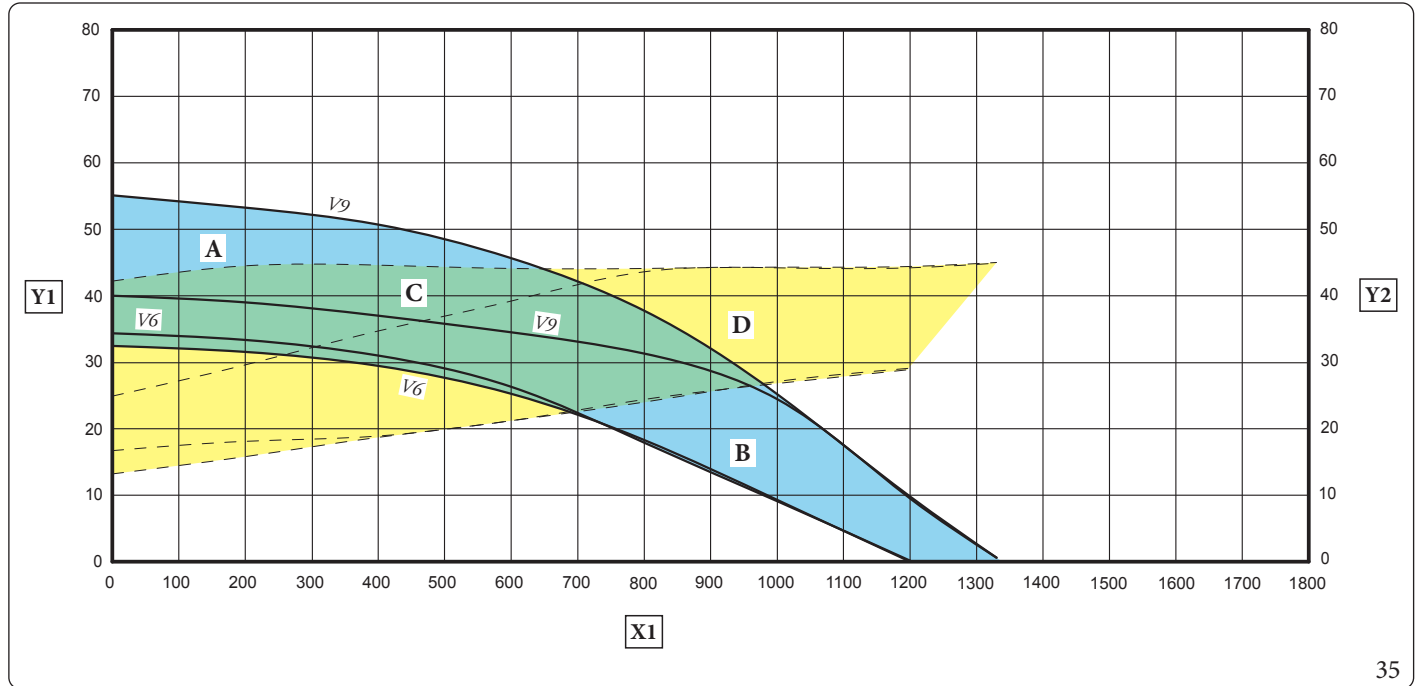

35

Victrix Tera V232 EU

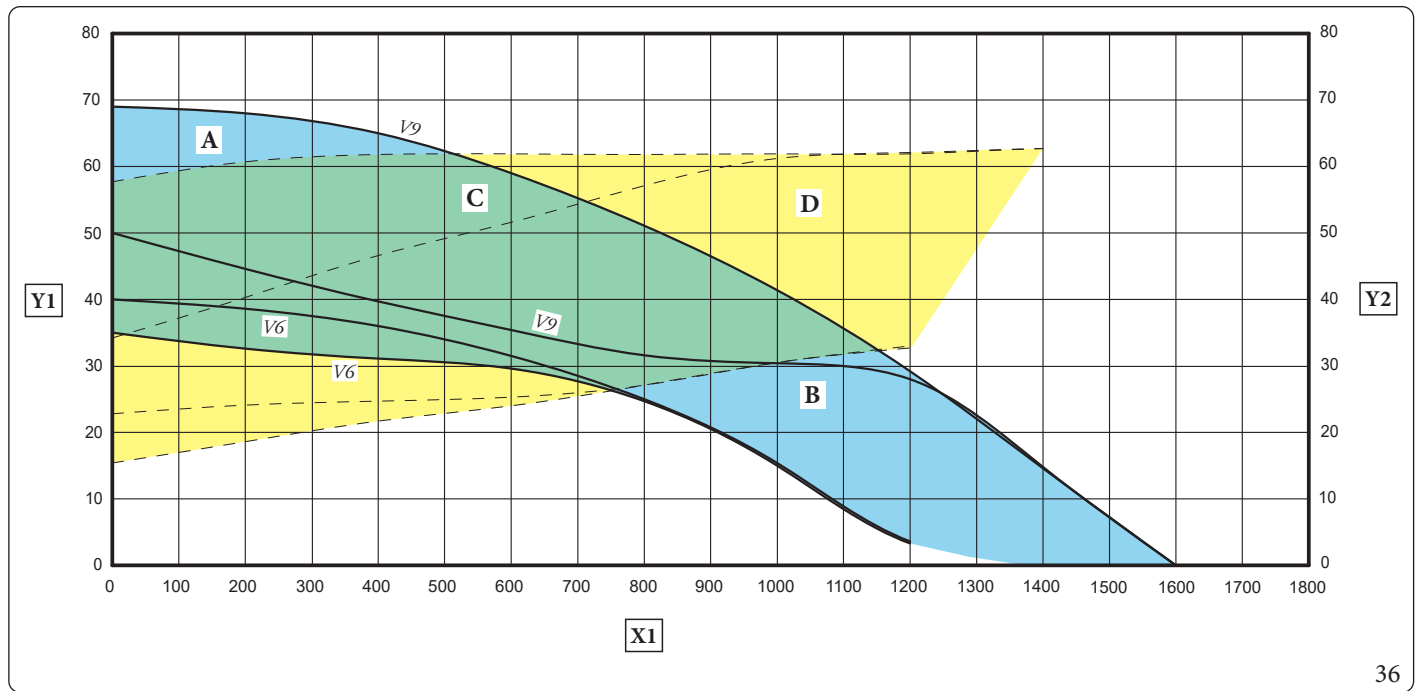

36

Key (Fig. 35; 36)

- X1 = Flowrate (l/h)
- Y1 = Head (kPa)
- Y2 = Circulator pump absorbed power (W)
- V6 = Speed 6
- V9 = Speed 9

- A+B = Head available with bypass closed
- B = Head available with bypass open
- C+D = Power absorbed by the pump with by-pass open (dotted area)
- D = Power absorbed by the pump with bypass closed (dotted area)

Total head available to the system.

Victrix Tera V2 38 EU

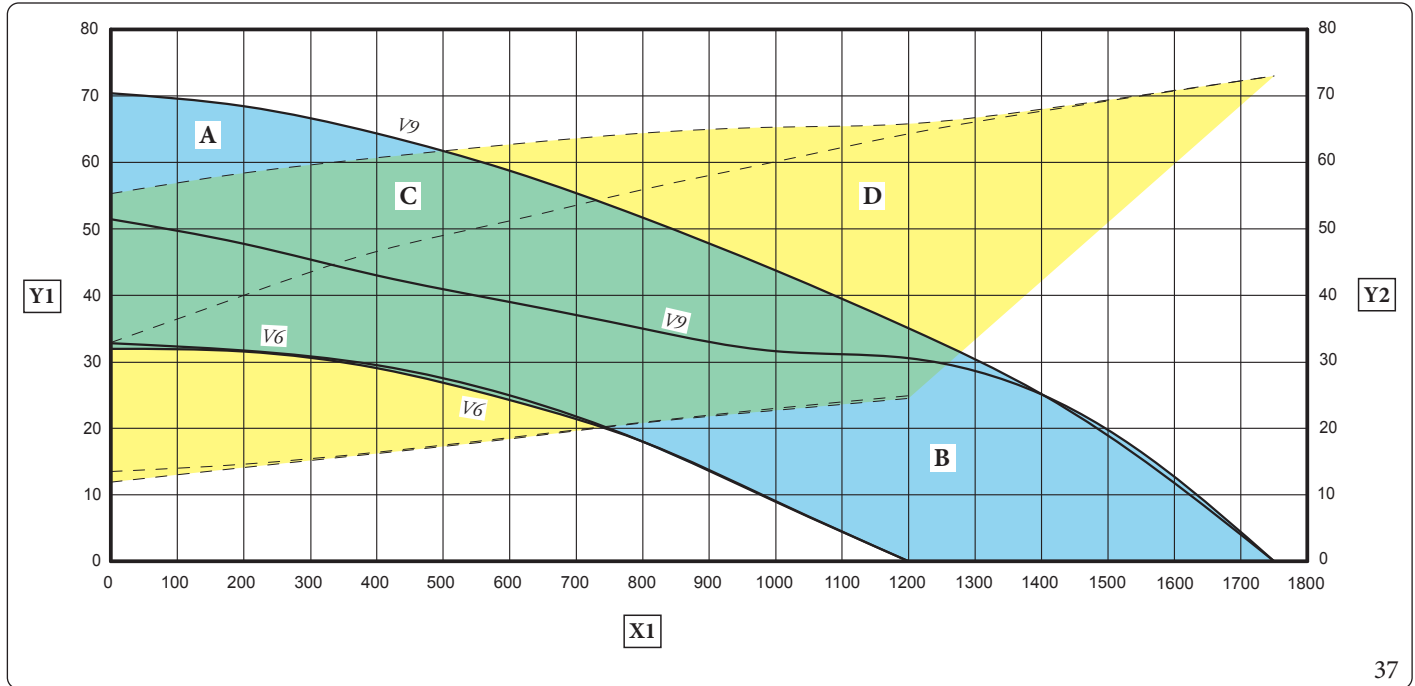

Key (Fig. 37)

X1 = Flow rate (l/h)

Y1 = Head (kPa)

Y2 = Circulator pump absorbed power (W)

V6 = Speed 6

V9 = Speed 9

A+B = Head available with bypass closed

B = Head available with bypass open

C+D = Power absorbed by the pump with by-pass open (dotted area)

D = Power absorbed by the pump with bypass closed (dotted area)

1.30 KITS AVAILABLE ON REQUEST



Check the complete list of kits available and which can be combined with the product, consult the Immergas website, the Immergas Price List or the technical-commercial documentation (catalogues and data sheets).

INSTALLER

USER

MAINTENANCE TECHNICIAN

TECHNICAL DATA

1.31 MAIN COMPONENTS

INSTALLER

USER

MAINTENANCE TECHNICIAN

TECHNICAL DATA

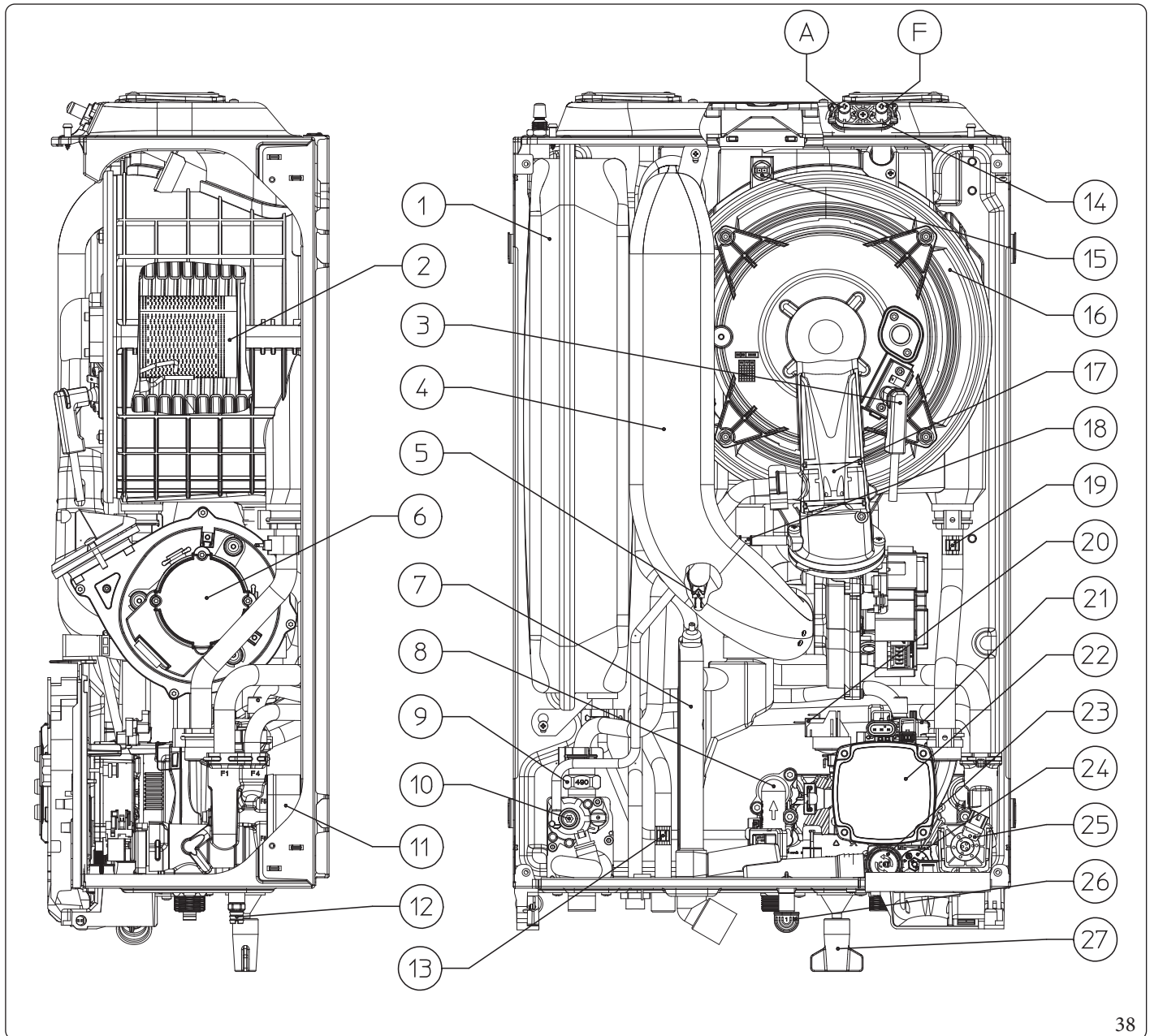

Key (Fig. 38):

- | | | | |
|----|--------------------------------|----|--|
| 1 | - System expansion vessel | 14 | - Sample points (air A) - (flue gases F) |
| 2 | - Burner | 15 | - Flue probe |
| 3 | - Ignition/detection electrode | 16 | - Condensation module |
| 4 | - Air intake pipe | 17 | - Venturi |
| 5 | - Flow probe | 18 | - Pressure signal vent fitting |
| 6 | - Fan | 19 | - Return probe |
| 7 | - Condensate drain trap | 20 | - System pressure switch |
| 8 | - D.H.W. flow switch | 21 | - Air vent valve |
| 9 | - Gas nozzle | 22 | - Boiler circulating pump |
| 10 | - Gas valve | 23 | - 3 bar safety valve |
| 11 | - D.H.W. heat exchanger | 24 | - By-pass |
| 12 | - System draining cock | 25 | - 3-way valve (motorised) |
| 13 | - D.H.W. probe | 26 | - Valve drain fitting signal |
| | | 27 | - System filling cock |

38

2 INSTRUCTIONS FOR USE AND MAINTENANCE

2.1 GENERAL RECOMMENDATIONS



Never expose the wall-mounted appliance to direct vapours from a hob.



The device can be used by children at least 8 years old as well as by persons with reduced physical, sensory or mental capabilities, or lack of experience or required knowledge, provided that they are under surveillance, or after they have been instructed relating to the safe use and have understood the potential dangers.

Children must not play with the appliance.

Cleaning and maintenance destined to be performed by the user can not be carried out by unsupervised children.



For safety purposes, check that the air intake/flue exhaust terminals (if fitted) are not blocked.



If temporary shutdown of the appliance is required, proceed as follows:

- a) drain the heating system if antifreeze is not used;
- b) shut-off all electrical, water and gas supplies.



In the case of work or maintenance to structures located in the vicinity of ducting or devices for flue extraction and relative accessories, switch off the appliance and on completion of operations ensure that a qualified technician checks efficiency of the ducting or other devices.



Never clean the appliance or connected parts with easily flammable substances.



Never leave containers or flammable substances in the same environment as the appliance.



Do not open or tamper with the appliance.



Do not take apart or tamper with the intake and exhaust pipes.



Only use the user interface devices listed in this section of the booklet.



Do not climb on the appliance, do not use the appliance as a support base.



The use of components involving use of electrical power requires some fundamental rules to be observed such as:

- do not touch the appliance with wet or moist parts of the body; do not touch when barefoot;
- never pull electrical cables or leave the appliance exposed to atmospheric agents (rain, sunlight, etc.);
- the appliance power cable must not be replaced by the user;
- in the event of damage to the power supply cable, switch off the appliance and contact exclusively qualified staff for replacement;
- if the appliance is not to be used for a certain period, disconnect the main appliance external switch.



Water at a temperature of more than 50 °C can cause serious burns. Always check the water temperature before any use.



The temperatures indicated by the display have a tolerance of +/- 3°C due to environmental conditions that cannot be blamed on the appliance.



If you smell gas in the building:

- close the gas meter interception device or the main interception device;
- if possible, close the gas interception cock on the product;
- if possible, open doors and windows wide and create an air current;
- do not use open flames (e.g. lighters, matches);
- do not smoke;
- do not use electrical switches, plugs, door bells, telephones or intercom devices in the building;
- call an authorised company (e.g. Authorised Technical Assistance Centre).



if you smell burning or see smoke coming out of the appliance, switch it off, disconnect power, close the main gas cock, open the windows and call an authorised company (e.g. Authorised Technical Assistance Centre).



At the end of its service life, the appliance must not be disposed of like normal household waste nor abandoned in the environment, but must be removed by a professionally authorised company as required by current legislation. Contact the manufacturer for disposal instructions.

2.2 CLEANING AND MAINTENANCE



To preserve the appliance's integrity and keep the safety features, performance and reliability, which distinguish it, unchanged over time, you must execute maintenance operations on a yearly basis in compliance with what is stated in the relative point at "annual check and maintenance of the appliance", in compliance with national, regional, or local standards in force.

2.3 CONTROL PANEL

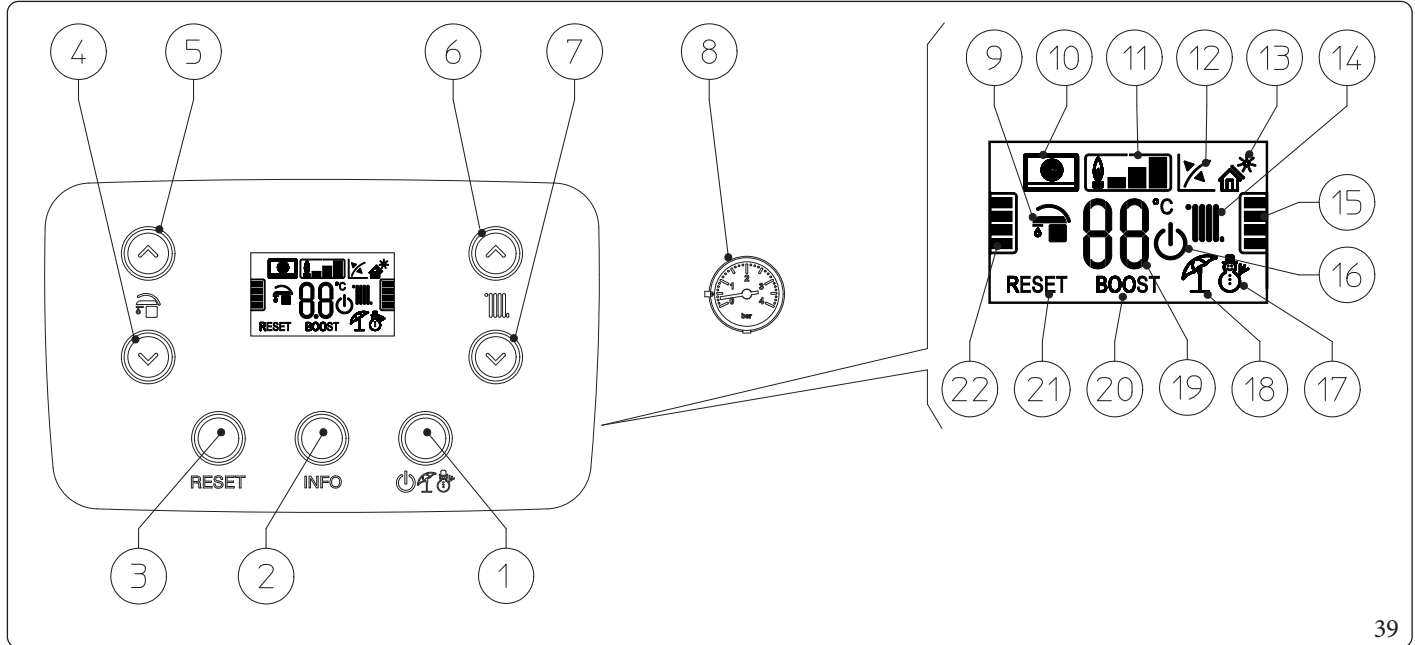





Key (Fig. 39):

- | | | | |
|----|--|----|---|
| 1 | - Off/Stand-by/Summer/Winter button | 11 | - Flame presence symbol and relative output scale |
| 2 | - Information buttons | 12 | - Operation with external temperature probe active (optional) |
| 3 | - Reset Button | 13 | - Solar function active |
| 4 | - Button to reduce the domestic hot water temperature | 14 | - Central heating room mode function active |
| 5 | - Button to increase the domestic hot water temperature | 15 | - Central heating temperature level indicator |
| 6 | - Button to increase the system water flow temperature | 16 | - Boiler in Stand-by mode |
| 7 | - Button to decrease the system water flow temperature | 17 | - Operation in winter mode |
| 8 | - Boiler manometer | 18 | - Operation in summer mode |
| 9 | - DHW production phase operating mode active | 19 | - Temperature indicator, boiler info and error codes |
| 10 | - Boiler connected to remote control ^{V2} (optional) or to other external devices | 20 | - Not used on this model |
| | | 21 | - Blocked boiler, it needs to be unblocked by pressing the "RESET" button |
| | | 22 | - D.H.W. temperature level indicator |

2.4 USING THE APPLIANCE





Before ignition make sure the heating system is filled with water and that the manometer (8) indicates a pressure of 1 - 1.2 bar.

- Open the gas cock upstream from the appliance.
- Press the button “  ” repeatedly to cyclically switch from “stand-by” () to “summer” () and “winter” () mode.

Summer

In this mode, the boiler functions only to produce the DHW, the temperature is set via the buttons  and the relative temperature is shown on the display via the indicator (19). Moreover, the temperature level that can be selected is shown on the indicator (22).

Winter ()

In this mode, the boiler functions both for producing domestic hot water and heating the environment. The DHW temperature is always regulated via the buttons “”, the central heating temperature is regulated via the buttons “” and the relative temperature is shown on the display via the indicator (Fig. 39). Moreover, the temperature level that can be selected is shown on the indicator (Fig. 39).

From this moment the boiler functions automatically. With no demand for heat (central heating or domestic hot water production) the boiler goes to “standby” function, equivalent to the boiler being powered without presence of flame. Each time the burner ignites, the relative flame present symbol is displayed (Fig. 39) with relative output scale.

Operation with Comando Amico Remoto^{v2} (CAR^{v2}) (optional)

If the CAR^{v2} is connected, the () symbol will appear on the display. The boiler regulation parameters can be set via the CAR^{v2} control panel and the Reset button (Fig. 39) remains active on the boiler control panel, along with the switch-off button (Fig. 39) (“Off” mode only) and the display where the functioning state is shown.



If the appliance is put into "off" mode, the “ERR>CM” connection error symbol will appear on the CAR^{v2}. The CAR^{v2} is however powered constantly so as not to lose memorised programs.

Solar function

This function is activated automatically if the boiler detects a probe on the DHW inlet (optional) or if the “Solar ignition delay” parameter is more than 0 seconds.

During a withdrawal, if the inlet water is hot enough or if there is “Solar ignition delay” time, the boiler does not switch on, the D.H.W. withdrawal symbol () appears on the display along with the flashing solar function symbol ().

When the water supplied by the solar system is at a temperature lower than what is set, and if the “Solar ignition delay” time has elapsed, the boiler switches on. At this point, the solar function symbol remains permanently on.



Operation with optional external probe (optional).

In the case of a system with an external probe, the boiler flow temperature for central heating is managed by the external probe depending on the external temperature measured (Par. 1.11). The flow temperature can be modified by selecting the functioning curve via the buttons  (or on the CAR^{V2} control panel, if connected to the boiler) selecting a value from “0 to 9”.

With external probe present, the relative symbol  will appear on the display. (Fig. 39).

In the central heating mode, if the temperature of the water contained in the system is sufficient to heat the radiators, the boiler can only function with the activation of the pump.

“Stand-by” Mode

Press button  repeatedly until the symbol () appears. The boiler remains off from this moment, though the antifreeze, pump anti-block and 3-way function and signalling of any anomalies are guaranteed.

OFF mode



In “Stand-by” and “Off” mode, the appliance is to be considered still live. In “Off” mode, a lit “dot” is displayed in the centre of the display.

Display operation

The display lights up while the control panel is being used; after a set inactivity period, the brightness drops until only the active symbols are displayed. The lighting mode can be varied via parameter “t8” in the P.C.B. programming menu.

2.5 FAULT AND ANOMALY SIGNALS

The boiler signals any anomalies using a code shown on the boiler display (Fig. 39) according to the following table:

Error Code	Anomaly signalled	Cause	Boiler status/ Solution
01	No ignition block	In the event of request of room central heating or domestic hot water production, the boiler does not switch on within the preset time. Upon appliance commissioning or after extended downtime, it may be necessary to eliminate the block.	Press the Reset button (1)
02	Safety thermostat function block (NTC flow/return overheating)	During normal operation, if a fault causes excessive overheating internally, the boiler goes into overheating block.	Press the Reset button (1)
03	Flue safety thermostat block	During normal operation, if a fault causes excessive flue gas overheating, the boiler blocks	Press the Reset button (1)
04	Contacts resistance block/Damaged hardware board	The P.C.B. detects a fault on the gas valve supply. Check its connection. (The fault is detected and displayed only in the presence of a request). Upon confirming that the fault does not concern the gas valve, you must replace the P.C.B. if the fault does not disappear after pressing the Reset button.	Press the Reset button (1)
05	Delivery probe fault	The board detects an anomaly on the flow NTC probe.	The boiler does not start (1)
06	DHW probe fault	The board detects an anomaly on the domestic hot water NTC probe. In this case the antifreeze function is also inhibited	In this case the boiler continues to produce domestic hot water but not with optimal performance (1)
08	Maximum N° of resets	Number of allowed resets already performed.	The anomaly can be reset 5 times consecutively, after which the function is inhibited for at least one hour. One attempt is gained every hour for a maximum of 5 attempts. By switching the appliance on and off again, the 5 attempts are re-acquired.
10	Insufficient system pressure	Water pressure inside the central heating circuit that is sufficient to guarantee the correct operation of the boiler is not detected.	Check on the boiler pressure gauge that the system pressure is between 1÷1.2 bar and restore the correct pressure if necessary.
(1) If the shutdown or fault persists, contact an authorised company (e.g. Authorised Service Centre)			
(2) The anomaly can only be verified in the list of errors in the “Information” menu			

Error Code	Anomaly signalled	Cause	Boiler status / Solution
15	Configuration error	If the board detects an anomaly or incongruity on the electric wiring, the boiler will not start.	If normal conditions are restored the boiler restarts without having to be reset. Check that the boiler is configured correctly (1)
16	Fan anomaly	This occurs if the fan has a mechanical or electrical fault.	Press the Reset button (1)
20	Parasite flame block	This occurs in the event of a leak on the detection circuit or anomaly in the flame control unit.	Press the Reset button (1)
23	Return probe anomaly	The board detects an anomaly on the return NTC probe	The boiler does not start (1)
24	Push button control panel anomaly	The board detects an anomaly on the pushbutton panel.	If normal conditions are restored the boiler restarts without having to be reset (1).
29	Flue probe anomaly	The board detects an anomaly on the flue probe.	The boiler does not start (1)
31	Loss of remote control communication	This occurs if an incompatible remote control is connected, or if communication between the boiler and the remote control is lost.	Disconnect and reconnect the power to the boiler. If the remote control is still not detected on re-starting, the boiler will switch to local operating mode, i.e. using the controls on the control panel. In this case, the "Central Heating" (1) function cannot be activated.
37	Low power supply voltage	This occurs when the power supply voltage is lower than the allowed limits for the correct boiler operation.	If normal conditions are restored the boiler restarts without having to be reset (1)
38	Loss of flame signal	This occurs when the boiler is ignited correctly and the burner flame switches off unexpectedly; a new attempt at ignition is performed and if normal conditions are restored, the boiler does not have to be reset.	If normal conditions are restored the boiler restarts without having to be reset (1) (2)
43	Block due to loss of flame signal	This occurs if the "Flame signal loss" error occurs many times in a row within a preset period (38).	Press the Reset button, before restarting, the boiler will run a post-ventilation cycle. (1)
(1) If the shutdown or fault persists, contact an authorised company (e.g. Authorised Service Centre)			
(2) The anomaly can only be verified in the list of errors in the "Information" menu			

Error Code	Anomaly signalled	Cause	Boiler status/ Solution
45	ΔT high	The boiler detects a sudden, unexpected increase in the ΔT between the flow probe and the system return probe.	The power of the burner is limited to prevent damage to the condensation module; once the right ΔT is restored, the boiler resumes regular operation. Make sure there is water circulating in the boiler, that the pump is configured according to system requirements and that the return probe works properly. (1) (2)
47	Burner power limitation	Should flue high temperature be detected, the boiler reduces power supplied so as not to damage it.	(1)
49	High temperature block on return probe	The temperature measured by the return probe is above 90°C. The block is with manual reset.	The error disappears when the temperature detected by the return probe drops below 70°C. Press the Reset button (1)
51	CAR Wireless communication failure	If there is no communication between the boiler and Wireless version CAR, an anomaly is signalled. From this moment, it is only possible to control the system by means of the control panel of the boiler itself.	Check operation of the Wireless CAR, check the battery charge (refer to the relative instructions booklet).
60	Anomaly pump blocked	The pump is stopped due to one of the following causes: Impeller blocked, electrical fault	Try to unblock the pump as described in the relative section. If normal conditions are restored the boiler restarts without having to be reset (1)
61	Air in circulator	Air is detected inside the pump; the pump cannot work.	Vent the pump and the central heating circuit. If normal conditions are restored the boiler restarts without having to be reset (1)
69	Not available	-	-
70	Return/flow probe exchange	In case of an incorrect boiler wiring connection the error is detected	The boiler does not start (1)
75	Return and/or flow probe malfunction	Possible failure of one or both system return and flow probes	The boiler does not start (1)
76	Flow and/or return probes temperature drift	A malfunction of one or both system return and flow probes is detected.	The boiler does not start (1)

(1) If the shutdown or fault persists, contact an authorised company (e.g. Authorised Service Centre)

2.6 INFORMATION MENU

Information menu

By pressing the button “INFO”, the “Information menu” is activated for at least 1 second, displaying some boiler operating parameters.

Press buttons  to scroll through the various parameters.

With the menu active on the indicator (Fig. 39) the parameter via the letter “d” plus the number of the parameter that is being displayed will alternately show.

To view the parameter value, select it by pressing the button “  ”.

Press “RESET” or wait 15 minutes to go back to the previous screen or exit the menu.

Parameter ID	Description
d0.0	Not used
d0.1	Displays the flame signal (uA)
d0.2	Displays the primary heat exchanger output instant heating flow temperature
d0.3	Displays the instant output temperature from the DHW exchanger
d0.4	Displays the values set for central heating set
d0.5	Displays the values set for DHW set
d0.6	Displays the external environment temperature (if optional external probe present). If the temperature is below zero, the value is displayed flashing.
d0.7	Displays the temperature of the inlet DHW (with optional DHW inlet probe present)
d0.8	Displays the system return water temperature
d0.9	Displays the list of the last eight faults (to scroll the list press the “central heating temperature regulation” buttons )
d1.0	Anomaly list reset. Once “d10” is displayed, press Stand-by; the display shows “--”. Then press the Stand-by key again for at least 3 seconds; deletion is confirmed via the “88” symbols flashing for two seconds.
d1.1	Not used
d1.2	Displays the pump operating speed
d1.3	Not used
d1.4	Displays the pump flow rate (lh/100)
d1.5	Displays the fan operating speed (rpm/100)
d1.6	Displays the temperature read on the flue probe
d1.7	Displays the calculated flow temperature
d1.8	At the end of the screed heater function, displays for how many hours the flow temperature remained at “Top set”
d1.9	Toggles between the safety software version and the functional software version
d2.0	Displays the flow temperature of zone two (optional)
d2.1	Displays the flow temperature of zone three (optional)
d2.2	Not used

2.7 APPLIANCE SWITCH-OFF

Switch the appliance off by putting it in “off” mode, disconnect the main switch outside of the appliance and close the gas cock upstream of the appliance.

Never leave the appliance switched on if left unused for prolonged periods.

2.8 RESTORE CENTRAL HEATING SYSTEM PRESSURE

1. Periodically check the system water pressure (the appliance’s pressure gauge hand must indicate a cold value between 1 and 1.2 bar).
2. If the pressure is below 1 bar (with the circuit cool), restore normal pressure from the relative cock (Part. 1, Fig. 7).
3. Close the cock after the operation.
4. If the pressure reaches values around 3 bar, there is a risk of tripping the safety valve (in this case, remove water from a radiator air vent valve until a pressure of 1 bar is achieved, or ask for assistance from professionally qualified personnel).
5. In the event of frequent pressure drops, contact qualified staff for assistance to eliminate the possible system leakage.

2.9 DRAINING THE SYSTEM

To drain the boiler, use the special draining valve (Part. 2, Fig. 7).

Before draining, ensure that the filling cock is closed.



If fluid containing glycol was added to the system circuit, make sure it is recovered and disposed of in accordance with standard EN 1717.

2.10 EMPTYING THE D.H.W. CIRCUIT

To do this, always close the domestic cold water inlet upstream of the appliance.

Open any domestic hot water tap to discharge the pressure from the circuit.

2.11 ANTIFREEZE PROTECTION

The appliance has an antifreeze function that switches the burner on automatically when the temperature drops below 4°C (standard protection to minimum temperature of -5°C).

In order to guarantee the integrity of the appliance and the domestic hot water heating system in areas where the temperature drops below zero, we recommend protecting the central heating system using anti-freeze liquid and installing the Immergas Antifreeze Kit in the appliance.

All information relative to the antifreeze protection is stated in (Parag. 1.4).

1. to switch off the power supply;
2. completely empty the CH circuit (to be avoided if glycol is present in the system) and the appliance's DHW circuit. In systems that are drained frequently, filling must be carried out with suitably treated water to eliminate hardness that can cause lime-scale.

2.12 CLEANING THE CASE

1. Use damp cloths and neutral detergent to clean the appliance casing.



Never use abrasive or powder detergents.

2.13 PERMANENT SHUTDOWN

In the event of permanent shutdown of the appliance, contact professional staff for the procedures and ensure that the electrical, water and gas supply lines are shut off and disconnected.

3 INSTRUCTIONS FOR MAINTENANCE AND INITIAL CHECK

3.1 GENERAL RECOMMENDATIONS

INSTALLER



**Operators who install and service the appliance must wear the personal protective equipment (PPE) required by applicable law.
The list of possible PPE is not complete as they are indicated by the employer.**

USER



Before carrying out any maintenance work, make sure that:

- you have disconnected the power to the appliance;
- you have closed the gas cock;
- you have discharged the pressure from the system and domestic hot water circuit.

MAINTENANCE TECHNICIAN

PX42 Gas Valve



Risk of material damage after using sprays and liquids to search for leaks

Leak sprays and liquids clog the reference hole P1. Ref. (Fig. 42) of the gas valve, damaging it irreparably.
During installation and maintenance, do not use spray or liquids in the upper area of the gas valve (side referring to the electric connections).

SIT 848 GAS Valve



Risk of material damage after using sprays and liquids to search for leaks

Leak sprays and liquids clog the reference hole PR Ref. (Fig. 43) of the gas valve, damaging it irreparably.
During installation and maintenance, do not use spray or liquids in the upper area of the gas valve (side referring to the electric connections).



Supply of spare parts

The device's warranty shall be rendered null and void if unapproved or unsuitable parts are used for maintenance or repairs. These will also compromise the product's compliance, and the said product may no longer be valid and fail to meet the current regulations. In regard to the above, only use original Immergas spare parts when replacing components.



If additional documentation needs to be consulted for extraordinary maintenance, contact the Authorised After-Sales Service.

TECHNICAL DATA

3.2 INITIAL CHECK

Commissioning the appliance requires you to:

- check the existence of the declaration of system conformity;
- make sure that the type of gas used corresponds to boiler settings;
- check connection to a 230V-50Hz power mains, correct L-N polarity and the earthing connection;
- make sure the central heating system is filled with water and that the boiler manometer indicates a pressure of 1÷1.2 bar;
- switch the appliance on and check correct ignition;
- check the proper calibration of the number of fan revolutions;
- check the CO₂/O₂ in the flue gas at maximum and minimum flow rate:
- the values comply with the relevant tables (Par. 3.3);
- check activation of the safety device in the event of no gas, as well as the relative activation time;
- check the activation of the main switch located upstream of the appliance;
- check that the intake and/or exhaust terminals are not blocked;
- ensure activation of all adjustment devices;
- seal the gas flow regulation devices (if the settings are changed);
- ensure production of domestic hot water;
- check the tightness of the hydraulic circuits;
- check ventilation and/or aeration of the installation room where provided.



Even if just one single safety check provides a negative result, do not commission the system.

INSTALLER

USER

MAINTENANCE/TECHNICIAN

TECHNICAL DATA

3.3 YEARLY APPLIANCE CHECK AND MAINTENANCE



The following checks and maintenance should be performed once a year to ensure operation, safety and efficiency of the appliance over time.

INSTALLER

- Clean the flue side of the heat exchanger.
- Clean the main burner.
- Check the correct positioning, integrity and cleanliness of the detection and ignition electrode; remove any oxide present.
- If deposits are detected in the combustion chamber they must be removed and the heat exchanger coils must be cleaned using nylon or broomcorn brushes; it is forbidden to use brushes made of metal or other materials that may damage the combustion chamber. It is also forbidden to use alkaline or acid detergents.
- Check the integrity of the insulating panels inside the combustion chamber and if damaged replace them.
- Visually check for water leaks or oxidation from/on connections and traces of condensate residues inside the sealed chamber.
- Check the contents of the condensate drain trap.
- Check that there are no material residues in the condensate drain siphon clogging the condensate passage; also check that the entire condensate drainage circuit is clear and efficient.

USER

- In the event of obstructions (dirt, sediment, etc.) with consequent leakage of condensate in the combustion chamber, one must replace the insulating panels.
- Check that the burner and gas manifold seal gaskets are intact and perfectly efficient, otherwise replace them. In any case the gaskets must be replaced at least every two years, regardless of their state of wear.
- Check that the burner is intact, that it has no deformations or cuts and that it is properly fixed to the combustion chamber lid; otherwise it must be replaced.
- Visually check that the water safety drain valve is not blocked.
- Check that, after discharging the system pressure and bringing it to zero (read on boiler pressure gauge), the expansion vessel pressure is at 1.0 bar.
- Check that the system static pressure (with system cold and after refilling the system by means of the filling valve) is between 1 and 1.2 bar.

MAINTENANCE TECHNICIAN

- Check visually that the safety and control devices have not been tampered with and/or shorted, in particular:
 - the power supply wires must be housed in the cable glands;
 - there must be no traces of blackening or burning.
- Check correct lighting and operation.
- Check the CO_2/O_2 by using the chimney sweep function at the reference heat outputs, using the parameters in the table below. Should values out of the indicated tolerance range be detected, check the calibration again (See par. 3.9).
- Check correct operation of control and adjustment devices and in particular:
 - system regulation probes intervention;
 - Domestic hot water control thermostat intervention.
- Check sealing efficiency of gas circuit and the internal system.
- Check the intervention of the device against no gas ionisation flame control. Intervention time must be less than 10 seconds.

TECHNICAL DATA

Victrix Tera V2 28 EU

Gastype	CO ₂ to nominal Q.	CO ₂ to ignition Q.	CO ₂ to minimum Q.
G20	9,2 (9,1 ÷ 9,5)	9,1 (9,0 ÷ 9,4)	8,5 (8,3 ÷ 8,7)
G31	10,2 (10,0 ÷ 10,4)	10,2 (10,0 ÷ 10,4)	9,7 (9,5 ÷ 9,9)

Gastype	O ₂ at Nominal Q.	O ₂ at Ignition Q.	O ₂ at Minimum Q.
G20	4,4 (4,6 ÷ 3,9)	4,6 (4,8 ÷ 4,1)	5,7 (6,0 ÷ 5,3)

Victrix Tera V2 32 EU

Gastype	CO ₂ to nominal Q.	CO ₂ to ignition Q.	CO ₂ to minimum Q.
G20	9,2 (9,1 ÷ 9,5)	9,2 (9,1 ÷ 9,5)	8,6 (8,3 ÷ 8,7)
G31	10,3 (10,1 ÷ 10,5)	10,2 (10,1 ÷ 10,5)	9,6 (9,4 ÷ 9,8)

Gastype	O ₂ at Nominal Q.	O ₂ at Ignition Q.	O ₂ at Minimum Q.
G20	4,4 (4,6 ÷ 3,9)	4,5 (4,6 ÷ 3,9)	5,5 (6,0 ÷ 5,3)

Victrix Tera V2 38 EU

Gastype	CO ₂ to nominal Q.	CO ₂ to ignition Q.	CO ₂ to minimum Q.
G20	9,0 (8,9 ÷ 9,3)	9,0 (8,9 ÷ 9,3)	8,5 (8,2 ÷ 8,6)
G31	10,2 (10,1 ÷ 10,4)	10,2 (10,0 ÷ 10,4)	9,6 (9,4 ÷ 9,8)

Gastype	O ₂ at Nominal Q.	O ₂ at Ignition Q.	O ₂ at Minimum Q.
G20	4,8 (5,0 ÷ 4,2)	4,8 (5,0 ÷ 4,2)	5,7 (6,2 ÷ 5,5)



If a Hydrogen ready installation is envisaged for H₂ percentages up to 20%, all gas valve calibration operations must refer to the O₂ values in the table above.



In addition to yearly maintenance, one must also check the energy efficiency of the thermal system, with frequency and procedures that comply with the indications of the technical regulations in force.



When adjusting Nominal Q., if the O₂ values are not reached with the gas flow regulator completely open, no further adjustments are required.

3.4 HYDRAULIC DIAGRAM

INSTALLER

USER

MAINTENANCE TECHNICIAN

TECHNICAL DATA

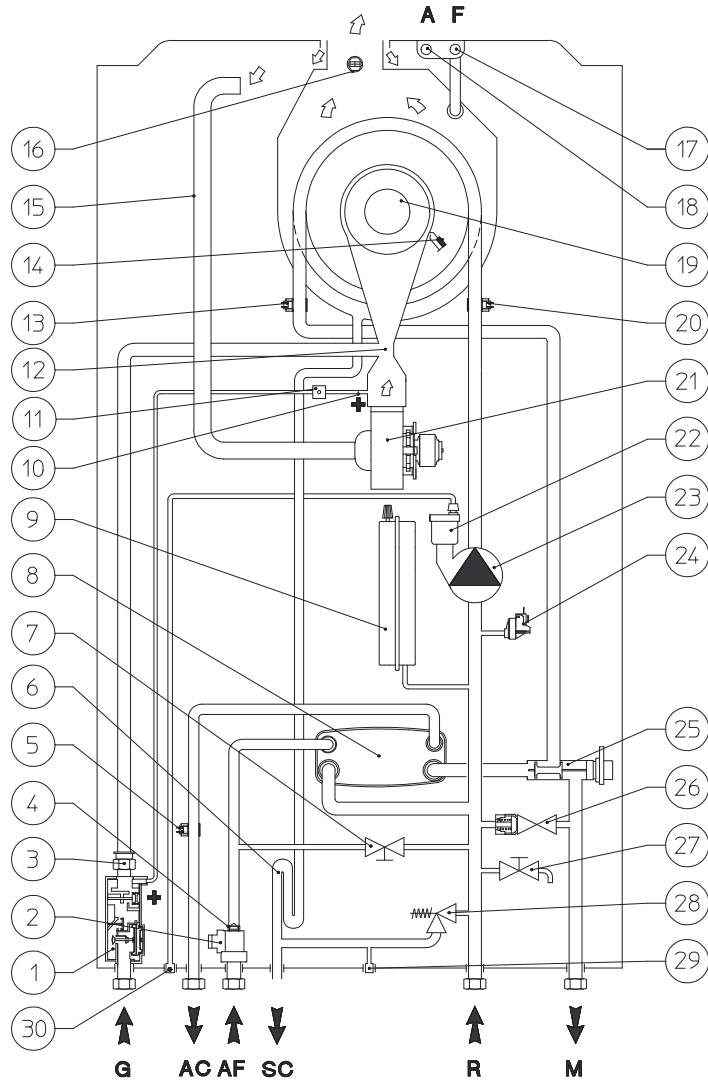

Key (Fig. 40):

- | | | | |
|----|---------------------------------|----|---|
| 1 | - Gas valve | 19 | - Burner |
| 2 | - D.H.W. flow switch | 20 | - Return probe |
| 3 | - Gas nozzle | 21 | - Fan |
| 4 | - Flow limiter | 22 | - Air vent valve |
| 5 | - D.H.W. probe | 23 | - Boiler circulating pump |
| 6 | - Condensate drain trap | 24 | - Absolute pressure switch |
| 7 | - System filling cock | 25 | - 3-way valve (motorised) |
| 8 | - D.H.W. heat exchanger | 26 | - By-pass |
| 9 | - System expansion vessel | 27 | - System draining cock |
| 10 | - Positive (+) pressure point | 28 | - 3 bar safety valve |
| 11 | - Pressure signal vent fitting | 29 | - 3 bar safety valve drain fitting signal |
| 12 | - Venturi | 30 | - Air vent valve drain |
| 13 | - Flow probe | | |
| 14 | - Ignition/ detection electrode | G | - Gas supply |
| 15 | - Air intake pipe | AC | - Domestic hot water outlet |
| 16 | - Flue probe | AF | - Domestic hot water inlet |
| 17 | - Flue sample point | SC | - Condensate drain |
| 18 | - Air sample point | M | - System flow |
| | | R | - System return |

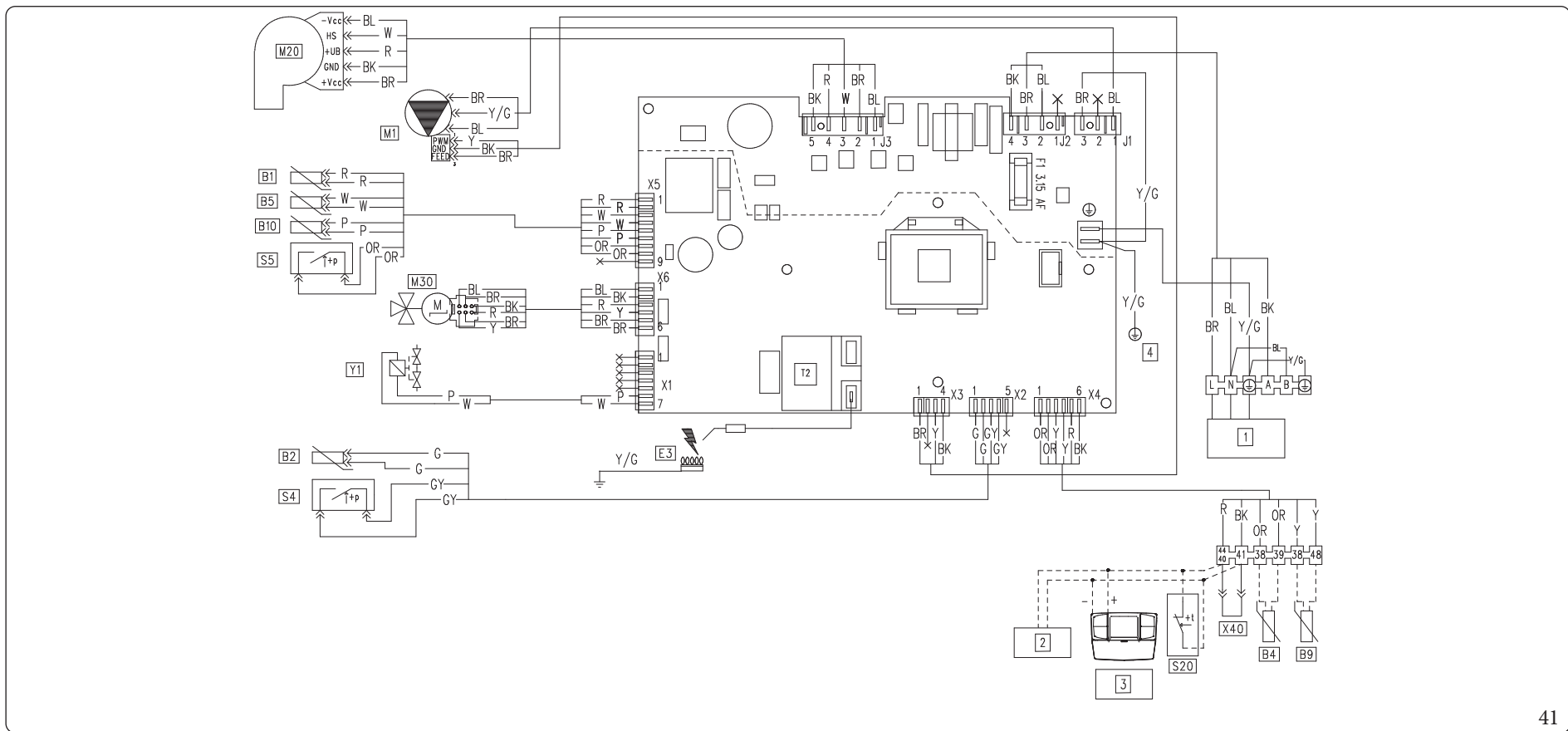

41

Key (Fig. 41):

- B1 - Flow probe
- B2 - D.H.W. probe
- B4 - External probe (optional)
- B5 - Return probe
- B9 - DHW inlet probe (optional)
- B10 - Flue probe
- CAR^{V2} - Comando Amico Remoto ^{V2} remote control (optional)

- E3 - Ignition and detection electrode
- M1 - Boiler circulating pump
- M20 - Fan
- M30 - Three-way stepper motor
- S4 - D.H.W. flow switch
- S5 - System pressure switch
- S20 - Room thermostat (optional)
- T2 - Ignition transformer
- X40 - Room thermostat jumper
- Y1 - Gas valve

Colour code key (Fig. 41):

- BK - Black
- BL - Blue
- BR - Brown
- G - Green
- GY - Grey
- OR - Orange
- P - Purple
- PK - Pink

- R - Red
- W - White
- Y - Yellow
- Y/G - Yellow/Green
- 1 - 230 Vac - 50Hz Power supply
- 2 - IMGBUS (optional)
- 3 - CAR₂^{V2}
- 4 - Earth - Frame

Comando Amico Remoto^{V2}: the boiler is prepared for the application of the Comando Amico Remoto remote control ^{V2} (CAR^{V2}), which must be connected to clamps 41 and 44/40 of the terminal board (located in the boiler control panel) respecting the polarity and eliminating jumper X40.

Room thermostat: the boiler is prepared for the application of the room thermostat (S20), which must be connected to clamps 44/40 - 41 of the terminal board (located in the boiler control panel) eliminating jumper X40.

3.6 TROUBLESHOOTING



Maintenance operations must be carried out by an authorised company (e.g. Authorised After-Sales Technical Assistance Centre).

Trouble	Possible causes	Solutions
Smell of gas	Caused by leakage from gas circuit pipelines.	Check sealing efficiency of gas intake circuit.
Repeated ignition blocks	No gas. Condensate drain clogged.	Check the presence of pressure in the network and that the gas adduction cock is open. Restore/release the function of the condensate drain, checking that the condensate has not affected: combustion components, fan and gas valve. Check the function of the condensate sensor.
Irregular combustion or noisiness	Dirty burner, clogged primary heat exchanger, incorrect combustion parameters, intake-exhaust terminal not correctly installed.	Check the indicated components.
Frequent trips of the overheating safety device thermostat function.	Lack of water in the appliance, little water circulation in the system or blocked pump (Par. 1.29).	Check on the pressure gauge that the system pressure is within established limits. Check that the radiator valves are not closed and also the functionality of the pump.
Siphon blocked	Dirt or combustion products deposited inside.	Check that there are no residues of material blocking the flow of condensate.
Heat exchanger blocked.	Obstruction of the siphon.	Check that there are no residues of material blocking the flow of condensate.
Abnormal noises in the system	Air in the system.	Check the opening of the cap of the air vent valve (Par. 1.31). Make sure the system pressure and expansion vessel pre-charge values are within the set limits. The factory-set pressure values of the expansion vessel must be 1.0 bar, the value of system pressure must be between 1 and 1.2 bar.

3.7 CONVERTING THE APPLIANCE TO OTHER TYPES OF GAS



The gas conversion operation must be carried out by an authorised company (e.g. Authorised Technical Assistance Service).

If the appliance needs to be converted to a different gas type to that specified on the data plate, request the relative conversion kit for quick and easy conversion.

To convert to another type of gas the following operations are required:

- Disconnect power to the appliance;
- Replace the nozzle (Part. 9, Fig. 38) taking care to disconnect the voltage to the appliance during this operation;
- Re-power the appliance;
- Calibrate fan speed (Par. 3.8);
- Adjust the CO₂/O₂ (Par. 3.9).
- Seal the gas flow rate regulation devices (if settings are modified);
- After completing the conversion, apply the sticker, contained in the conversion kit, on the data plate (Fig. 8) in the area relating to the type of gas. Using an indelible marker pen, delete the data relative to the old type of gas.

These adjustments must be made with reference to the type of gas used, following that given in the table (Paragraph 4.2).

PX42 Gas Valve

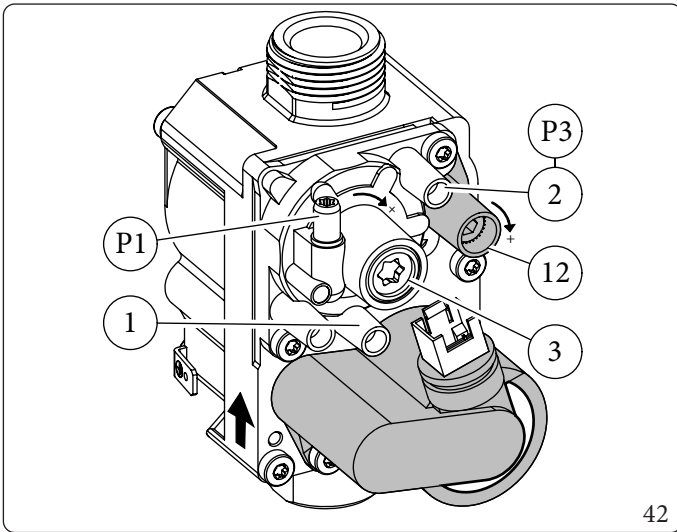

42

Key (Fig. 42):

- 1 - Gas valve inlet pressure point
- 2 - Gas valve outlet pressure point
- 3 - Off/Set adjustment screw
- 12 - Outlet gas flow rate adjuster

SIT 848 GAS Valve

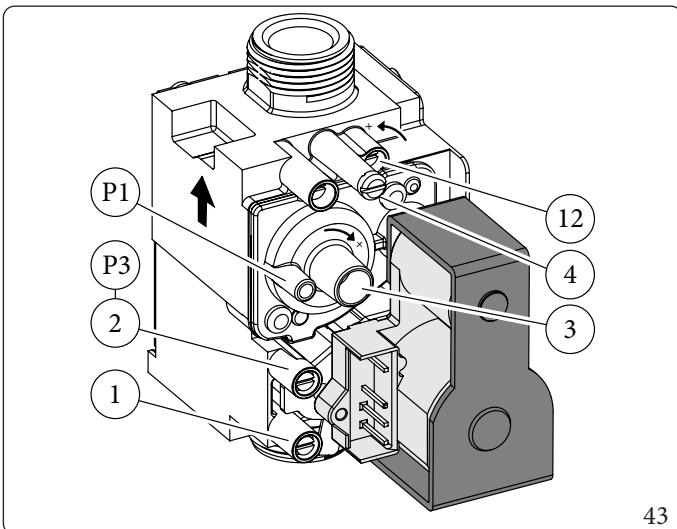

43

Key (Fig. 43):

- 1 - Gas valve inlet pressure point
- 2 - Gas valve outlet pressure point
- 3 - Off/Set adjustment screw
- 4 - Pressure regulator connection (PR)
- 12 - Outlet gas flow rate adjuster

INSTALLER

USER

MAINTENANCE TECHNICIAN

TECHNICAL DATA

3.8 FAN SPEED CALIBRATION



Verification and calibration are necessary, in the case of transformation to other types of gas, in the extraordinary maintenance phase with replacement of the PCB, air/gas circuit components or in the case of installations with flue extraction systems, with horizontal concentric pipe measuring more than 1 metre.

The appliance's heat output is correlated to the length of the air intake and flue exhaust pipes.

This decreases with the increase of pipe length.

The appliance leaves the factory adjusted for minimum pipe length (1m coaxial).

- Activate flue test (Par. 3.15);
- Detect the flue signal ΔP (Ref. 17 and 18, Fig. 40);
- When replacing the P.C.B. or adapting to another type of gas, set parameters "S0" and "S2" as indicated in the table in the paragraph "3.11 P.C.B. programming" and parameter "S1" as indicated in the table below.
- When replacing the P.C.B. or adapting to another type of gas, set the heating output (parameter "P2") as shown in the table in the paragraph "3.11 P.C.B. programming".

Victrix Tera V2 28 EU

	$\Delta P < 153 \text{ Pa}$	$\Delta P \geq 153 \text{ Pa}$	$\Delta P \geq 215 \text{ Pa}$
G20 (x50 = RPM)	S1 = 118	S1 = 121	S1 = 124
G31 (x50 = RPM)	S1 = 118	S1 = 121	S1 = 124

Victrix Tera V2 32 EU

	$\Delta P < 213 \text{ Pa}$	$\Delta P \geq 213 \text{ Pa}$	$\Delta P \geq 300 \text{ Pa}$
G20 (x50 = RPM)	S1 = 122	S1 = 126	S1 = 130
G31 (x50 = RPM)	S1 = 122	S1 = 126	S1 = 130

Victrix Tera V2 38 EU

	$\Delta P < 295 \text{ Pa}$	$\Delta P \geq 295 \text{ Pa}$	$\Delta P \geq 383 \text{ Pa}$
G20 (x50 = RPM)	S1 = 120	S1 = 123	S1 = 126
G31 (x50 = RPM)	S1 = 120	S1 = 123	S1 = 126

3.9 CO₂/O₂ REGULATION



The verification operations of the CO₂/O₂ must be carried out with the casing mounted, while the gas valve calibration operations must be carried out with the casing open and removing the voltage from the appliance.



The calibrations described below must be carried out in the correct sequence and more precisely, first the calibration of the CO₂/O₂ at maximum output and then the calibration of the CO₂/O₂ at minimum output.

- PX42 Gas Valve

Calibration of the CO₂ at maximum output

Enter the chimney sweep mode without withdrawing DHW and set the output to maximum (99%).

To have an exact value of CO₂ in the flue, the technician must insert the sampling probe to the bottom of the sample point, then check that the CO₂ value is that specified in the table (Ref. Par. 4.2), otherwise adjust the screw (Part. 12, Fig. 42) (gas flow rate regulator).

To increase the CO₂ value, turn the adjustment screw (Part. 12, Fig. 42) clockwise and vice-versa to decrease it.

At every adjustment variation on the screw (Part. 12, Fig. 42), it is necessary to wait for the boiler to stabilise itself at the value set (about 30 sec.).

Calibration of the CO₂ at minimum output

After setting the CO₂ to maximum power while keeping the chimney sweep function active and without drawing domestic water, set the output to minimum (0%).

To have an exact value of CO₂ in the flue, the technician must insert the sampling probe to the bottom of the sample point, then check that the CO₂ value is that specified in the table (Ref. Parag. 4.2), otherwise adjust the screw (Part. 3, Fig. 42) (Off-Set regulator) after removing the cover cap.

To increase the CO₂ value, turn the adjustment screw (Part. 3, Fig. 42) clockwise and vice-versa to decrease it.



In the case where the calibration refers to O₂ the adjustment logic is reversed from the above for CO₂.

- Gas Valve 848

Calibration of the CO₂ at maximum output

Enter the chimney sweep mode without withdrawing DHW and set the output to maximum (99%).

To have an exact value of CO₂ in the flue, the technician must insert the sampling probe to the bottom of the sample point, then check that the CO₂ value is that specified in the table (Ref. Par. 4.2), otherwise adjust the screw (Part. 12, Fig. 43) (gas flow rate regulator).

To increase the CO₂ value, turn the adjustment screw (Part. 12, Fig. 43) anticlockwise and vice-versa to decrease it.

At every adjustment of the adjustment screw (Det. 12, Fig. 43), it is necessary to wait for the boiler to stabilise itself at the value set (about 30 sec.).

Calibration of the CO₂ at minimum output

After setting the CO₂ to maximum power while keeping the chimney sweep function active and without drawing domestic water, set the output to minimum (0%).

To have an exact value of CO₂ in the flue, the technician must insert the sampling probe to the bottom of the sample point, then check that the CO₂ value is as specified in the table (Ref. Par. 4.2), otherwise adjust the screw (Part. 3, Fig. 43) (Off-Set controller) after removing the cover cap.

To increase the CO₂ value, turn the adjustment screw (Part. 3, Fig. 43) clockwise and vice-versa to decrease it.



In the case where the calibration refers to O₂ the adjustment logic is reversed from the above for CO₂.

3.10 CHECKS FOLLOWING CONVERSION TO ANOTHER TYPE OF GAS

After making sure that conversion was carried out with a nozzle of suitable diameter for the type of gas used and the settings are made at the correct pressure, check that the burner flame is not too high or low and is stable (does not detach from burner).



Maintenance operations must be carried out by an authorised company (e.g. Authorised After-Sales Technical Assistance Centre).

3.11 P.C.B. PROGRAMMING

The device is prepared for possible programming of several operation parameters. By modifying these parameters as described below, the device can be adapted according to specific needs.

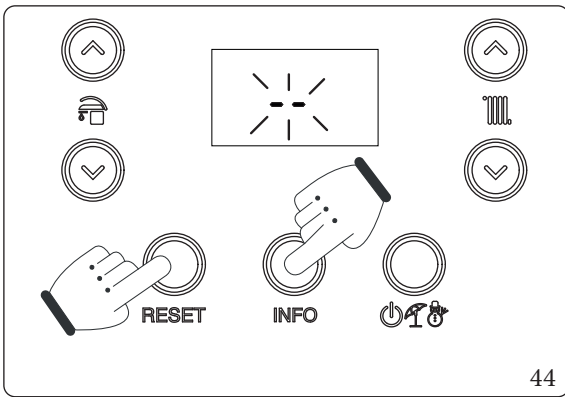

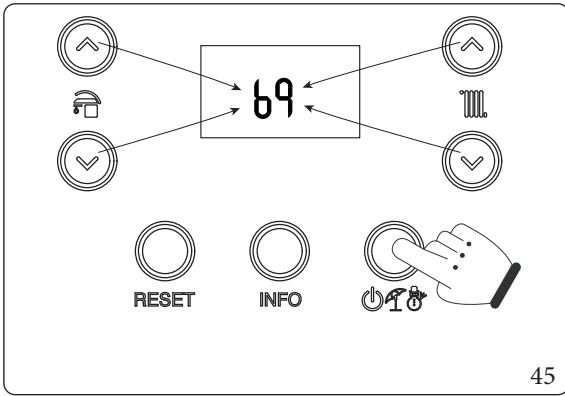

To access the programming phase, press and hold the buttons “RESET” and “INFO” for more than 5 seconds; the display shows two dashes “--” flashing and you must enter the password to access the programming menus.

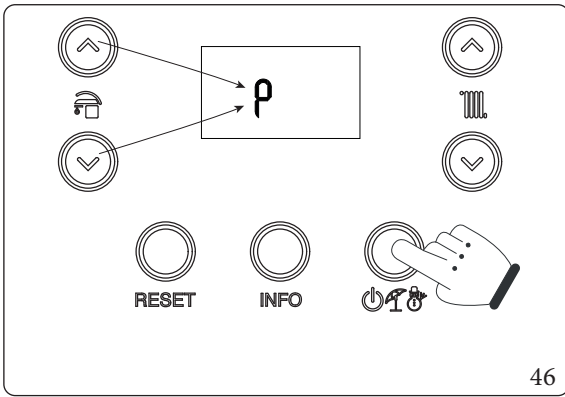

To enter the first digit use the buttons to adjust the DHW “”, to enter the second digit use the buttons to adjust the central heating temperature “”. To confirm the password (69) and access the menu, press the operating mode button “”.



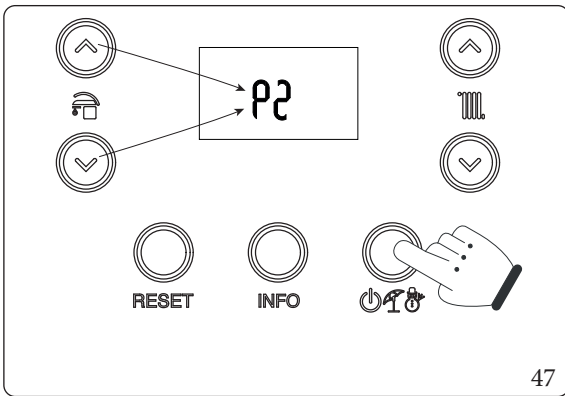

Once in the menu, you can cyclically scroll the four submenus (P, t, A, S) by pressing the DHW “”, to access the menu press the button “”.

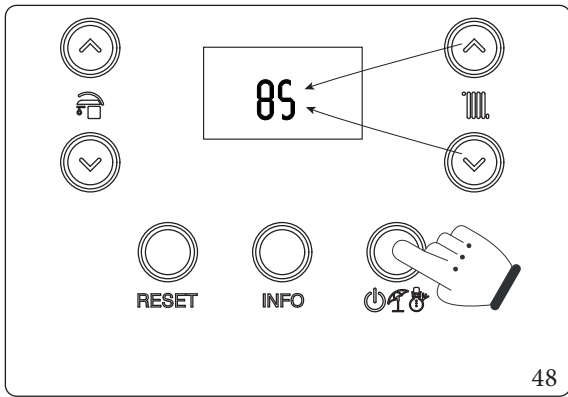

The first digit of the central indicator (Fig. 39) shows the family of the parameter, while the second digit shows its number.





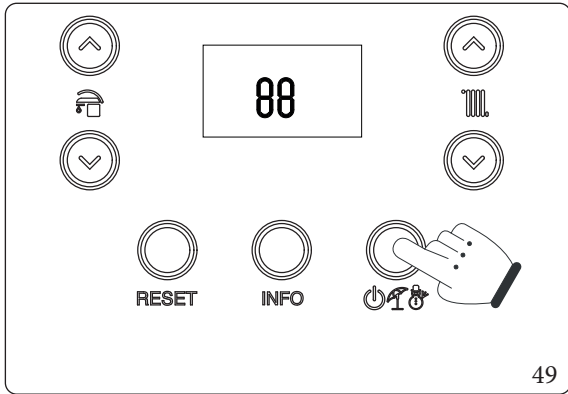



Pressing the mode of operation button “” displays the value of the selected parameter and by pressing the buttons to adjust the central heating temperature “” you can adjust its value.



Press the mode of operation button “” for more than 1 second to store the parameter value; confirmation is given by the word “**88**” which appears for 2 seconds.

If you want to exit a parameter without changing its value, press the button “RESET”.
Wait for 15 minutes or press the “RESET” button to exit programming mode.

Programming phase sequence							
RESET + INFO > 5"	Menu "P", "t", "A", "S" 	< RESET 	P0 - P5 t0 - t9 A0 - A6 S0 - S2 	< RESET 	Parameter value 	< RESET (without memorising)  > 1" (Memorise)	88

Id Parameter	Parameter	Description	Range	Default	Customised value
P0	Max DHW output	Defines the maximum heat output percentage of the boiler during the D.H.W. phase compared to the maximum heat output available	0 - 100 %	100 %	
P1	Min CH output	Defines the minimum output percentage of the boiler in central heating mode	0 - P2	0 %	
P2	Max CH output	Defines the maximum heat output percentage of the boiler during the central heating mode compared to the maximum heat output available	0 - 100 %	VICTRIX TERA V2 28 EU	
				G20 = 83	
				G31 = 83	
				VICTRIX TERA V2 32 EU	
				G20 = 86	
				G31 = 86	
				VICTRIX TERA V2 38 EU	
G20 = 86					
G31 = 86					
P3	-	Not available for this model	-	-	
P4	Pump functioning	The pump can function in two ways. 0 intermittent: in winter "mode" the circulator is managed by the room thermostat or by the remote control. 1 continuous: in "winter" mode the circulator is always powered and is therefore always in operation.	0 - 1	0	
P5	External probe correction	If the reading of the external probe is not correct it is possible to correct it in order to compensate any environmental factors.	-9 ÷ 9 K	0	
P6	-	Not available for this model	-	-	
P7	Remote control	Sets the dialogue protocol with the remote device 0: IMGBUS. Select this mode when connecting an Immergas remote control (e.g. CARv2) to terminals 44-41 1: Not available on this model 2: Select this mode when a commercial remote control is connected to terminals 44-41 (with this selection, the control of the domestic hot water adjustments and max set central heating flow remains available on the boiler panel)	0 - 2	0	
P8	-	Not available for this model	-	-	

Id Parameter	Parameter	Description	Range	Default	Customised value
t0	Central heating set point minimum temperature	Defines the minimum flow temperature.	20 ÷ 50 °C	25	
t1	Central heating set point maximum temperature	Defines the maximum flow temperature.	(t0+5) ÷ 85 °C	85	
t2	Solar delay timing	The boiler is set to switch-on immediately after a request for DHW. In the case of coupling with a solar storage tank positioned upstream from the boiler, it is possible to compensate the distance between the storage tank and the boiler in order to allow the water to reach the boiler. Set the time necessary to verify that the water is hot enough (see par. Solar panels coupling).	0 - 30 seconds	0	
t3	D.H.W. priority timing	In winter mode the boiler, at the end of a domestic hot water request, is ready to switch to central heating mode if there is an active request. Timing sets a time period in which the boiler waits before changing the operating mode, in order to quickly and comfortably satisfy an additional request for domestic hot water.	0 - 100 seconds (step 10 sec)	2	
t4	Central heating ignitions timer	The boiler has an electronic timer, which prevents the burner from igniting too often in central heating mode.	0 - 600 seconds (step 10 sec)	18	
t5	Heating ramp timing	In central heating mode, the boiler performs an ignition ramp in order to reach the maximum output set.	0 - 840 seconds (step 10 sec)	18	
t6	CH ignition delay from TA and CR request	The boiler is set to switch-on immediately after a request. In the event of particular systems (e.g. area systems with motorised thermostatic valves etc.) it may be necessary to delay ignition	0 - 600 seconds (step 10 sec)	0	
t7	Display lighting	Establishes the display lighting mode. 0: the display lights up during use and lowers after 15 seconds of inactivity. In the case of anomaly the display flashes. 1: display lighting off. 2: the display is always lit up.	0 - 2	0	

INSTALLER

USER

MAINTENANCE/TECHNICIAN

TECHNICAL DATA

Id Parameter	Parameter	Description	Range	Default	Customised value
t8	Display	Establishes what the indicator displays (Fig. 39). "Summer" mode: 0: the indicator is always off. 1: pump active displays the flow temperature, pump off the indicator is off. "Winter" mode: 0: it always displays the value set on the central heating selector. 1: circulator pump active displays the flow temperature, pump off displays the value set on the central heating selector.	0 - 1	1	
t9	Flow off temperature increase	Increases the flow off temperature at ignition only in the first 60 seconds. After the flame is detected, the temperature is increased by t9.	0 - 15	0	

Id Parameter	Parameter	Description	Range	Default	Customised value
A0	Hydraulic model	Defines the type of hydraulics in the boiler (0 = instant; 1 = storage tank).	0 ÷ 1	0	
A1	Maximum pump speed	Defines the maximum operating speed of the circulator (If A1 = A2 circulator operating at set speed).	A2 - 9	9	
A2	Minimum pump speed	Defines the minimum operating speed of the circulator.	1 - A1	6	
A3	Circulating pump mode	Sets the pump operating mode DELTA T = 0: proportional head (Par.. 1.29). - DELTA T = 5 - 25 K: ΔT constant (Par.. 1.29)	0 ÷ 25	15	
A4	Storage tank flow offset	Not available for this model	-	-	
A5	Storage tank activation offset	Not available for this model	-	-	
A6	D.H.W. thermostat	Establishes the switch-off method in DHW mode. 0 Fixed: the switch-off temperature is fixed at the maximum value regardless of the value set on the control panel. 1 Correlated: the boiler switches off according to the temperature set.	0 ÷ 1	0	

Victrix Tera V228 EU

Id Parameter	Parameter	Description	Range	Default	Customised value
S0	DHW minimum no. of fan revs	Defines the operating speed of the fan at minimum DHW output	20 - 60 (x 50 = RPM)	27 (G20)	
				27 (G31)	
S1	DHW maximum no. of fan revs	Defines the operating speed of the fan at maximum DHW output	50 - 140 (x 50 = RPM)	118 (G20)	
				118 (G31)	
S2	Ignition phase no. of fan revs	Defines the operating speed of the fan during the ignition phase	40 - 80 (x 50 = RPM)	44 (G20)	
				44 (G31)	

Victrix Tera V232 EU

Id Parameter	Parameter	Description	Range	Default	Customised value
S0	DHW minimum no. of fan revs	Defines the operating speed of the fan at minimum DHW output	20 - 60 (x 50 = RPM)	28 (G20)	
				28 (G31)	
S1	DHW maximum no. of fan revs	Defines the operating speed of the fan at maximum DHW output	50 - 140 (x 50 = RPM)	122 (G20)	
				122 (G31)	
S2	Ignition phase no. of fan revs	Defines the operating speed of the fan during the ignition phase	40 - 80 (x 50 = RPM)	50 (G20)	
				50 (G31)	

Victrix Tera V238 EU

Id Parameter	Parameter	Description	Range	Default	Customised value
S0	DHW minimum no. of fan revs	Defines the operating speed of the fan at minimum DHW output	20 - 60 (x 50 = RPM)	27 (G20)	
				27 (G31)	
S1	DHW maximum no. of fan revs	Defines the operating speed of the fan at maximum DHW output	50 - 140 (x 50 = RPM)	120 (G20)	
				120 (G31)	
S2	Ignition phase no. of fan revs	Defines the operating speed of the fan during the ignition phase	40 - 80 (x 50 = RPM)	56 (G20)	
				56 (G31)	

INSTALLER

USER

MAINTENANCE TECHNICIAN

TECHNICAL DATA

3.12 PASSWORD-PROTECTED SPECIAL FUNCTIONS



The appliance is equipped with some special functions, access to which is granted if this is in stand-by (⏻).



If the appliance is connected to the CAR^{V2}, the “stand-by” function is only obtained via the remote control panel.

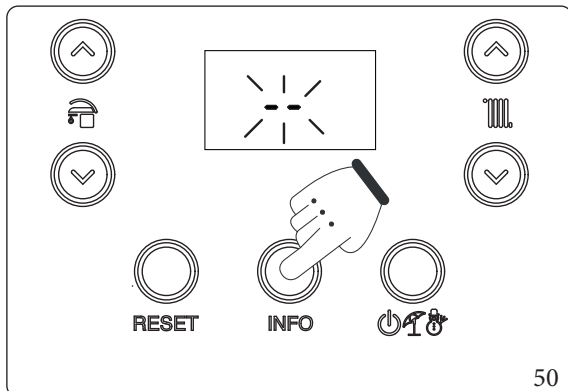

Press and hold the “INFO” button for more than 5 seconds.
The display will show two dashes “--” flashing.
Now enter the password to access the programming menus.

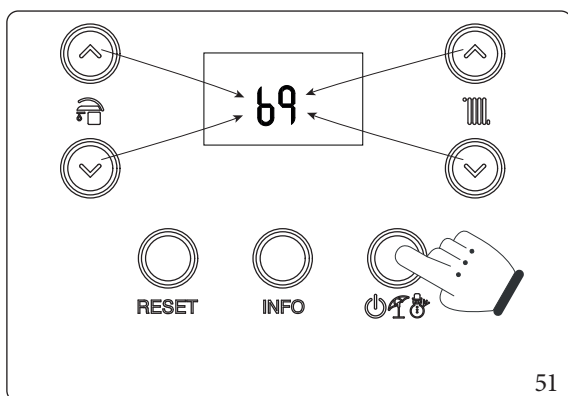

To enter the first digit use the buttons to adjust the DHW “

”, to enter the second digit use the buttons to adjust the central heating temperature “

”. To confirm the password (69) and access the menu, press the operating mode button “

Once the menu has been accessed, it is possible to cyclically scroll the three available functions (dl, MA, FU) by pressing the DHW buttons “

”, to access the menu press the button “

” to exit wait 15 minutes or press the button “RESET”.

3.13 SCREED HEATER FUNCTION

The appliance is equipped with a function to perform the thermal shock on new radiant panel systems, as required by the applicable standard.



Contact the manufacturer of the radiant panels for the thermal shock characteristics and its correct execution.



To be able to activate the function there must be no remote control connected, while in case of system divided into zones it must be properly connected, both hydraulically and electrically.

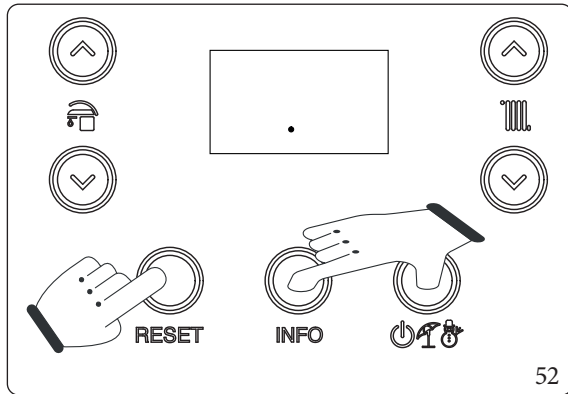

The function is activated from boiler in “off” by pressing and holding the “RESET”, “INFO” and “ON/OFF” buttons for more than 5 seconds.

The function lasts in total 7 days, 3 days at the lower temperature set and 4 days at the higher temperature set (Fig. 53). After activating the function, the lower set (range 20 ÷ 45 °C default = 25 °C) and the higher set (range 25 ÷ 55 °C default = 45 °C) appear in sequence.

The temperature is selected by means of the buttons “UP” and confirmed by pressing the button “ON/OFF”.

The display now shows the countdown of days alternated with the current flow temperature, as well as the normal operating symbols of the boiler.

In case of failure or lack of supply voltage, the function is suspended and will resume when the normal operating conditions are reset from the point where it was interrupted.

When the time expires, the boiler automatically goes back to “Stand-by” mode, the function can also be stopped by pressing the button “ON/OFF”.

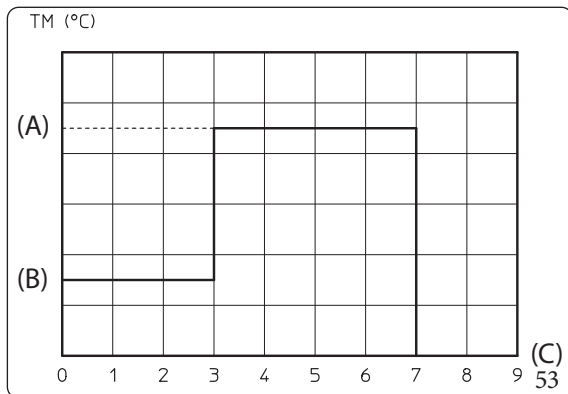

Key (Fig. 53):

(A) - Top set

(B) - Lower set

(C) - Days

TM - Flow temperature

3.14 AUTOMATIC VENT FUNCTION (DL)

In the case of new central heating systems and in particular mode for floor systems, it is very important that deaeration is performed correctly. The function consists of the cyclic activation of the pump (100 s ON, 20 s OFF) and the 3-way valve (120 s D.H.W., 120 s C.H.).

The function is activated by accessing the special “dl” function as described in the Paragraph 3.12.

The function lasts for 16.5 hours and it can be stopped by simply pressing the button “RESET”.

Activation of the function is signalled by the countdown shown on the indicator (Fig. 39).



3.15 FLUE INSTALLATION (FU)

To activate the “Flue” function access the special functions as described in Paragraph 3.12 and select the “FU” function.



Before performing the test, ensure that the condensate drain trap has been filled correctly and check that there are no obstructions in the air intake circuit and flue exhaust and that the sealed chamber is perfectly closed and the flue has already been installed.

Using this function activates the fan at a fixed speed (6000 rpm) for 15 minutes.

In this phase the symbols () and () are displayed flashing, while the symbol () is displayed permanently on, the function can be stopped by simply pressing the button “RESET”.





3.16 MAINTENANCE FUNCTION (MA)

Using this function, you can activate some operating devices of the appliance without starting it, thus verifying operation.

The function is active for 15 minutes and it can be stopped by pressing the button “RESET”.

To activate the “Maintenance” function, access the special functions as described in Paragraph 3.12 and select the “MA” function.

The following loads can be activated within this function:

- Fan (Fn): the fan is brought to ignition speed. Using the buttons “  ” you can increase or decrease the fan speed.
- Circulator (Pu): the circulator is brought to maximum speed, the relative speed is shown on the display, using the buttons “  ” you can increase or decrease the circulator speed.
- Three-way (3d): the symbol is shown on the display according to the position of the valve, DHW () or central heating (), using the buttons “  ” you can change the valve position, taking care to wait for the completion of passage between statuses.
- Configurable relay (rl): the configurable relay in the boiler is energised.

3.17 CHIMNEY SWEEP FUNCTION

When activated, this function forces the boiler to variable output for 15 minutes.

In this state all adjustments are excluded and only the safety thermostat and the limit thermostat remain active.

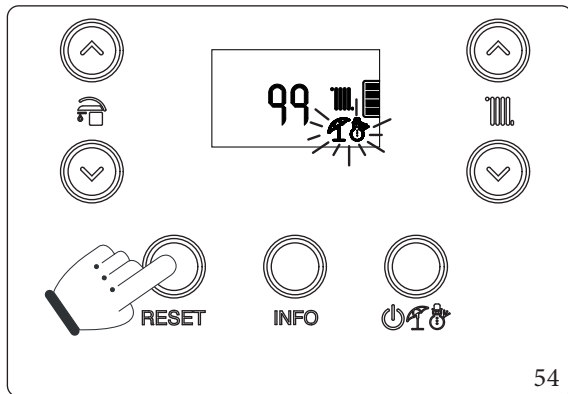

To activate the chimney sweep function, press the “RESET” button until activation of the function in the absence of DHW requests.

Its activation on the boiler display is confirmed by the indicators flashing at the same time (Fig. 39).

This function allows the technician to check the combustion parameters.

Once the function is activated, it is possible to select whether to make the check in CH status or DHW status by opening any hot water cock.

Using the buttons “” you can select between three predefined power levels:

- “0%”;
- Max CH output (P2);
- Max DHW output (P0).

While by using the buttons “” you can select the power from 0% to max DHW output (P0), with intervals of 1%.

The central heating or DHW operating mode is displayed by the relative symbols “” or “”.

After the checks, deactivate the function by switching the boiler off and then back on again.

3.18 SOLAR PANELS COUPLING FUNCTION

The device is set up to receive pre-heated water from a system of solar panels up to a maximum temperature of 65°C. In any case, it is always necessary to install a mixing valve on the hydraulic circuit upstream of the device, on the cold water inlet.

To optimise the operation, where the probe is not already fitted on the boiler, the solar inlet probe kit is available on request (see wiring diagram Fig. 41):

- If there is no probe kit, it is advisable to set parameter A6 (DHW thermostat) at "1";
- Otherwise, where the kit is installed or the probe is already present in the boiler, parameter A6 must be left at "0". This kit allows connecting a probe on the domestic cold water inlet pipe of the boiler to prevent unnecessary ignitions in systems with water heating through solar systems or alternative sources. The boiler will not turn on if the inlet water is sufficiently hot.

In both conditions (probe present or not), we recommend setting parameter t3 (solar delay timing) at a time sufficient to let the water inside the D.H.W. circuit upstream of the boiler drain.

The greater the distance from the storage tank, the longer wait time will have to be set.

With these adjustments made, when a domestic withdrawal is requested, once the time set on parameter "t3" has passed, if the water entering the boiler is at a temperature that is equal to or greater than that set, the boiler will not turn on.



For good functioning of the boiler; the temperature selected on the solar valve must be 5 °C greater with respect to the temperature selected on the boiler control panel.

3.19 PUMP ANTI-BLOCK FUNCTION

The appliance has a function that starts up the pump at least once every 24 hours for 30 seconds in order to reduce the risk of the pump locking up due to prolonged inactivity.

3.20 THREE-WAY ANTI-BLOCK SYSTEM

In both phase "Domestic Hot Water" and "Domestic Hot Water-Central Heating", the appliance has a function that activates the motorised 3-way unit 24 hours after the last time it operated by running a complete cycle in order to reduce the risk of the 3-way blocking due to prolonged inactivity.

3.21 RADIATORS ANTIFREEZE FUNCTION

If the system return water is below 4°C, the appliance starts up until reaching 42°C.

3.22 CASINGREMOVAL

To facilitate appliance maintenance the casing can be completely removed as follows:

Lower grid (Fig. 55)

- Loosen the two screws (a);
- Press the hooks inwards, which block the lower grid (b).
- Remove the grid (b).

Front casing (Fig. 56)

- Loosen the screws (c).
- Pull the front casing (d) towards yourself from the underside to release it from the control panel.
- Lift the front casing and remove it from the upper pins (e).



To reattach the front, proceed in reverse order, taking care to press around the area of the keys to reattach the front.

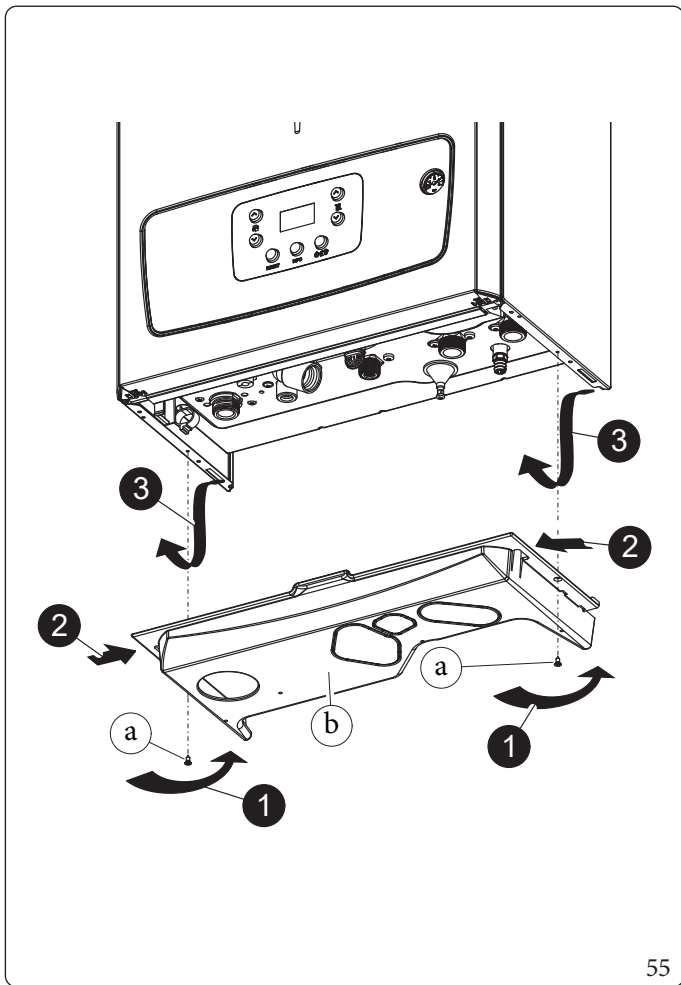

55

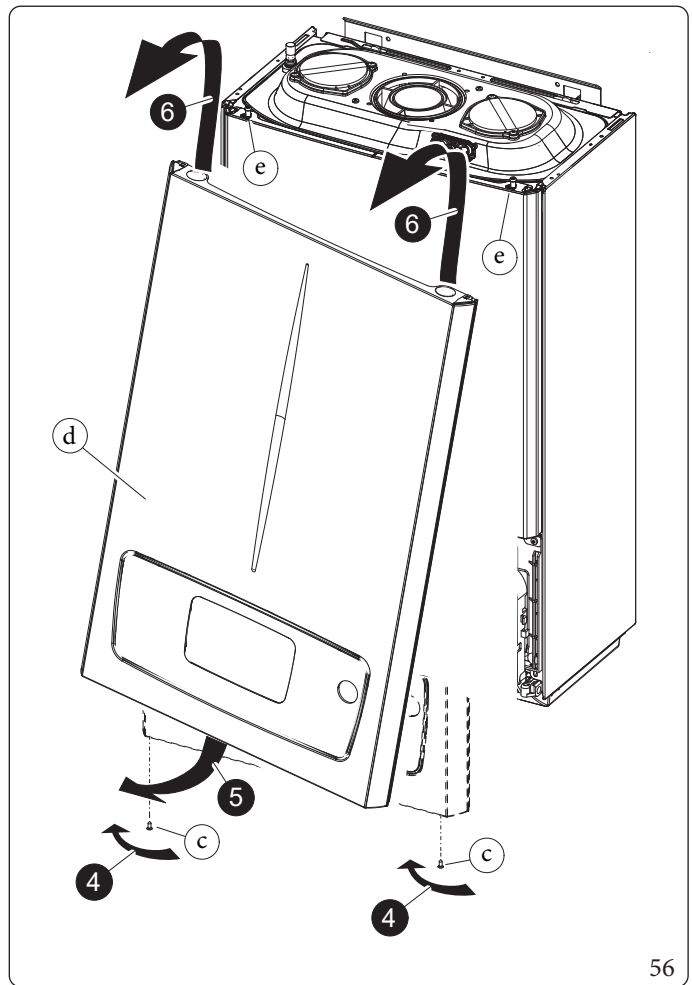

56

INSTALLER

USER

MAINTENANCE/TECHNICIAN

TECHNICAL DATA

Insulating panel (Fig. 57)

- Unscrew the two screws (g) at the bottom of the sealed chamber cover (f).
- Pull the sealed chamber cover (f) slightly towards yourself.
- Release the sealed chamber cover (f) from the pins (h) by pulling it towards yourself while pushing it upwards.

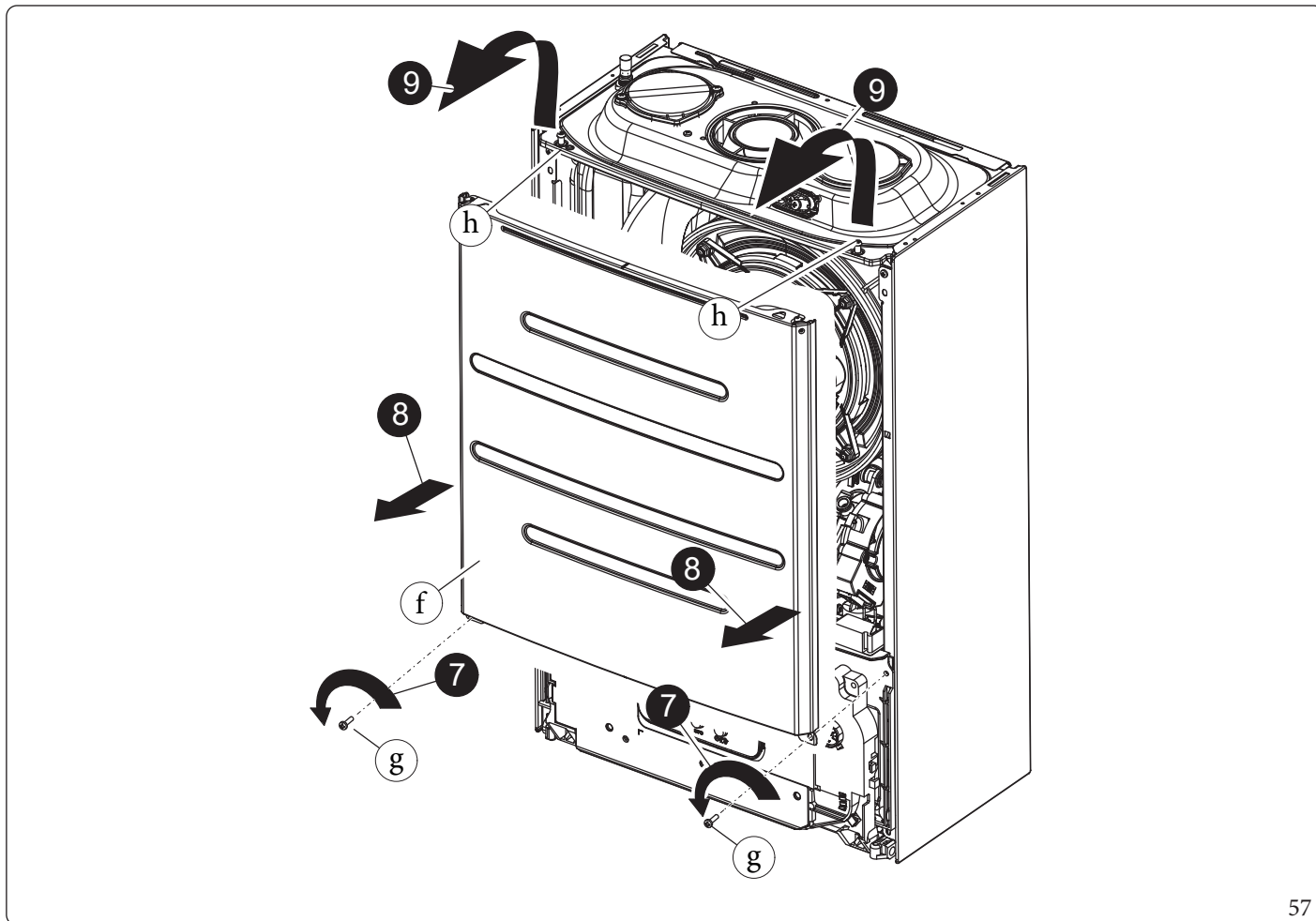

Control panel (Fig. 58)

- Press the hooks on the side of the control panel (i).
- Tilt the control panel (i) towards you.

Sides (Fig. 59)

- Loosen screws (k) of side fastening (j).
- Remove the sides by extracting them from their rear seat (Ref. X).

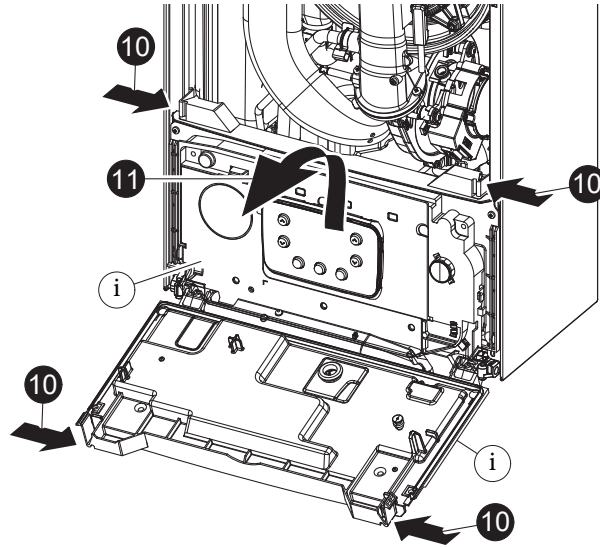

58

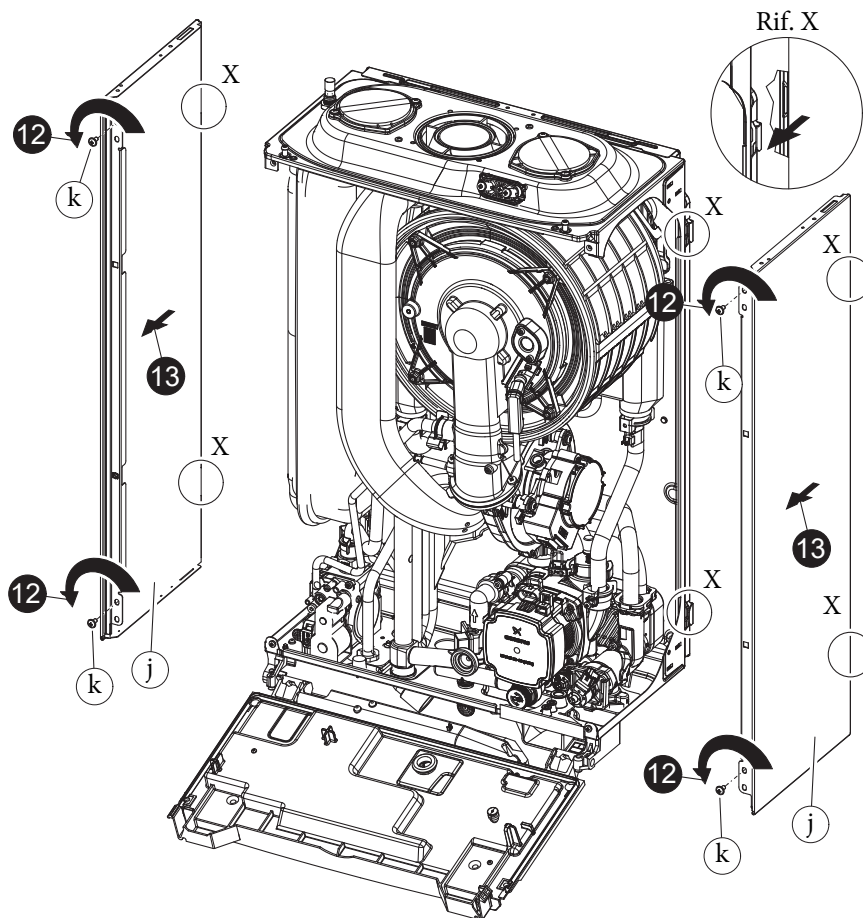

59

INSTALLER

USER

MAINTENANCE/TECHNICIAN

TECHNICAL DATA

3.23 REPLACING THE MANIFOLD INSULATING PANEL



The operations described below must be performed after having removed the voltage from the appliance.

Victrix Tera V2 28 EU - V2 32 EU

1. To access the inside of the appliance, remove the casing as indicated in Paragr. 3.22.
2. Unscrew the 4 manifold fastening nuts (1, Fig. 66) and gently pull them out orthogonally towards yourself.
3. Unscrew the fixing screws (6) of the ignition and detection electrode (5) and remove it.
4. Remove the insulating panel (1) by actuating a blade (2) under its surface.
5. Remove the residue of the fixing adhesive from the surface of the manifold (3).
6. Replace the insulating panel (1).



The new insulating panel, used as a spare to replace the removed one, does not need to be fixed with glue as its shape with the interference on the burner ensures correct coupling with the manifold.

7. Refit the ignition and detection electrode (5) using the previously removed screws (6) and replace the relative gasket (4).

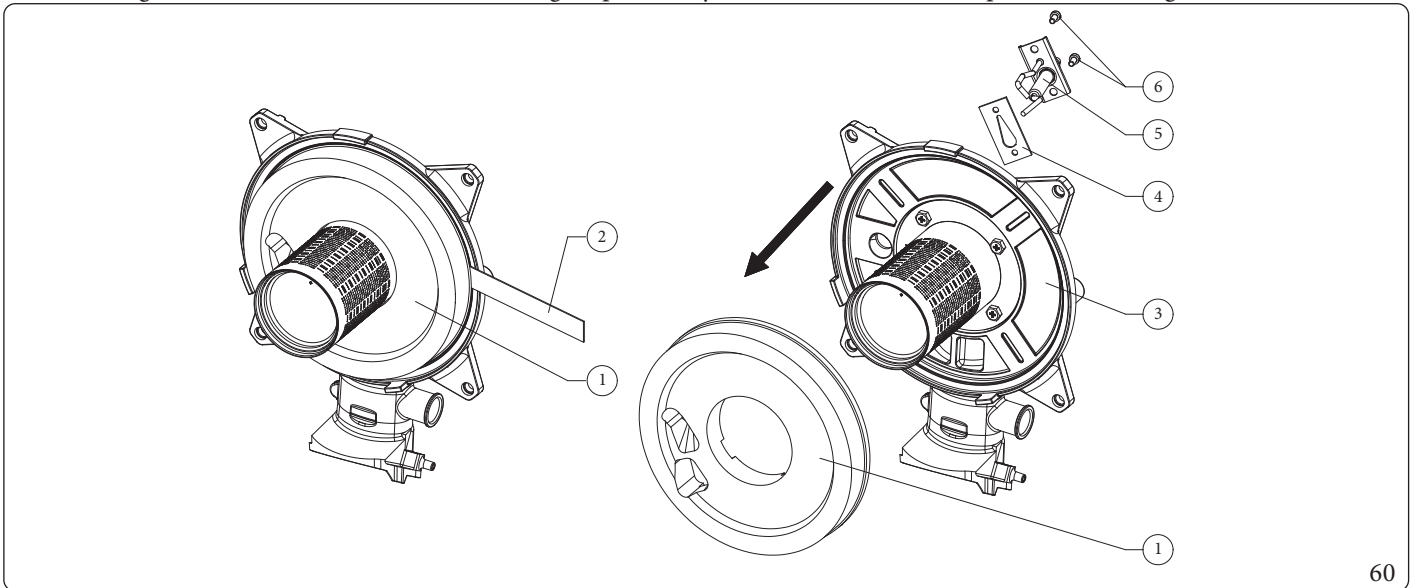

60

Electrode distance

To regain optimal operation, make sure that the following variables are respected when refitting the electrodes.

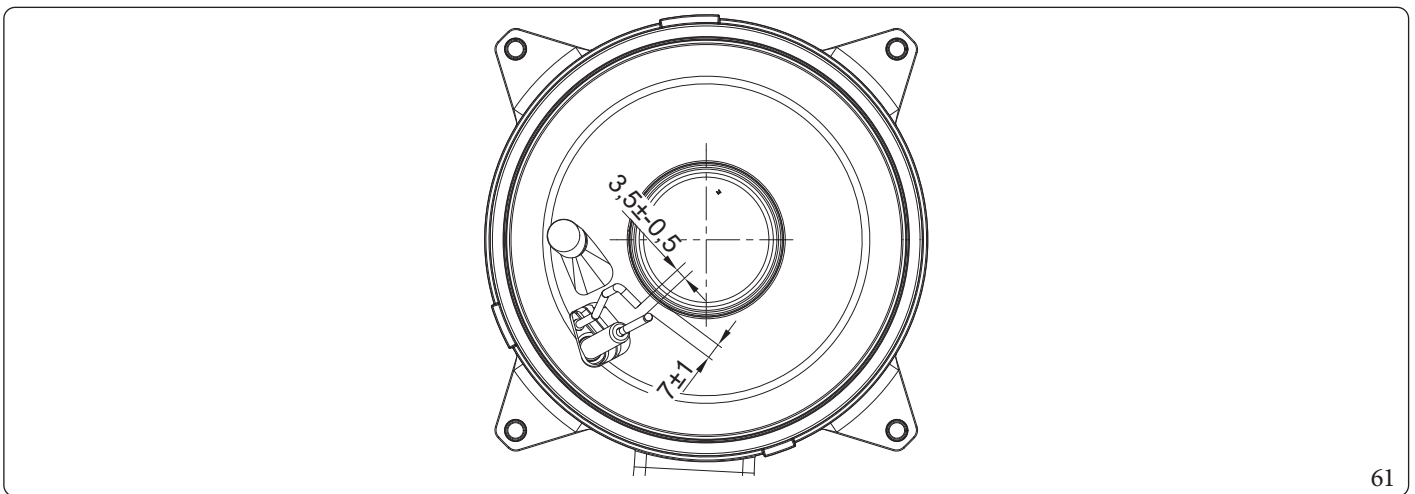

61

Victrix Tera V238 EU

1. To access the inside of the appliance, remove the casing as indicated in Paragr. 3.22.
2. Unscrew the 4 manifold fastening nuts (1, Fig. 67) and gently pull them out orthogonally towards yourself.
3. Unscrew the fixing screws (6) of the ignition and detection electrode (5) and remove it.
4. Insert the tip of a flat-blade screwdriver (10) into the groove (12) of the 3 clips (2) of the insulating fastener. Lever the retaining tongue (2) out of its seat (11) and pull it out.
5. Replace the insulating panel (1) and secure it with the 3 clips (2) which were previously removed: insert them under the relevant screws (7) and push them until the retaining tab (2) snaps into its seat (11) on the manifold.
6. Check the condition of the gaskets (8) and (9) and replace them if necessary after removing them from their seats as described in Paragr. 3.24.
7. Refit the ignition and detection electrode (5) using the previously removed screws (6) and replace the relative gasket (4).

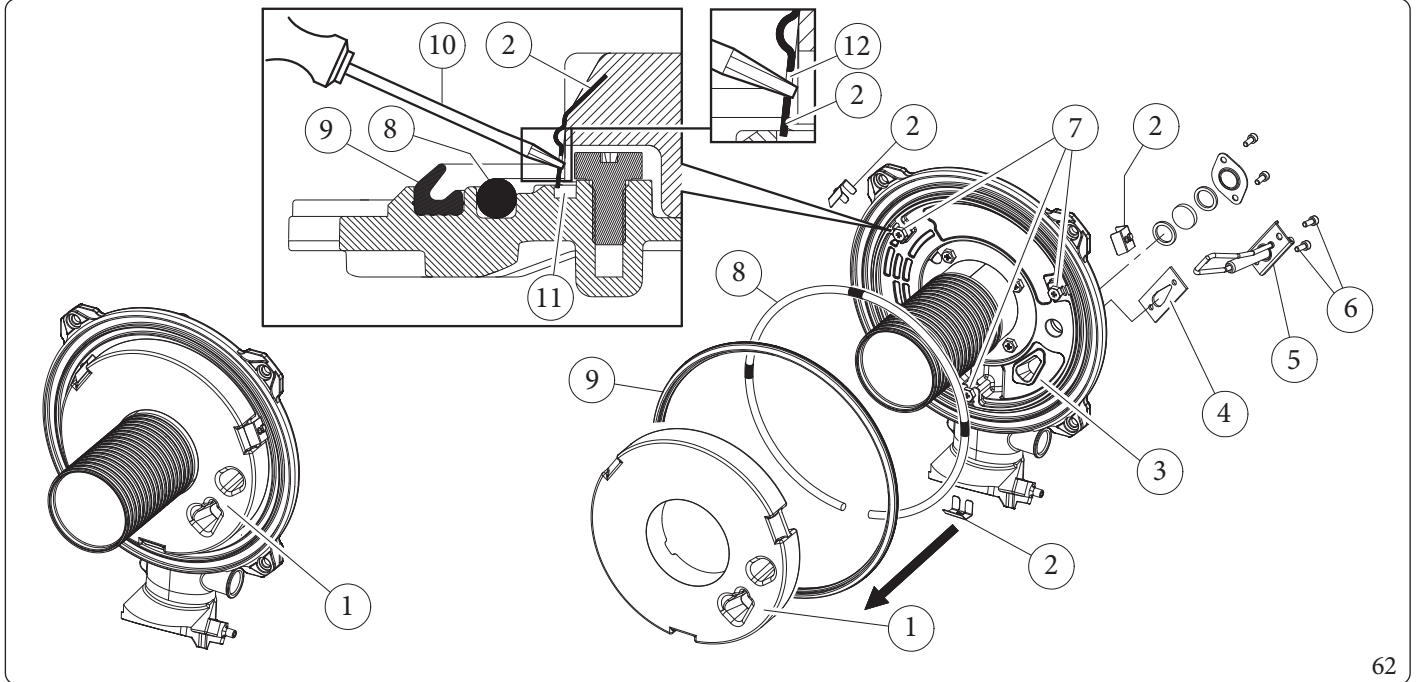

62

Electrode distance

To regain optimal operation, make sure that the following variables are respected when refitting the electrodes.

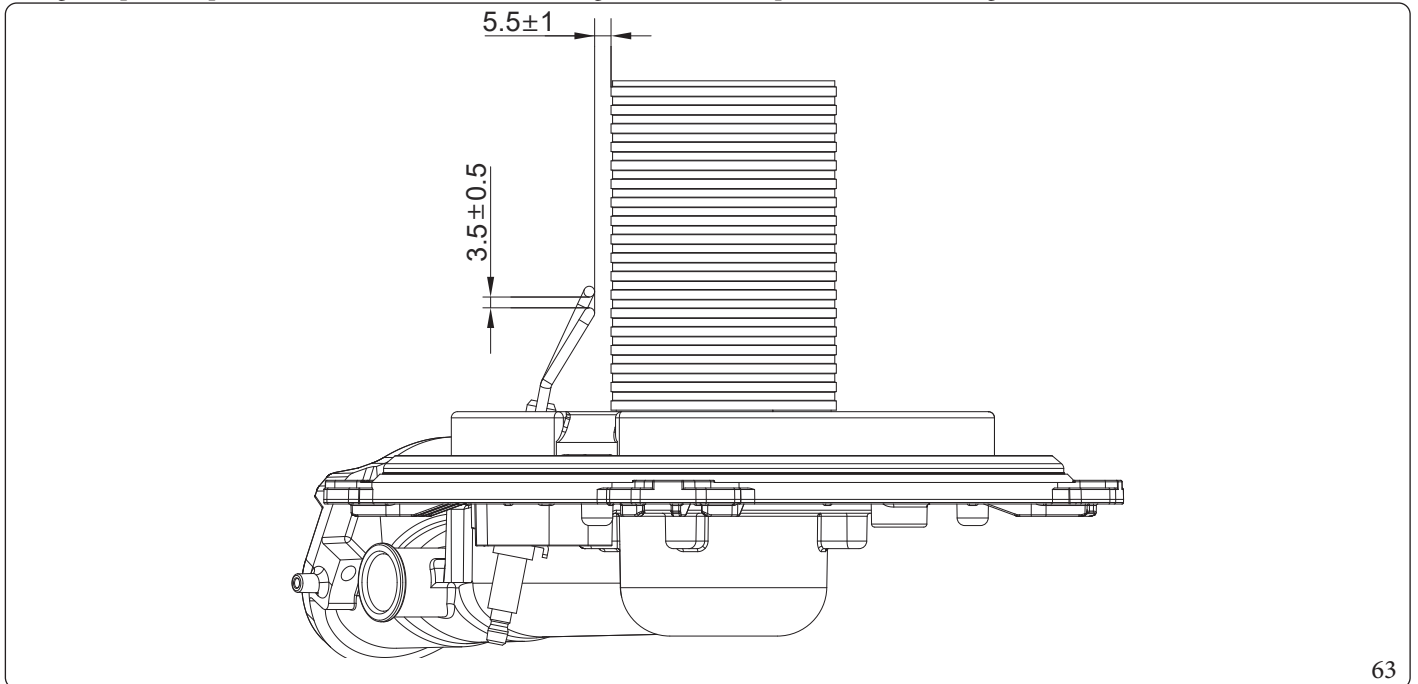

63

INSTALLER

USER

MAINTENANCE/TECHNICIAN

TECHNICAL DATA

3.24 REPLACING MANIFOLD SEALS



The operations described below must be performed after having removed the voltage from the appliance.

After checking the integrity of the seals, proceed as follows if they need to be replaced:

Victrix Tera V2 28 EU - V2 32 EU

1. Remove old seals.
2. Place the module gasket (1) radially on the edge of the condensation module flange (2).
3. Make sure that the gasket tab with number 4 printed on it is positioned in its seat on the module flange, identified by the number 4.



Every time the manifold is opened, the condition and integrity of the ceramic fibres must be verified and replaced, if necessary. On the other hand, the manifold gasket must be replaced every 2 years and every time the manifold is opened, regardless of the time elapsed. After replacing the external silicone gasket, it is mandatory to check the fume tightness.

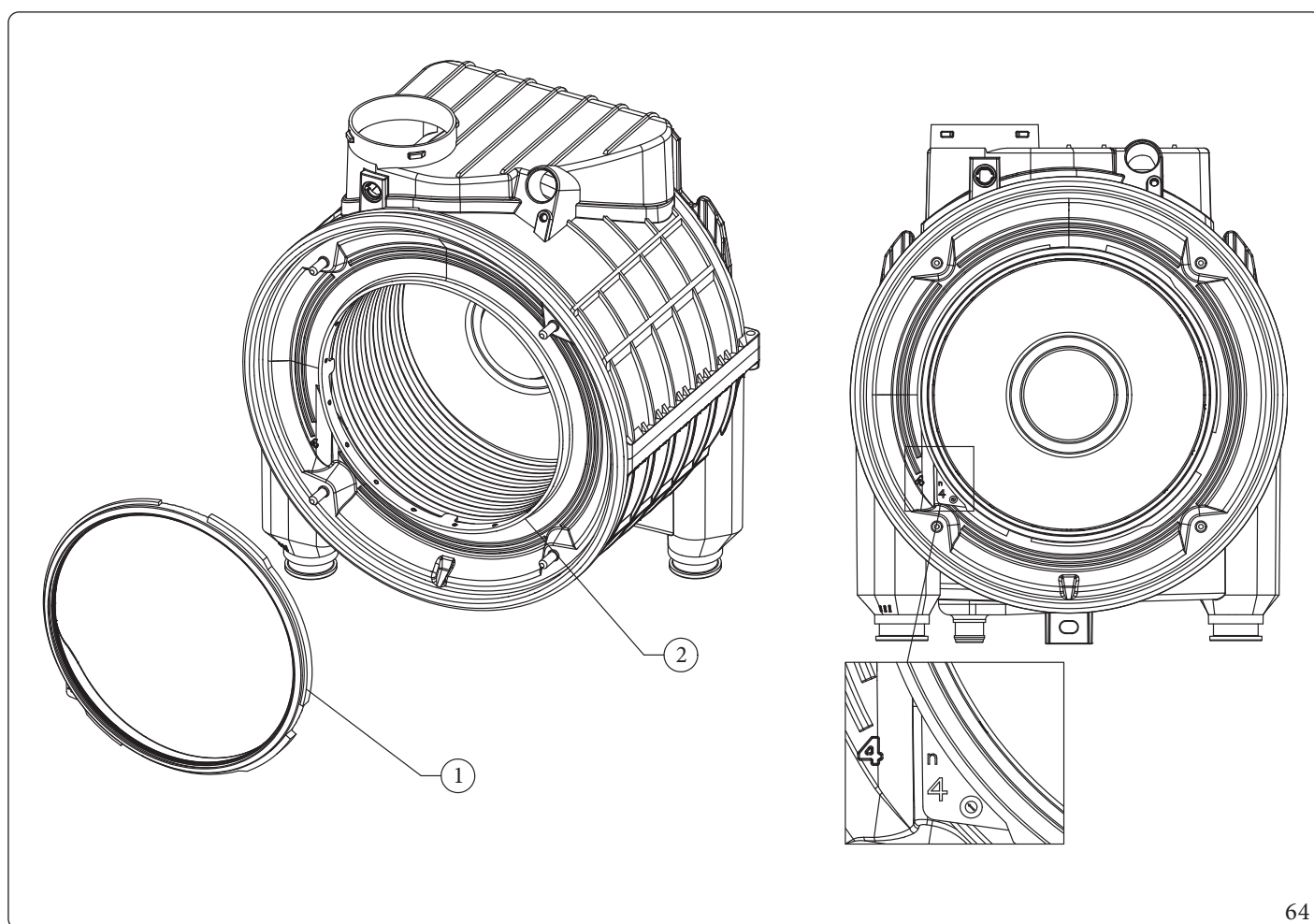

Victrix Tera V238 EU

1. Remove old seals.
2. Install the cord packing (8) by putting the two ends together and pressing them into the housing. Press the gasket back onto the areas identified at '9 o'clock' (A), '12 o'clock' (B) and '3 o'clock' (C) with respect to the ends and then lay the rest of the gasket inside the housing.
3. Install the gasket (9) by aligning it as shown in Fig. 65 and pressing it into the housing.

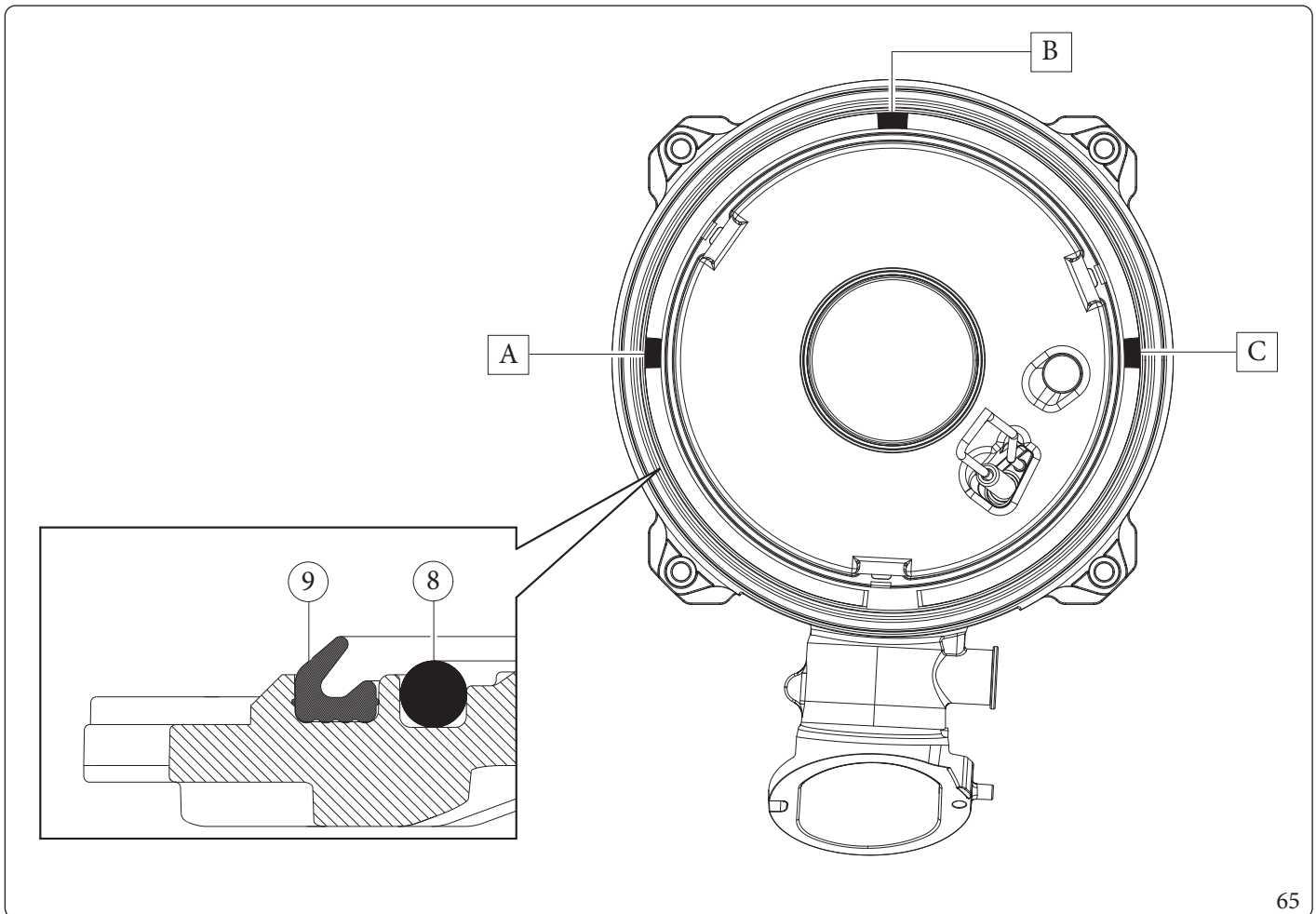

INSTALLER

USER

MAINTENANCE/TECHNICIAN

TECHNICAL DATA

3.25 ASSEMBLING THE MANIFOLD ON THE CONDENSATION MODULE

1. Place the manifold (2, Fig. 66 or Fig. 67) on the module (3, Fig. 66 or Fig. 67).
2. Tighten the 4 nuts (1, Fig. 66 or Fig. 67) on the condensation module (3, Fig. 66 or Fig. 67) in the sequence (A, B, C, D of Fig. 66 or Fig. 67) shown in the drawing.



The tightening torque when assembling the manifold (2) on the condensation module (3) must be 4 Nm.
Do not exceed 5 Nm.

Victrix Tera V228 EU - V232 EU

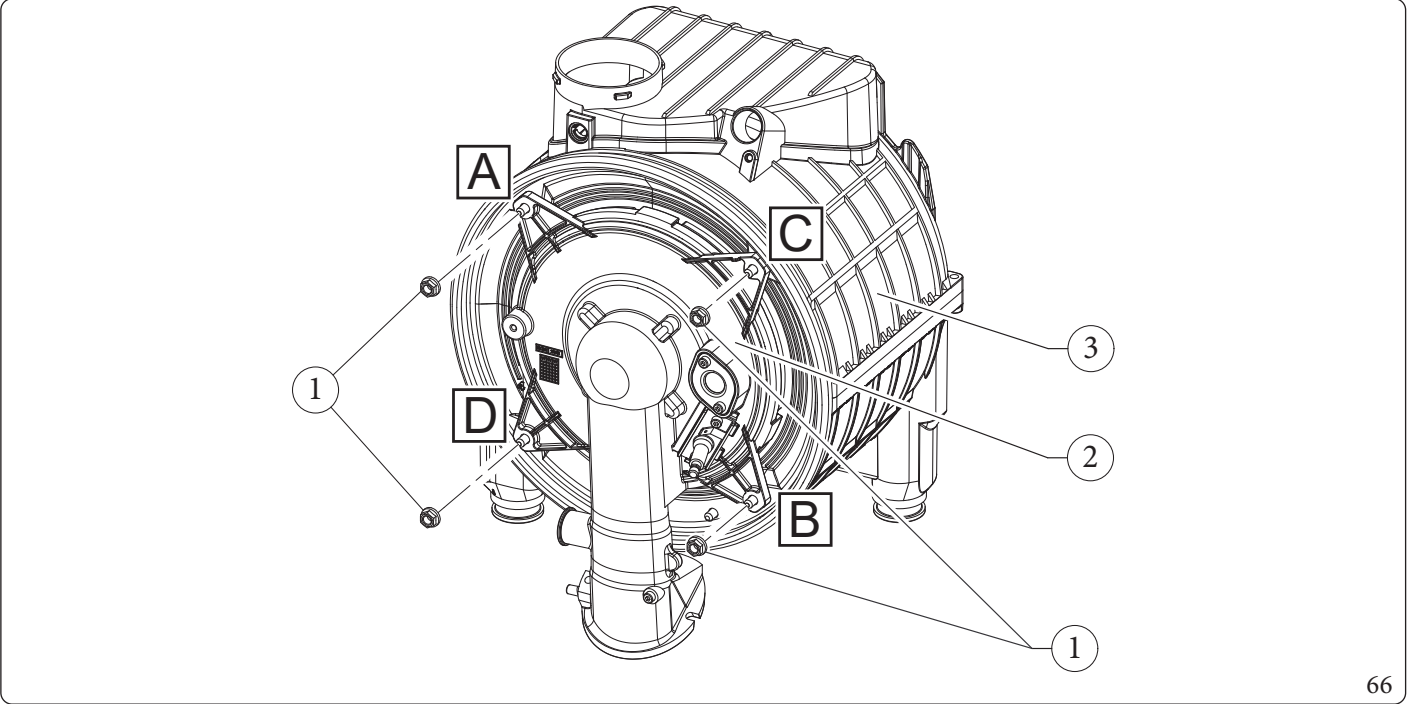

66

Victrix Tera V238 EU

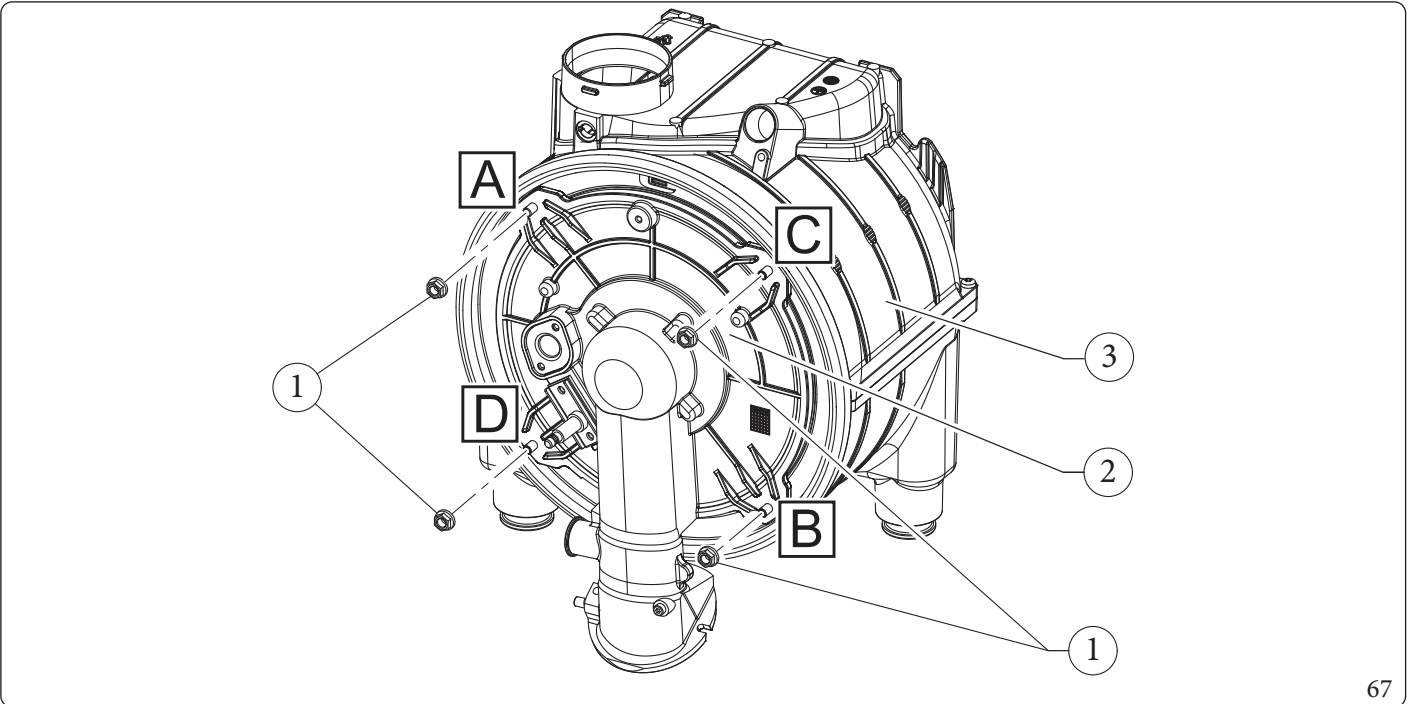

67

4 TECHNICAL DATA

4.1 VARIABLE HEAT OUTPUT



The power data in the table has been obtained with intake-exhaust pipe measuring 0.5 m in length. Gas flow rates refer to net calorific value below a temperature of 15°C and at a pressure of 1013 mbar.

Victrix Tera V2 28 EU

FLOWRATE OUTPUT	HEAT OUTPUT		METHANE (G20)			PROPANE (G31)		
			FANREVS	MODULATION	GASFLOW RATE BURNER	FANREVS	MODULATION	GASFLOW RATE BURNER
(kW)	(kW)		(rpm)	(%)	(m ³ /h)	(rpm)	(%)	(kg/h)
28,7	28,0	D.H.W.	5900	100	3,04	5900	100	2,23
24,5	24,0	HEAT. + D.H.W.	5100	83	2,59	5100	83	1,90
23,5	23,0		4925	79	2,49	4925	79	1,83
22,0	21,5		4625	73	2,33	4625	73	1,71
21,0	20,5		4450	69	2,22	4450	69	1,63
19,5	19,0		4175	63	2,06	4175	63	1,51
18,5	18,1		3975	58	1,96	3975	58	1,44
17,0	16,6		3700	52	1,80	3700	52	1,32
16,0	15,6		3500	48	1,69	3500	48	1,24
14,5	14,1		3225	42	1,53	3225	42	1,13
13,5	13,2		3050	38	1,43	3050	38	1,05
12,0	11,7		2750	31	1,27	2750	31	0,93
11,0	10,7		2575	27	1,16	2575	27	0,85
9,5	9,2		2300	21	1,01	2300	21	0,74
8,5	8,2		2100	17	0,90	2100	17	0,66
7,0	6,8		1825	11	0,74	1825	11	0,54
6,0	5,8		1625	6	0,63	1625	6	0,47
4,5	4,3		1350	0	0,48	1350	0	0,35

INSTALLER

USER

MAINTENANCE TECHNICIAN

TECHNICAL DATA

INSTALLER

USER

MAINTENANCE TECHNICIAN

TECHNICAL DATA

Victrix Tera V2 32 EU

FLOWRATE OUTPUT	HEAT OUTPUT		METHANE (G20)			PROPANE (G31)		
			FANREVS	MODULATION	GASFLOW RATE BURNER	FANREVS	MODULA- TION	GASFLOWRATE BURNER
(kW)	(kW)		(rpm)	(%)	(m ³ /h)	(rpm)	(%)	(kg/h)
32,7	32,0	D.H.W.	6100	100	3,46	6100	100	2,54
28,6	28,0	HEAT. + D.H.W.	5400	86	3,03	5400	86	2,22
27,0	26,4		5125	80	2,86	5125	80	2,10
25,5	24,9		4875	75	2,70	4875	75	1,98
24,0	23,5		4625	69	2,54	4625	69	1,86
22,5	22,0		4375	64	2,38	4375	64	1,75
21,0	20,5		4100	58	2,22	4100	58	1,63
20,0	19,5		3950	55	2,12	3950	55	1,55
18,5	18,1		3700	50	1,96	3700	50	1,44
16,8	16,4		3400	43	1,78	3400	43	1,31
15,5	15,1		3175	38	1,64	3175	38	1,20
14,0	13,6		2925	33	1,48	2925	33	1,09
12,5	12,2		2675	27	1,32	2675	27	0,97
11,0	10,7		2425	22	1,16	2425	22	0,85
9,5	9,2		2175	17	1,01	2175	17	0,74
8,0	7,8		1900	11	0,85	1900	11	0,62
6,5	6,3		1650	5	0,69	1650	5	0,50
5,0	4,8	1400	0	0,53	1400	0	0,39	

Victrix Tera V238 EU

			METHANE (G20)			PROPANE (G31)		
FLOWRATE OUTPUT	HEAT OUTPUT		FANREVS	MODULATION	GASFLOW RATE BURNER	FANREVS	MODULA- TION	GASFLOW RATE BURNER
(kW)	(kW)		(rpm)	(%)	(m ³ /h)	(rpm)	(%)	(kg/h)
38,3	37,3	D.H.W.	6000	100	4,05	6000	100	2,98
32,8	32,0	HEAT. + D.H.W.	5300	86	3,47	5300	86	2,55
31,0	30,3		5025	80	3,28	5025	80	2,41
29,5	28,8		4800	75	3,12	4800	75	2,29
28,0	27,3		4575	70	2,96	4575	70	2,18
26,0	25,4		4275	64	2,75	4275	64	2,02
24,5	23,9		4075	59	2,59	4075	59	1,90
23,0	22,5		3850	54	2,43	3850	54	1,79
21,0	20,5		3550	48	2,22	3550	48	1,63
19,6	19,1		3325	43	2,07	3325	43	1,52
18,0	17,6		3100	38	1,90	3100	38	1,40
16,0	15,6		2800	32	1,69	2800	32	1,24
14,5	14,1		2575	27	1,53	2575	27	1,13
13,0	12,6		2350	22	1,38	2350	22	1,01
11,5	11,2		2125	17	1,22	2125	17	0,89
9,5	9,2		1825	10	1,01	1825	10	0,74
8,0	7,8		1600	5	0,85	1600	5	0,62
6,3	6,1		1350	0	0,67	1350	0	0,49

INSTALLER

USER

MAINTENANCE TECHNICIAN

TECHNICAL DATA

4.2 COMBUSTION PARAMETERS

Combustion parameters: measuring conditions of useful efficiency (flow temperature/return temperature= 80/60 °C), ambient temperature reference = 20 °C.

Victrix Tera V2 28 EU

Gas type		G20	G31
Supply pressure	mbar	20	37
Gas nozzle diameter	mm	4,9	3,7
Flue flow rate at D.H.W. nominal heat output	kg/h	46	48
Flue flow rate at heating nominal heat output	kg/h	40	41
Flue flow rate at min heat output	kg/h	8	8
CO ₂ at Nominal Q.	%	9,2 (9,1 ÷ 9,5)	10,2 (10,0 ÷ 10,4)
O ₂ at Nominal Q.	%	4,4 (4,6 ÷ 3,9)	- (- ÷ -)
CO ₂ at Minimum Q.	%	8,5 (8,3 ÷ 8,7)	9,7 (9,5 ÷ 9,9)
O ₂ at Minimum Q.	%	5,7 (6,0 ÷ 5,3)	- (- ÷ -)
CO with 0% O ₂ at Nom./Min. Q.	ppm	160/4	168/5
NO _x with 0% O ₂ at Nom./Min. Q.	mg/kWh	47,0/24,0	39,0/33,0
Flue temperature at nominal output	°C	73	73
Flue temperature at minimum output	°C	58	56

* O₂ values refer to gas 20%H2NG

Intake / exhaust available head F0=0	Intake / exhaust available head F0=1	Intake / exhaust available head F0=2
Pa	Pa	Pa
32	100	163

Victrix Tera V2 32 EU

Gas type		G20	G31
Supply pressure	mbar	20	37
Gas nozzle diameter	mm	5,7	4,2
Flue flow rate at D.H.W. nominal heat output	kg/h	53	54
Flue flow rate at heating nominal heat output	kg/h	46	47
Flue flow rate at min heat output	kg/h	9	9
CO ₂ at Nominal Q.	%	9,2 (9,1 ÷ 9,5)	10,3 (10,1 ÷ 10,5)
O ₂ at Nominal Q.	%	4,4 (4,6 ÷ 3,9)	- (- ÷ -)
CO ₂ at Minimum Q.	%	8,6 (8,3 ÷ 8,7)	9,6 (9,4 ÷ 9,8)
O ₂ at Minimum Q.	%	5,5 (6,0 ÷ 5,3)	- (- ÷ -)
CO with 0% O ₂ at Nom./Min. Q.	ppm	180/4	195/6
NO _x with 0% O ₂ at Nom./Min. Q.	mg/kWh	65,0/28,0	55,0/34,0
Flue temperature at nominal output	°C	79	79
Flue temperature at minimum output	°C	57	56

* O₂ values refer to gas 20%H2NG

Intake / exhaust available head F0=0	Intake / exhaust available head F0=1	Intake / exhaust available head F0=2
Pa	Pa	Pa
42	130	212



If a Hydrogen ready installation is envisaged for H₂ percentages up to 20%, all gas valve calibration operations must refer to the O₂ values in the table above.



In addition to yearly maintenance, one must also check the energy efficiency of the thermal system, with frequency and procedures that comply with the indications of the technical regulations in force.



When adjusting Nominal Q., if the O₂ values are not reached with the gas flow regulator completely open, no further adjustments are required.

Victrix Tera V238 EU

Gas type		G20	G31
Supply pressure	mbar	20	37
Gas nozzle diameter	mm	6,6	4,9
Flue flow rate at D.H.W. nominal heat output	kg/h	63	64
Flue flow rate at heating nominal heat output	kg/h	54	54
Flue flow rate at min heat output	kg/h	11	11
CO ₂ at Nominal Q.	%	9,0 (8,9 ÷ 9,3)	10,2 (10,1 ÷ 10,4)
O ₂ at Nominal Q.		4,8 (5,0 ÷ 4,2)	- (- ÷ -)
CO ₂ at Minimum Q.	%	8,5 (8,2 ÷ 8,6)	9,6 (9,4 ÷ 9,8)
O ₂ at Minimum Q.		5,7 (6,2 ÷ 5,5)	- (- ÷ -)
CO with 0% O ₂ at Nom./Min. Q.	ppm	190/6	300/8
NO _x with 0% O ₂ at Nom./Min. Q.	mg/kWh	69,0/19,0	-/-
Flue temperature at nominal output	°C	77	77
Flue temperature at minimum output	°C	64	62

* O₂ values refer to gas 20% H₂NG

Intake/exhaust available head F0=0	Intake/exhaust available head F0=1	Intake/exhaust available head F0=2
Pa	Pa	Pa
60	185	301



If a Hydrogen ready installation is envisaged for H₂ percentages up to 20%, all gas valve calibration operations must refer to the O₂ values in the table above.



In addition to yearly maintenance, one must also check the energy efficiency of the thermal system, with frequency and procedures that comply with the indications of the technical regulations in force.



When adjusting Nominal Q., if the O₂ values are not reached with the gas flow regulator completely open, no further adjustments are required.

INSTALLER

USER

MAINTENANCE TECHNICIAN

TECHNICAL DATA

4.3 TECHNICAL DATA TABLE

INSTALLER

USER

MAINTENANCE TECHNICIAN

TECHNICAL DATA

		VICTRIX TERA V228 EU	VICTRIX TERA V232 EU	VICTRIX TERA V238 EU
Domestic hot water nominal heat input	kW	28,7	32,7	38,3
Central heating nominal heat input	kW	24,5	28,6	32,8
Minimum heat input	kW	4,5	5,0	6,3
DHW nominal heat input with 20% H ₂ NG gas	kW	27,1	31,5	35,5
PoCentral heating nominal heat input with 20% H ₂ NG gas	kW	23,2	27,6	31,4
Minimum heat input with 20% H ₂ NG gas	kW	4,3	4,8	6,0
Domestic hot water nominal heat output (useful)	kW	28,0	32,0	37,3
Central heating nominal heat output (useful)	kW	24,0	28,0	32,0
Minimum heat output (useful)	kW	4,3	4,8	6,1
*Effective thermal efficiency 80/60 Nom./Min.	%	97,8/96,6	97,8/96,9	97,7/96,8
*Effective thermal efficiency 50/30 Nom./Min.	%	106,5/107,6	106,3/107,6	104,8/105,6
*Effective thermal efficiency 40/30 Nom./Min.	%	108,0/108,4	107,2/108,6	106,6/107,1
Casing losses with burner On/Off (80-60°C)	W	87,8/24	87,8/28	93,9/32
Chimney losses with burner On/Off (80-60°C)	W	4,6/503,2	4,6/587,4	3,6/705,0
Central heating circuit max. operating pressure	bar	3,0		
Maximum heating temperature	°C	90		
Adjustable central heating temperature (min. operating field)	°C	20		
Adjustable central heating temperature (max operating field)	°C	85		
System expansion vessel total volume	l	5,8	7,3	
Expansion vessel pre-charged pressure	bar	1,0		
Appliance water content	l	3,3	3,4	3,8
Head available with 1000l/h flow rate	kPa	24,4	30,4	31,6
Domestic hot water adjustable temperature	°C	30/60		
Domestic hot water circuit min. pressure (dynamic)	bar	0,3		
Domestic hot water circuit max. operating pressure	bar	10,0		
Flow rate capacity in continuous duty (ΔT 30°C)	l/min	14,1	16,4	18,6
Weight of full boiler	kg	33,7	36,8	40,6
Weight of empty boiler	kg	30,4	33,4	36,8
Electrical connection	V/Hz	230/50		
Nominal power absorption	A	0,7	0,9	1,0
Installed electric power	W	90	120	130
Pump absorbed power	W	-		
Equipment electrical system protection	IP	X5D		
Ambient operating temperature range	°C	-5 ÷ 40		
Ambient operating temperature range with optional antifreeze kit	°C	-15 ÷ 40		
NO _x class	-	6		
*Weighted NO _x G20	mg/kWh	39	34	28
Weighted CO G20	mg/kWh	16	15	17
Weighted NO _x G31	mg/kWh	33	37	31
Weighted CO G31	mg/kWh	16	19	21
Type of appliance	-	B23p B33 B53 B53p B23 C13 C13x C33 C33x C43 C43x C53 C53x C63 C83 C83x C93 C93x		

Market	-	IE
Category	-	II2H3P - I3P

* Efficiencies and weighted NO_x refer to the net calorific value.

The data relevant to domestic hot water performance refer to a dynamic inlet pressure of 2 bar and an inlet temperature of 15°C; the values are measured directly at the appliance outlet considering that to obtain the data declared mixing with cold water is necessary.

4.4 KEY FOR DATA NAMEPLATE

Md.		Cod.Md.	
Sr N°	CHK	PIN	T.
Type			
Qnw/Qn min	Qnw/Qn max	Pn min	Pn max
PMS	PMW	D	TM
NOx Class			
			CONDENSING

68



The technical data are provided on the data plate on the appliance.

	ENG
Md.	Model
Code Md.	Model code
Sr N°	Serial Number
CHK	Check
PIN	PIN code
T.	Minimum and maximum installation temperature
Type	Type of installation (ref. UNI EN 1749)
Qnw min	Minimum DHW heat input
Qn min	Central heating minimum heat input
Qnw max	DHW maximum heat input
Qn max	Central heating maximum heat input
Pn min	Minimum heat output
Pn max	Maximum heat output
PMS	Maximum system pressure
PMW	Maximum domestic hot water pressure
D	Specific flow rate
TM	Maximum operating temperature
NOx Class	NOx Class
CONDENSING	Condensing boiler

INSTALLER

USER

MAINTENANCE TECHNICIAN

TECHNICAL DATA

4.5 TECHNICAL PARAMETERS FOR COMBINATION BOILERS (IN COMPLIANCE WITH REGULATION 813/2013)

The efficiencies and NO_x values in the following tables refer to the gross calorific value.

Model	VICTRIX TERA V2 28 EU		
Condensing Boiler	SI		
Low temperature boiler	NO		
Boiler type B1	NO		
Co-generation appliance for central heating	SI		
Mixed heating appliance	NO		
Nominal heat output	P_n	24	kW
Seasonal energy efficiency of central heating	η_s	94	%
For central heating only and combination boilers: useful heat output			
At nominal heat output in high temperature mode (*)	P_d	24,0	kW
At 30% of nominal heat output in a low temperature mode (**)	P_l	8,0	kW
For central heating only and combination boilers: useful efficiency			
At nominal heat output in high temperature mode (*)	η_d	87,8	%
At 30% of nominal heat output in a low temperature mode (**)	η_l	98,7	%
Auxiliary electricity consumption			
At full load	el_{max}	0,012	kW
At partial load	el_{min}	0,006	kW
In standby mode	P_{SB}	0,002	kW
Other items			
Heat loss in standby	P_{stby}	0,054	kW
Ignition burner energy consumption	P_{ign}	0,000	kW
Emissions of nitrogen oxides	NO_x	35	-
For mixed central heating appliances			
Stated load profile	XL		
Domestic hot water production efficiency	η_{WH}	87	%
Daily electrical power consumption	Q_{elec}	0,109	kWh
Annual electrical power consumption	AEC	24	kWh
Daily gas consumption	Q_{fuel}	22,540	kWh
Annual gas consumption	AFC	18	GJ
(*) High temperature mode means 60°C on return and 80°C on flow.			
(**) Low temperature mode for condensation Boilers means 30°C, for low temperature boilers 37°C and for other appliances 50°C of return temperature.			

Model	VICTRIX TERA V2 32 EU		
Condensing Boiler	SI		
Low temperature boiler	NO		
Boiler type B1	NO		
Co-generation appliance for central heating	SI		
Mixed heating appliance	NO		
Nominal heat output	P_n	28	kW
Seasonal energy efficiency of central heating	η_s	94	%
For central heating only and combination boilers: useful heat output			
At nominal heat output in high temperature mode (*)	P_4	28,0	kW
At 30% of nominal heat output in a low temperature mode (**)	P_1	9,4	kW
For central heating only and combination boilers: useful efficiency			
At nominal heat output in high temperature mode (*)	η_4	87,9	%
At 30% of nominal heat output in a low temperature mode (**)	η_1	98,8	%
Auxiliary electricity consumption			
At full load	el_{max}	0,013	kW
At partial load	el_{min}	0,006	kW
In standby mode	P_{SB}	0,002	kW
Other items			
Heat loss in standby	P_{stby}	0,054	kW
Ignition burner energy consumption	P_{ign}	0,000	kW
Emissions of nitrogen oxides	NO_x	31	-
For mixed central heating appliances			
Stated load profile	XL		
Domestic hot water production efficiency	η_{WH}	87	%
Daily electrical power consumption	Q_{elec}	0,120	kWh
Annual electrical power consumption	AEC	26	kWh
Daily gas consumption	Q_{fuel}	22,543	kWh
Annual gas consumption	AFC	18	GJ
(*) High temperature mode means 60°C on return and 80°C on flow.			
(**) Low temperature mode for condensation Boilers means 30°C, for low temperature boilers 37°C and for other appliances 50°C of return temperature.			

INSTALLER

USER

MAINTENANCE TECHNICIAN

TECHNICAL DATA

Model	VICTRIXTERA V238EU		
Condensing Boiler	SI		
Low temperature boiler	NO		
Boiler type B1	NO		
Co-generation appliance for central heating	SI		
Mixed heating appliance	NO		
Nominal heat output	P_n	32	kW
Seasonal energy efficiency of central heating	η_s	94	%
For central heating only and combination boilers: useful heat output			
At nominal heat output in high temperature mode (*)	P_4	32,0	kW
At 30% of nominal heat output in a low temperature mode (**)	P_1	10,7	kW
For central heating only and combination boilers: useful efficiency			
At nominal heat output in high temperature mode (*)	η_4	87,9	%
At 30% of nominal heat output in a low temperature mode (**)	η_1	98,3	%
Auxiliary electricity consumption			
At full load	el_{max}	0,014	kW
At partial load	el_{min}	0,006	kW
In standby mode	P_{SB}	0,002	kW
Other items			
Heat loss in standby	P_{stby}	0,052	kW
Ignition burner energy consumption	P_{ign}	0,000	kW
Emissions of nitrogen oxides	NO_x	25	-
For mixed central heating appliances			
Stated load profile	XL		
Domestic hot water production efficiency	η_{WH}	85	%
Daily electrical power consumption	Q_{elec}	0,125	kWh
Annual electrical power consumption	AEC	28	kWh
Daily gas consumption	Q_{fuel}	22,943	kWh
Annual gas consumption	AFC	18	GJ
(*) High temperature mode means 60°C on return and 80°C on flow.			
(**) Low temperature mode for condensation Boilers means 30°C, for low temperature boilers 37°C and for other appliances 50°C of return temperature.			

4.6 PRODUCT FICHE (IN COMPLIANCE WITH REGULATION 811/2013)

Victrix Tera V2 28 EU

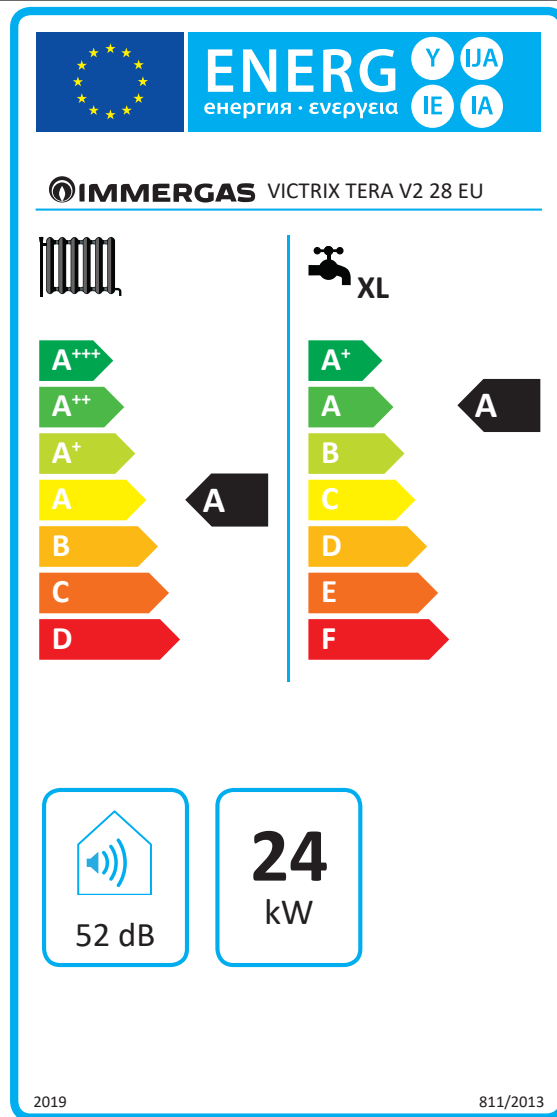

69

Parameter	value
Annual energy consumption for the central heating mode (QHE)	43
Annual electricity consumption for the domestic hot water function (AEC)	24
Annual fuel consumption for the domestic hot water function (AFC)	18
Seasonal space heating energy efficiency (η_s)	94
Water heating energy efficiency (η_{wh})	87

For proper installation of the appliance refer to chapter 1 of this booklet (for the installer) and current installation regulations.
For proper maintenance refer to chapter 3 of this booklet (for the maintenance technician) and adhere to the frequencies and methods set out herein.

INSTALLER

USER

MAINTENANCE TECHNICIAN

TECHNICAL DATA

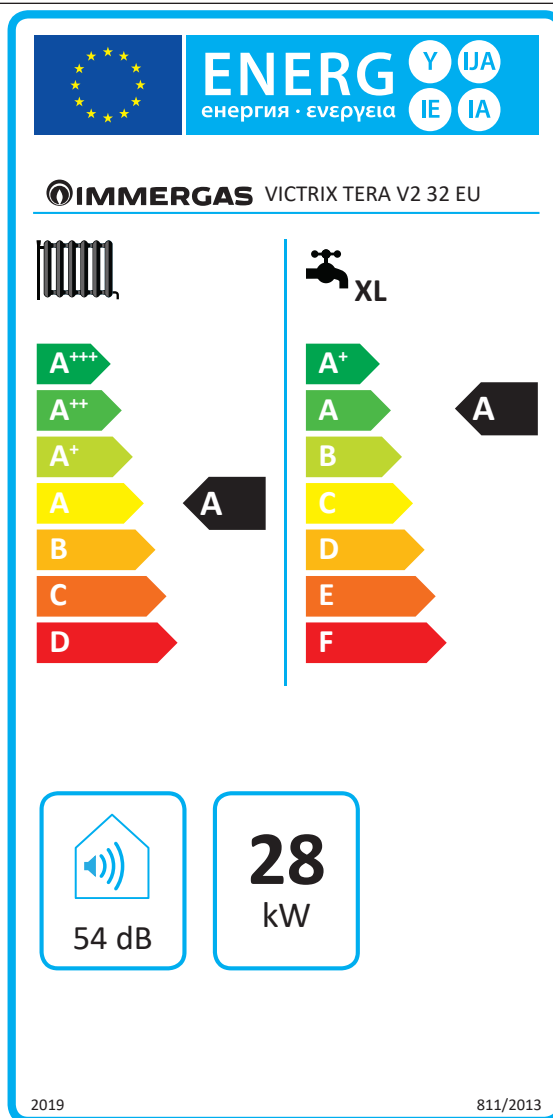

Parameter	value
Annual energy consumption for the central heating mode (QHE)	50
Annual electricity consumption for the domestic hot water function (AEC)	26
Annual fuel consumption for the domestic hot water function (AFC)	18
Seasonal space heating energy efficiency (η_s)	94
Water heating energy efficiency (η_{wh})	87

For proper installation of the appliance refer to chapter 1 of this booklet (for the installer) and current installation regulations.
For proper maintenance refer to chapter 3 of this booklet (for the maintenance technician) and adhere to the frequencies and methods set out herein.

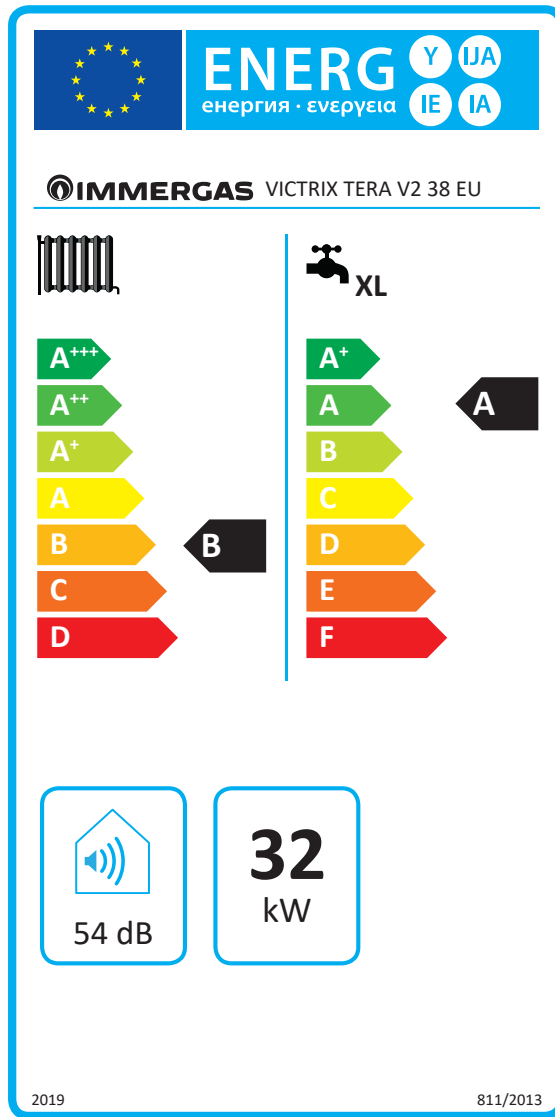

INSTALLER

USER

MAINTENANCE TECHNICIAN

TECHNICAL DATA

71

Parameter	value
Annual energy consumption for the central heating mode (QHE)	59
Annual electricity consumption for the domestic hot water function (AEC)	28
Annual fuel consumption for the domestic hot water function (AFC)	18
Seasonal space heating energy efficiency (η_s)	94
Water heating energy efficiency (η_{wh})	85

For proper installation of the appliance refer to chapter 1 of this booklet (for the installer) and current installation regulations.
For proper maintenance refer to chapter 3 of this booklet (for the maintenance technician) and adhere to the frequencies and methods set out herein.

4.7 PARAMETERS FOR FILLING IN THE PACKAGE FICHE

If an assembly is to be made from this device, use the assembly sheets shown in (Fig. 73 and 75).

For the correct compilation, insert into the appropriate spaces (as shown in the facsimile package fiche (Fig. 72 and 74) the values set out in the tables "Parameters for compiling package fiche" and "Parameters for compiling DHW pack package fiche".

The remaining values must be obtained from the technical data sheets of the products used to make up the assembly (e.g. solar devices, integration heat pumps, temperature controllers).

Use sheet (Fig. 73) for "assemblies" related to the heating function (e.g.: boiler + temperature controller).

Use board (Fig. 75) for "assemblies" related to the domestic hot water function (e.g.: boiler + solar thermal system).

Facsimile for filling in the package fiche for room central heating systems.

Seasonal central heating energy efficiency of the boiler	<div style="border: 1px solid black; padding: 2px; display: inline-block;">1</div> <div style="border: 1px solid black; width: 30px; height: 20px; display: inline-block; vertical-align: middle;"></div> %																														
Temperature control From temperature control board	<div style="border: 1px solid black; padding: 2px; display: inline-block; width: 250px;"> Class I = 1 %, Class II = 2 %, Class III = 1.5 %, Class IV = 2 %, Class V = 3 %, Class VI = 4 %, Class VII = 3.5 %, Class VIII = 5 % </div> <div style="border: 1px solid black; width: 30px; height: 20px; display: inline-block; vertical-align: middle;"></div> %																														
Supplementary boiler From boiler board	<div style="border: 1px solid black; padding: 2px; display: inline-block; width: 200px;"> Seasonal central heating energy efficiency of the room (%) </div> $(\text{ } - 'I') \times 0.1 = \pm \text{ } \% $ <div style="border: 1px solid black; width: 30px; height: 20px; display: inline-block; vertical-align: middle;"></div> %																														
Solar contribution From the board of the solar device	<div style="border: 1px solid black; padding: 2px; display: inline-block; width: 150px;"> Dimensions of the manifold (in m²) </div> <div style="border: 1px solid black; padding: 2px; display: inline-block; width: 100px;"> Volume of the tank (in m³) </div> <div style="border: 1px solid black; padding: 2px; display: inline-block; width: 100px;"> Efficiency of the manifold (in %) </div> <div style="border: 1px solid black; padding: 2px; display: inline-block; width: 150px;"> Classification of the tank A* = 0.95, A = 0.91, B = 0.86, C = 0.83, D-G = 0.81 </div> $('III' \times \text{ } + 'IV' \times \text{ }) \times (0.9 \times (\text{ } / 100) \times \text{ } = + \text{ } \% $ <div style="border: 1px solid black; width: 30px; height: 20px; display: inline-block; vertical-align: middle;"></div> %																														
Supplementary heat pump From the heat pump board	<div style="border: 1px solid black; padding: 2px; display: inline-block; width: 200px;"> Seasonal central heating energy efficiency of the room (%) </div> $(\text{ } - 'I') \times 'II' = + \text{ } \% $ <div style="border: 1px solid black; width: 30px; height: 20px; display: inline-block; vertical-align: middle;"></div> %																														
Solar contribution and supplementary heat pump Select the lowest value	$0.5 \times \text{ } \text{ O } 0.5 \times \text{ } = - \text{ } \% $ <div style="border: 1px solid black; width: 30px; height: 20px; display: inline-block; vertical-align: middle;"></div> %																														
Seasonal central heating energy efficiency of the set	<div style="border: 1px solid black; width: 30px; height: 20px; display: inline-block;"></div> %																														
Seasonal central heating energy efficiency class of the set	<div style="border: 1px solid black; padding: 5px; display: inline-block;"> <table style="text-align: center; border-collapse: collapse;"> <tr> <td style="border: 1px solid black; width: 20px; height: 20px;"></td> <td style="border: 1px solid black; width: 20px; height: 20px;"></td> <td style="border: 1px solid black; width: 20px; height: 20px;"></td> <td style="border: 1px solid black; width: 20px; height: 20px;"></td> <td style="border: 1px solid black; width: 20px; height: 20px;"></td> <td style="border: 1px solid black; width: 20px; height: 20px;"></td> <td style="border: 1px solid black; width: 20px; height: 20px;"></td> <td style="border: 1px solid black; width: 20px; height: 20px;"></td> <td style="border: 1px solid black; width: 20px; height: 20px;"></td> <td style="border: 1px solid black; width: 20px; height: 20px;"></td> </tr> <tr> <td style="font-weight: bold; font-size: 1.2em;">G</td> <td style="font-weight: bold; font-size: 1.2em;">F</td> <td style="font-weight: bold; font-size: 1.2em;">E</td> <td style="font-weight: bold; font-size: 1.2em;">D</td> <td style="font-weight: bold; font-size: 1.2em;">C</td> <td style="font-weight: bold; font-size: 1.2em;">B</td> <td style="font-weight: bold; font-size: 1.2em;">A</td> <td style="font-weight: bold; font-size: 1.2em;">A⁺</td> <td style="font-weight: bold; font-size: 1.2em;">A⁺⁺</td> <td style="font-weight: bold; font-size: 1.2em;">A⁺⁺⁺</td> </tr> <tr> <td style="font-size: 0.8em;">< 30 %</td> <td style="font-size: 0.8em;">≥ 30 %</td> <td style="font-size: 0.8em;">≥ 34 %</td> <td style="font-size: 0.8em;">≥ 36 %</td> <td style="font-size: 0.8em;">≥ 75 %</td> <td style="font-size: 0.8em;">≥ 82 %</td> <td style="font-size: 0.8em;">≥ 90 %</td> <td style="font-size: 0.8em;">≥ 98 %</td> <td style="font-size: 0.8em;">≥ 125 %</td> <td style="font-size: 0.8em;">≥ 150 %</td> </tr> </table> </div>											G	F	E	D	C	B	A	A ⁺	A ⁺⁺	A ⁺⁺⁺	< 30 %	≥ 30 %	≥ 34 %	≥ 36 %	≥ 75 %	≥ 82 %	≥ 90 %	≥ 98 %	≥ 125 %	≥ 150 %
G	F	E	D	C	B	A	A ⁺	A ⁺⁺	A ⁺⁺⁺																						
< 30 %	≥ 30 %	≥ 34 %	≥ 36 %	≥ 75 %	≥ 82 %	≥ 90 %	≥ 98 %	≥ 125 %	≥ 150 %																						
Boiler and supplementary heat pump installed with low temperature heat emitters at 35 °C? From the board of the heat pump	$\text{ } + (50 \times 'II') = \text{ } \% $ <div style="border: 1px solid black; width: 30px; height: 20px; display: inline-block; vertical-align: middle;"></div> %																														
<p><i>The energy efficiency of the set of products indicated in this sheet may not reflect the actual energy efficiency after installation since such efficiency is affected by additional factors, such as the heat loss in the distribution system and the size of the products compared to the size and features of the building.</i></p>																															

Parameters for filling in the assembly chart

Parameter	VICTRIX TERA V228 EU	VICTRIX TERA V232 EU	VICTRIX TERA V238 EU
"I"		94	
"II"		*	
"III"	1,11	0,95	0,84
"IV"	0,44	0,37	0,33

* to be established by means of table 5 of Regulation 811/2013 in case of "assembly" including a heat pump to integrate the boiler. In this case the boiler must be considered as the main appliance of the assembly.

Room central heating system package fiche.

Seasonal central heating energy efficiency of the boiler 1 %

Temperature control
From temperature control board

Class I = 1 %, Class II = 2 %,
 Class III = 1.5 %, Class IV = 2 %,
 Class V = 3 %, Class VI = 4 %,
 Class VII = 3.5 %, Class VIII = 5 %

2 %

Supplementary boiler
From boiler board

Seasonal central heating energy efficiency of the room (%)

(- _____) x 0.1 = ± 3 %

Solar contribution
From the board of the solar device

Dimensions of the manifold (in m²)

Volume of the tank (in m³)

Efficiency of the manifold (in %)

Classification of the tank
 A* = 0.95, A = 0.91,
 B = 0.86, C = 0.83,
 D-G = 0.81

(_____ x + _____ x) x (0.9 x (/ 100) x = + 4 %

Supplementary heat pump
From the heat pump board

Seasonal central heating energy efficiency (in %)

(- _____) x _____ = + 5 %

Solar contribution and supplementary heat pump

Select the lowest value

0.5 x 4 0 0.5 x 5 = - 6 %

Seasonal central heating energy efficiency of the set 7 %

Seasonal central heating energy efficiency class of the set

<input type="checkbox"/>	<input type="checkbox"/>	<input type="checkbox"/>	<input type="checkbox"/>	<input type="checkbox"/>	<input type="checkbox"/>	<input type="checkbox"/>	<input type="checkbox"/>	<input type="checkbox"/>	<input type="checkbox"/>
G	F	E	D	C	B	A	A⁺	A⁺⁺	A⁺⁺⁺
< 30 %	≥ 30 %	≥ 34 %	≥ 36 %	≥ 75 %	≥ 82 %	≥ 90 %	≥ 98 %	≥ 125 %	≥ 150 %

Boiler and supplementary heat pump installed with low temperature heat emitters at 35 °C?

From the board of the heat pump 7 + (50 x _____) = %

The energy efficiency of the set of products indicated in this sheet may not reflect the actual energy efficiency after installation since such efficiency is affected by additional factors, such as the heat loss in the distribution system and the size of the products compared to the size and features of the building.

INSTALLER

USER

MAINTENANCE TECHNICIAN

TECHNICAL DATA

Facsimile for filling in the domestic hot water production system package fiche

Water heating energy efficiency of combination boiler

1
'I' %

Stated load profile:

Solar contribution

From the board of the solar device

Auxiliary electricity

↓

$$(1.1 \times 'I' - 10 \%) \times 'II' - \text{Auxiliary electricity} - 'I' = + \text{2} \%$$

Water heating energy efficiency of the assembly in average climate conditions

3
 %

Water heating energy efficiency class of the assembly in average climate conditions

<input type="checkbox"/>	<input type="checkbox"/>	<input type="checkbox"/>	<input type="checkbox"/>	<input type="checkbox"/>	<input type="checkbox"/>	<input type="checkbox"/>	<input type="checkbox"/>	<input type="checkbox"/>	<input type="checkbox"/>										
G	F	E	D	C	B	A	A⁺	A⁺⁺	A⁺⁺⁺										
<input type="checkbox"/> M	<table style="width: 100%; border-collapse: collapse;"> <tr> <td style="width: 10%; text-align: right;">< 27 %</td> <td style="width: 10%; text-align: left;">≥ 27 %</td> <td style="width: 10%; text-align: right;">≥ 30 %</td> <td style="width: 10%; text-align: left;">≥ 33 %</td> <td style="width: 10%; text-align: right;">≥ 36 %</td> <td style="width: 10%; text-align: left;">≥ 39 %</td> <td style="width: 10%; text-align: right;">≥ 65 %</td> <td style="width: 10%; text-align: left;">≥ 100 %</td> <td style="width: 10%; text-align: right;">≥ 130 %</td> <td style="width: 10%; text-align: left;">≥ 163 %</td> </tr> </table>									< 27 %	≥ 27 %	≥ 30 %	≥ 33 %	≥ 36 %	≥ 39 %	≥ 65 %	≥ 100 %	≥ 130 %	≥ 163 %
< 27 %	≥ 27 %	≥ 30 %	≥ 33 %	≥ 36 %	≥ 39 %	≥ 65 %	≥ 100 %	≥ 130 %	≥ 163 %										
<input type="checkbox"/> L	<table style="width: 100%; border-collapse: collapse;"> <tr> <td style="width: 10%; text-align: right;">< 27 %</td> <td style="width: 10%; text-align: left;">≥ 27 %</td> <td style="width: 10%; text-align: right;">≥ 30 %</td> <td style="width: 10%; text-align: left;">≥ 34 %</td> <td style="width: 10%; text-align: right;">≥ 37 %</td> <td style="width: 10%; text-align: left;">≥ 50 %</td> <td style="width: 10%; text-align: right;">≥ 75 %</td> <td style="width: 10%; text-align: left;">≥ 115 %</td> <td style="width: 10%; text-align: right;">≥ 150 %</td> <td style="width: 10%; text-align: left;">≥ 188 %</td> </tr> </table>									< 27 %	≥ 27 %	≥ 30 %	≥ 34 %	≥ 37 %	≥ 50 %	≥ 75 %	≥ 115 %	≥ 150 %	≥ 188 %
< 27 %	≥ 27 %	≥ 30 %	≥ 34 %	≥ 37 %	≥ 50 %	≥ 75 %	≥ 115 %	≥ 150 %	≥ 188 %										
<input type="checkbox"/> XL	<table style="width: 100%; border-collapse: collapse;"> <tr> <td style="width: 10%; text-align: right;">< 27 %</td> <td style="width: 10%; text-align: left;">≥ 27 %</td> <td style="width: 10%; text-align: right;">≥ 30 %</td> <td style="width: 10%; text-align: left;">≥ 35 %</td> <td style="width: 10%; text-align: right;">≥ 38 %</td> <td style="width: 10%; text-align: left;">≥ 55 %</td> <td style="width: 10%; text-align: right;">≥ 80 %</td> <td style="width: 10%; text-align: left;">≥ 123 %</td> <td style="width: 10%; text-align: right;">≥ 160 %</td> <td style="width: 10%; text-align: left;">≥ 200 %</td> </tr> </table>									< 27 %	≥ 27 %	≥ 30 %	≥ 35 %	≥ 38 %	≥ 55 %	≥ 80 %	≥ 123 %	≥ 160 %	≥ 200 %
< 27 %	≥ 27 %	≥ 30 %	≥ 35 %	≥ 38 %	≥ 55 %	≥ 80 %	≥ 123 %	≥ 160 %	≥ 200 %										
<input type="checkbox"/> XXL	<table style="width: 100%; border-collapse: collapse;"> <tr> <td style="width: 10%; text-align: right;">< 28 %</td> <td style="width: 10%; text-align: left;">≥ 28 %</td> <td style="width: 10%; text-align: right;">≥ 32 %</td> <td style="width: 10%; text-align: left;">≥ 36 %</td> <td style="width: 10%; text-align: right;">≥ 40 %</td> <td style="width: 10%; text-align: left;">≥ 60 %</td> <td style="width: 10%; text-align: right;">≥ 85 %</td> <td style="width: 10%; text-align: left;">≥ 131 %</td> <td style="width: 10%; text-align: right;">≥ 170 %</td> <td style="width: 10%; text-align: left;">≥ 213 %</td> </tr> </table>									< 28 %	≥ 28 %	≥ 32 %	≥ 36 %	≥ 40 %	≥ 60 %	≥ 85 %	≥ 131 %	≥ 170 %	≥ 213 %
< 28 %	≥ 28 %	≥ 32 %	≥ 36 %	≥ 40 %	≥ 60 %	≥ 85 %	≥ 131 %	≥ 170 %	≥ 213 %										

Water heating energy efficiency class in colder and hotter climate conditions

Colder: $\text{3} - 0.2 \times \text{2} = \text{ } \%$

Hotter: $\text{3} + 0.4 \times \text{2} = \text{ } \%$

The energy efficiency of the set of products indicated in this sheet may not reflect the actual energy efficiency after installation since such efficiency is affected by additional factors, such as the heat loss in the distribution system and the size of the products compared to the size and features of the building.

Parameters for filling in the DHW package fiche

Parameter	VICTRIX TERA V228 EU	VICTRIX TERA V232 EU	VICTRIX TERA V238 EU
"I"	87		85
"II"			*
"III"			*

* to be determined according to Regulation 811/2013 and transient calculation methods as per Notice of the European Community no. 207/2014.

Domestic hot water production system package fiche.

Water heating energy efficiency of combination boiler

%

Stated load profile:

Solar contribution

From the board of the solar device

Auxiliary electricity

(1.1 x - 10 %) x - - = + %

Water heating energy efficiency of the assembly in average climate conditions

%

Water heating energy efficiency class of the assembly in average climate conditions

	<input type="checkbox"/>	<input type="checkbox"/>	<input type="checkbox"/>	<input type="checkbox"/>	<input type="checkbox"/>	<input type="checkbox"/>	<input type="checkbox"/>	<input type="checkbox"/>	<input type="checkbox"/>	<input type="checkbox"/>
	G	F	E	D	C	B	A	A ⁺	A ⁺⁺	A ⁺⁺⁺
<input type="checkbox"/> M	< 27 %	≥ 27 %	≥ 30 %	≥ 33 %	≥ 36 %	≥ 39 %	≥ 65 %	≥ 100 %	≥ 130 %	≥ 163 %
<input type="checkbox"/> L	< 27 %	≥ 27 %	≥ 30 %	≥ 34 %	≥ 37 %	≥ 50 %	≥ 75 %	≥ 115 %	≥ 150 %	≥ 188 %
<input type="checkbox"/> XL	< 27 %	≥ 27 %	≥ 30 %	≥ 35 %	≥ 38 %	≥ 55 %	≥ 80 %	≥ 123 %	≥ 160 %	≥ 200 %
<input type="checkbox"/> XXL	< 28 %	≥ 28 %	≥ 32 %	≥ 36 %	≥ 40 %	≥ 60 %	≥ 85 %	≥ 131 %	≥ 170 %	≥ 213 %

Water heating energy efficiency class in colder and hotter climate conditions

Colder: - 0.2 x = %

Hotter: + 0.4 x = %

The energy efficiency of the set of products indicated in this sheet may not reflect the actual energy efficiency after installation since such efficiency is affected by additional factors, such as the heat loss in the distribution system and the size of the products compared to the size and features of the building.

INSTALLER

USER

MAINTENANCE TECHNICIAN

TECHNICAL DATA



This instruction booklet is made of ecological paper.

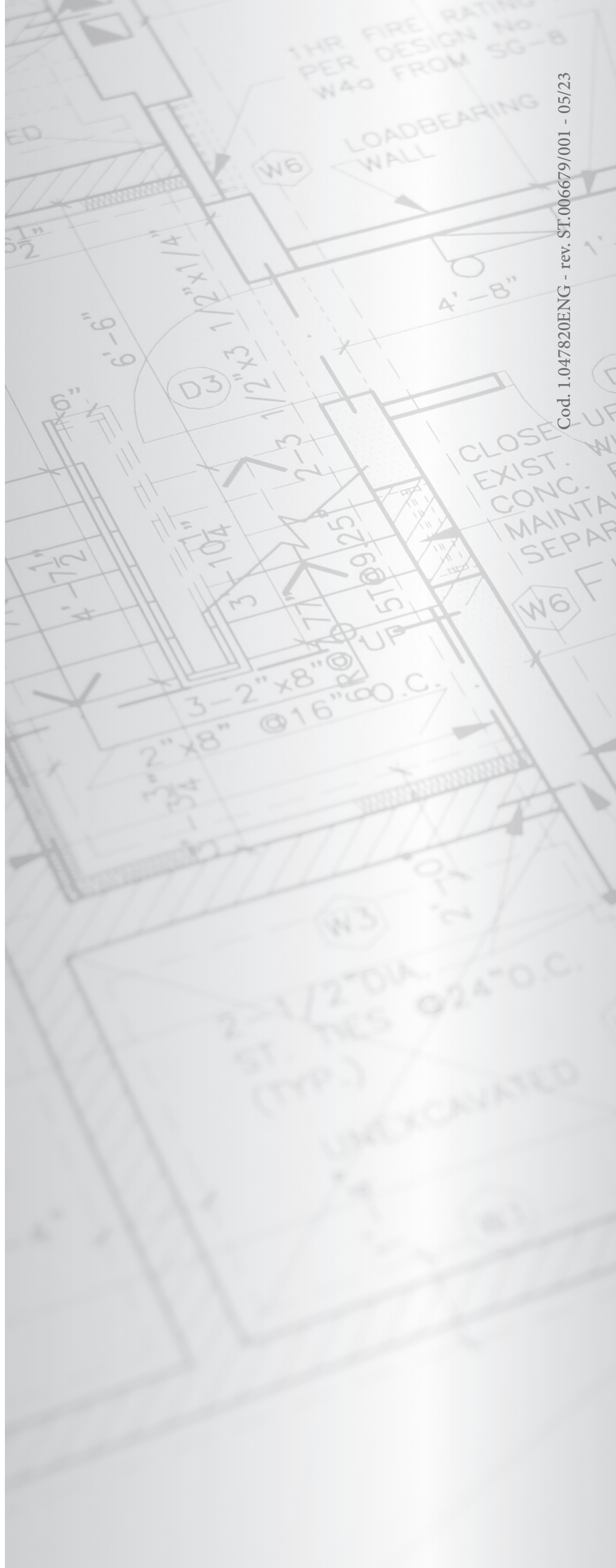

Cod. 1.047820ENG - rev. ST.006679/001 - 05/23

immergas.com

Immergas S.p.A.
42041 Brescello (RE) - Italy
Tel. 0522.689011
Fax 0522.680617



IMMERGAS
IMMERGAS SPA - ITALY
CERTIFIED COMPANY
UNI EN ISO 9001:2015

Design, manufacture and post-sale assistance of gas boilers, gas water heaters and related accessories